

SIRCHIE[®]

FINGER PRINT LABORATORIES, INC.

INTRODUCTION

**TABLE OF
CONTENTS**

**ORDERING
INFORMATION**

**ORDER
FORM**

**PRODUCT
INDEX**

CRIMINAL INVESTIGATION EQUIPMENT

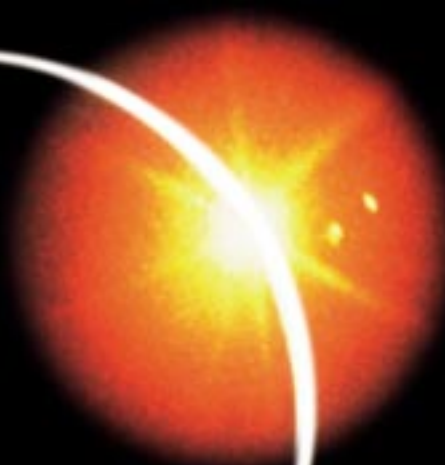

ORDERING INSTRUCTIONS

All business correspondence and orders should be addressed to:

SIRCHIE® Finger Print Laboratories, Inc.

100 Hunter Place

Youngsville, North Carolina 27596 USA

ORDER BY PHONE:

TOLL FREE: (800) 356-7311

INTERNATIONAL: (919) 554-2244

ORDER BY FAX:

TOLL FREE: (800) 899-8181

INTERNATIONAL: (919) 554-2266

WEBSITE: <http://www.sirchie.com>

E-MAIL ADDRESS: sirchie@mindspring.com

TERMS AND CONDITIONS OF SALE

All prices are F.O.B. Youngsville, North Carolina, U.S.A., or **SIRCHIE®**'s shipping point. All orders are subject to acceptance by **SIRCHIE®**. All prices are subject to change without notice.

OPEN BILLING is extended to U.S. federal, state and local governmental agencies in good standing. Orders must be accompanied by a purchase order number or a voucher. Handling and shipping charges are charged and added to the invoice amount. Terms of payment are net 30 days. In case of late payment, a 1.5% interest charge is added to the unpaid principal.

PREPAYMENT in U.S. funds is required on all orders placed by individuals or companies who do not have pre-approved credit lines. The pre-payment must include shipping and handling charges or written authorization to forward materials, handling charges and shipping charges collect.

FOREIGN ORDERS require pre-payment or an irrevocable letter of credit advised and confirmed by a major U.S. bank payable in U.S. dollars at sight upon standard proof of shipment. All banking charges including those of negotiating and paying banks, documentation, legalization and/or authentication charges are to be paid by the purchaser.

VISA, MASTERCARD and AMERICAN EXPRESS orders are accepted.



MINIMUM ORDER. Domestic minimum order is \$25.00, excluding shipping and handling. International minimum order is \$500.00, excluding shipping, handling and banking charges.

HANDLING CHARGE. An additional charge of \$5.00 will apply to all orders.

SALES TAX. Any order, not exempt, to be shipped to destinations within New Jersey or North Carolina will be charged state sales tax. Exempt organizations must provide resale or tax exempt certificates.

SHIPMENTS to destinations in the United States are made F.O.B. Youngsville, North Carolina or **SIRCHIE®**'s shipping point via UPS, RPS or U.S. Parcel Post Service according to the prevailing rates. The following table is for reference only:

1-10 lbs. \$12.50	30-50 lbs. \$27.00
11-29 lbs. \$22.00	50-70 lbs. \$35.00

If directed by the purchaser, shipments will be made by other carriers, including air freight or expressed delivery, at the additional prevailing rates.

RETURNS AND EXCHANGES will not be accepted unless authorized by **SIRCHIE®** in advance. Products returned unused and within seven days of authorization will be subject to a restocking charge of 20% of the original invoice price. Special ordered or non-inventoried products are not returnable under any conditions. Shipping and handling charges on returned goods will be pre-paid.

EXPORT LICENSES. Certain products may not be exported from the United States without specific approval by the U.S. Department of Commerce and or/the U.S. Department of State. Unless agreed by in advance, it is the buyer's responsibility, not **SIRCHIE®**'s, to obtain such license. **SIRCHIE®** reserves the right to refuse shipment to any exporter who has not satisfactorily shown compliance with applicable export regulations.

Prices, charges, illustrations, specifications and descriptions are subject to change without notice at the discretion of the manufacturer, SIRCHIE Finger Print Laboratories, Inc., its subsidiaries or its subcontractors. All rights reserved. Reproduction or use, without express permission, of written or pictorial content in any manner is prohibited. While every precaution has been taken in the preparation of this manual, the manufacturer and publisher assume no responsibility for errors or omissions. Copyright © 2000 Sirchie® Finger Print Laboratories, Inc.

Price: \$125.00

See Section 15 (page 308) for the latest technological advancements.

about **SIRCHIE**® ...

For more than 50 years **SIRCHIE**® Finger Print Laboratories, Inc., and its subsidiary companies, Law Enforcement Associates Inc., American Institute of Applied Sciences Inc., Premier Crown® Corp., and Search Productions (collectively known as the **SIRCHIE**® group) have been innovators in the design and development of specialized products for the worldwide law enforcement community. The **SIRCHIE**® group has an established international reputation based on a tradition of supplying quality products to a demanding market.

GREAT EXPECTATIONS—Naturally, from a manufacturer who, for more than half a century, has been a symbol of craftsmanship and innovation in the design and production of equipment for criminal investigation.

GREAT REALIZATIONS—Why not, from a company with years of know-how put to use in this age of advanced state-of-the-art technology. It's obvious that **SIRCHIE**® Finger Print Laboratories will continue to lead the industry with the publication of this catalog—a graphic representation of just what's been accomplished over the last few years.

Not merely more pages than the previous catalog, this publication offers the skilled professional the most complete, up-to-date products so vitally necessary during these times—everything from a jar of latent fingerprint powder to fully equipped mobile laboratories; from criminal record cards to computer software systems. **SIRCHIE**® provides the tools to fight crime.



*Sirchie Finger Print Laboratories Corporate Offices and Manufacturing Facilities
Youngsville, North Carolina*

Table of Contents

I.	FINGERPRINT TAKING AND RECORDING PRODUCTS	3-49
II.	LATENT PRINT DEVELOPMENT AND LIFTING PRODUCTS	50-118
III.	BLUEMAXX™ PORTABLE ILLUMINATION PRODUCTS	119-129
IV.	OPTICAL ENHANCEMENT AND FINGERPRINT CLASSIFICATION	130-142
V.	FORENSIC AND IDENTIFICATION PHOTOGRAPHY	143-175
VI.	EVIDENCE COLLECTION AND PROCESSING	176-211
VII.	IMPRESSION EVIDENCE	212-222
VIII.	FORENSIC EVIDENCE COLLECTION KITS	223-231
IX.	ULTRAVIOLET FORENSIC LIGHTS	232-242
X.	VISIBLE AND FLUORESCENT INVISIBLE DETECTION MATERIALS	243-255
XI.	FORENSIC EVIDENCE EQUIPMENT	256-272
XI-A.	FORENSIC CONTAINMENT PRODUCTS	273-281
XII.	WEAPONS AND METAL DETECTION PRODUCTS	282-283B
XIII.	COMPUTER SOFTWARE SYSTEMS	284-289
XIV.	SPECIAL PURPOSE POLICE VEHICLES AND EQUIPMENT	290-307
XV.	NEW TECHNOLOGY, PRODUCTS	308-337

FINGERPRINT RECORDING PRODUCTS

Fingerprinting is an important process and a primary method for identifying individuals. With the proper fingerprint records, positive identification may be achieved.

It is important that quality materials be used during the fingerprint taking process in order to obtain the most reliable results.

SIRCHIE® has set the standard for high-quality fingerprint recording products for more than 50 years.

There are presently three methods of fingerprint taking. Each method utilizes one of the following elements: a pad, an ink slab and roller, or the **PRINT-MATIC**™ pre-inked Porelon® roller. **SIRCHIE**® offers these products as well as a full line of equipment and supplies to complement each fingerprint taking method.

These supplies include high-quality fingerprint inks, ink cleaning supplies, equipment for postmortem fingerprinting, fingerprint record cards and educational tools.

At **SIRCHIE**®, customer satisfaction is of paramount importance. That's why **SIRCHIE**® is constantly striving to provide only the highest-quality products to its customers, and is dedicated to meeting the varying requirements of the many different law enforcement agencies and identification departments around the United States and the world.

SECTION I TABLE OF CONTENTS

Fingerprint Taking and Recording Products

Autopalm® Outfits	30-35
Cardholders	16-17
Compact Fingerprint Kits	36-37
Disposable Inked Strips	12
Educational Tools, Fingerprint	49B
Elimination & Field Kits	38-39
EZID Ceramic Fingerprint Pads	49A
File Cabinets, Record Card	47-48
Fingerprint Ink	13
Fingerprint Combinations	18-19
Fingerprint Outfits	23-26
Guide Cards	49
Hand Cleaners	20-22
Ink Rollers	14-15
Ink Slabs	15
Lansberry's Ridge Builder	13
Pedestal Fingerprint Units	27-29
Porelon® Pads	6-7
Postmortem Tools & Kits	40-44
PRINTMATIC™ Rollers	8-12
Printover™ Tabs	47
Record Cards	45-47
Slab and Roller Cleaners	20-22
Wall Charts, Fingerprint	49A
Videos, Fingerprint Taking	49A

RECORDING FINGERPRINTS

Quality materials must be used during the fingerprint taking process in order to obtain the most desirable results. **SIRCHIE®** has set the standard in high-quality fingerprint equipment for over 50 years.



Fig 1: The operator rolls ink onto the slab with the **PRINTMATIC™** pre-inked Porelon roller



Fig 2: The subject is positioned so that his forearm is parallel to the floor.



Fig 3: Next, the operator rolls the subject's finger on the ink slab.

Three methods:

Ink Slab and Roller, Porelon® and **PRINTMATIC™**

There are now three methods for recording fingerprints—with a Porelon® Pad; with an Ink Slab and Roller; and with the **PRINTMATIC™** pre-inked Porelon® roller. There are advantages to all three methods, and the choice between them is one based primarily on application.

The Porelon® Pad method requires no advance preparation because the pad contains a built-in ink supply. The main advantage of the Porelon® Pad method is that it requires less skill to obtain satisfactory prints. The Ink Slab and Roller method requires more skill than the Porelon® pad method, but the prints obtained tend to be cleaner and of sharper contrast. That makes them ideally suited for computer enhancement and database storage.

The third and newest method is an outstanding **SIRCHIE®** innovation called **PRINTMATIC™**. This method combines the advantages of the slab and roller method with the Porelon® pad method. The **PRINTMATIC™** is a pre-inked roller that allows the operator to apply a thin, uniform layer of ink to the inking slab (Fig.1).

Work Table Height

For best results, the inking area and cardholder should be approximately 39 inches from the floor. This height allows the forearm of a subject of average height to be parallel to the floor, at which position it is best to roll and record fingerprints. **SIRCHIE®** offers several fingerprint taking stations that are either pedestal-mounted at the required height or of desktop design that, when placed on the average table top, will achieve the height required.

Preparing the Ink Slab (Slab and Roller Method):

Step 1) First, ink the roller. Apply a small amount (about a 1/4" stream) of fingerprint ink on the right side of the slab, toward the back. Roll a two- to three-inch-wide layer of ink on the back portion of the slab—lifting the roller off the slab after each stroke and returning to the starting point (do not use a back-and-forth motion with the roller). Repeat several times until a thin film of ink forms on the roller.

Step 2) Next, using the same roller motion (without rolling back and forth), spread the layer toward the front edge of the slab, until a smooth, uniform coating of ink forms. The front edge is where the fingerprints are rolled. When the ink on the front edge becomes too thin, replenish the ink roller on the back edge of the slab and repeat step two.

Porelon® Pad Method

As stated earlier, no advance preparation is needed to use the Porelon® pad. However, the pad surface should be cleaned occasionally to remove oil and dirt deposits by wiping the surface lightly with a soft, dry, lint-free cloth.

PRINTMATIC™ Method

Like the Slab and Roller method, the **PRINTMATIC™** method requires that the operator roll ink onto an inking slab. The difference is that with the **PRINTMATIC™** pre inked roller, coating the slab requires only a few passes of the roller in the same direction to apply a thin, even layer of ink (Fig. 1).

FINGERPRINT TAKING PROCEDURES AND METHODS

Inking and Rolling the Fingers

The following recommended procedure is as practiced by the FBI and is applicable for all three methods listed left.

To avoid possible smearing, always begin the fingerprint taking procedure by inking and rolling the fingers on the right hand.

It is recommended that each finger be inked and rolled individually (i.e., ink the thumb then roll it immediately, ink the forefinger, then immediately roll it, etc.). If all the fingers are first inked and then rolled, there is the chance some ink may be transferred from a finger as it is curled out of the way prior to rolling, thus causing that finger to print lightly when rolled.

After the fingerprints on right hand are recorded, ink and roll the fingers on the left hand. When that is accomplished, record the plain impressions of both hands. An examination of the fingerprint record card reveals that these steps follow the order of the space allotted for each set of impressions.

■ **1)** The subject stands to the right and rear of the operator (Fig. 2). The operator grips the subject's right hand with his right hand, cupping his fingers over the subject's fingers and tucking under those fingers not being inked.

The operator uses his left hand to guide the finger being inked (Fig. 3).

Fingers are rolled on the ink slab away from the subject's body. They are inked from nail edge to nail edge from the top of the finger to the first joint. Fingers are rolled only once to ensure the right amount of ink is applied.

■ **2)** After the fingers on the right hand are inked, the operator inks and rolls the thumb on the right hand. Unlike fingers, thumbs are rolled on the ink slab toward the subject's body. Thus, on the right hand, the thumb is rolled from right to left.

■ **3)** Next, the operator records the prints on the record card. Making sure the subject's forearm and hand are relaxed, the operator rolls the finger from nail edge to nail edge on the fingerprint record card using only slight pressure. The operator's left index finger and thumb hold the subject's finger in place during recording (Fig. 4).

The first joint of the finger—the area extending from the fingerprint to the crease line—is the area to be recorded. When completing the roll of a finger, the operator gently lifts the finger upward so that the edge of the impression will not be smudged. These steps are repeated for the remaining fingers on the right hand. Upon completion, the thumb on the right hand is recorded, and the procedure is repeated for the fingers and thumb on the left hand.

■ **4)** Plain impressions are recorded last, at the bottom of the record card. The operator and subject assume the same positions as when rolling prints.

First, the operator presses the subject's right thumb straight down on the ink surface, without rolling. Then the thumb is pressed straight down on the square provided on the record card, without rolling.

■ **5)** Next, the operator simultaneously presses the subject's four fingers (on the right hand) straight down on the inking surface (Fig. 5). Keeping the fingers together, the operator then simultaneously presses the fingers onto the card in the space provided (Figs. 6 and 7). These steps are then repeated for the left hand.



Fig 4: Then the operator records the print onto the record card.



Fig 5: The operator inks fingers for the plain impression record at the bottom of the card.



Fig 6: The operator simultaneously presses all four fingers straight down on the record card.



Fig 7: This is a closer look at how an operator records the plain impressions.

FINGERPRINT TAKING AND RECORDING PRODUCTS



SIRCHIE® pads may be used with any record form

- **PERMANENT INK**
 - **LIGHTWEIGHT (3.7 OUNCES)**
 - **TEMPERATURE USE: 32°F TO 150°F**
 - **LIFETIME MOLDED CASE**

The thermal-impregnated fingerprint ink is non-fading and dries on-contact in seconds. Ink rises to the surface as required through capillary action of the microreticulated thermoplastic resin. Recorded fingerprints from this pad are accepted by state and federal agencies. The Porelon® pad is available in pocket (field use) and desk (permanent-mounting) models. Replacement pads are also available.

CATALOG NO.	DESCRIPTION	PRICE
FPT267	POCKET MODEL	\$21.50
FPT268	DESK MODEL W/BRACKETS	\$21.50
FPT268A	REPLACEMENT PAD ONLY (5.0" x 2.5" x 0.25")	\$15.95

POCKET AND DESK MODEL PORELON® PADS

- **NO INKING**
- **NO ROLLERS**
- **NO INK PLATES**
- **NO SLAB CLEANER**

THE **SIRCHIE®** PORELON® FINGERPRINT PAD

This pocket-sized pad, introduced by **SIRCHIE®** 20 years ago, is the accepted STANDARD by law enforcement worldwide. Each pad may be used to record thousands of fingerprints. A two-year supply of ink is impregnated in each pad (based on 75°F with lid closed after use), and is excellent for use in the field or office.



STAINFREE™ PORELON® FINGERPRINT PADS

The advent of Porelon® pads for fingerprinting both simplified and improved the process for obtaining classifiable prints. After recording the appropriate plain and rolled fingerprints (or palm prints) with a STAINFREE™ pad, cleanup by using a dry paper towel to remove the excess. The prints recorded are clear, legible and ready for processing. Any record form may be used with excellent results. Outstanding for field use, including recording elimination prints at the crime scene.*



The picture on the far left shows a finger inked on a STAINFREE™ ink pad. When fingers are rubbed with a dry towel, the ink disappears (picture immediately left).

**STAINFREE™ is not recommended for computer input.*

CATALOG NO.	DESCRIPTION	PRICE
FPT267S	STAINFREE™ POCKET MODEL	\$32.95
FPT268S	STAINFREE™ DESK MODEL	\$32.95
FPT268AS	REPLACEMENT PAD ONLY	\$21.95



MICRO AND MINI PORELON® FINGERPRINT PADS

from **SIRCHIE**®—a Porelon® fingerprint pad that really fits in a pocket and gives you the same reliable, detailed prints as our regular Porelon® pad. Primarily for single fingerprint recording on checks, documents, traffic summons, etc.



No. PMP1002

APPLICATIONS

- Elimination fingerprints at the crime scene
- Driver's licenses
- Identification badges
- Children's records
- Traveler's checks
- Evidence marking
- Stocks, bonds and other documents
- Many, many more uses

Leading Particulars

- Permanent, non-fading ink
- Instant drying
- Just touch the pad and record the print on any porous surface
- Thousands of prints—no re-inking



Specifications	PMP100/PMP100S
Net Weight	0.5 oz. (15 g)
Dimensions	5/8" x 1 5/8" dia. (1.6 cm x 4 cm dia.)
Case	Polypropylene with live hinge



Specifications	PMP1002/PMP1002S
Net Weight	0.9 oz. (26 g)
Dimensions	5/8" x 2" dia. (1.6 cm x 5.1 cm dia.)
Case	Polypropylene with live hinge
Color	Black

CATALOG NO.	DESCRIPTION	PRICE
PMP100.....	MICRO PORELON® PAD	\$10.95
PMP1002.....	MINI PORELON® PAD	\$11.50
PMP100S	MICRO STAINFREE™ PORELON® PAD	\$12.50
PMP1002S	MINI STAINFREE™ PORELON® PAD	\$13.25

FOR STAINFREE™ CERAMIC PADS, SEE PAGE 49A



No. PMP200

CITAKE™ PATROL OFFICER POCKET PORELON® KIT

This is an ideal kit for the traffic officer. Single fingerprints may be taken at the scene with almost instantaneous cleanup. One micro Porelon® pad and 6 hermetically sealed, disposable ink cleaner towelettes are packaged in a convenient nylon pocket case.

Specifications	PMP200/PMP200S
Net Weight	1.8 oz. (51 g)
Dimensions	3 3/8" x 3 3/8" x 1 1/2" (8.6 cm x 8.6 cm x 3.8 cm)

- No. PMP200 consists of:**
- 6-No. FPT2541 Ink Cleaner Towelettes
 - 1-No. PMP100 Micro Porelon® Fingerprint Pad
 - 1-No. PMP2001 Nylon Pocket Case

CATALOG NO.	CITAKE™ POCKET PORELON® KIT	PRICE
PMP200.....	REGULAR PORELON® KIT	\$14.25
PMP200S	STAINFREE™ PORELON® KIT	\$16.95

THE PRINTMATIC™ ADVANTAGE

SIRCHIE®'s PRINTMATIC™ pre-inked roller successfully combines the advantages of the Porelon® pad and the ink slab and roller methods of fingerprint taking. Those advantages include the excellent clarity obtainable with a properly executed slab and roller print and the ease and speed associated with the Porelon® pad method.



The slab and roller method has survived over the years primarily for two reasons.

First, the quality of the inked area on the slab can be seen and judged prior to inking and rolling the fingers.

Second, when a proper layer of ink is applied, the rigid slab surface and the thin ink layer of ink tend to prevent the over-inking of fingers.

Despite the advantages, there are several disadvantages of the ink slab and roller method that cause many departments to avoid it. This method requires a relatively skilled technician to roll a thin and even layer of ink necessary to obtain ex-

ceptional fingerprint impressions. If the ink layer is too thick, spotty or uneven, it's likely the technician will record poor prints. In fact, excess ink is the leading cause of poor fingerprint impressions. Another disadvantage of this method is that it may be messy—ink may spatter and cleanup may be quite a task.

However, the revolutionary SIRCHIE® PRINTMATIC™ pre-inked Porelon® roller successfully eliminates the disadvantages of the ink slab and roller method while retaining the advantages. The PRINTMATIC™ automatically applies a thin and even layer of ink onto an ink slab, regardless of the operator's skill.

The reason is because the PRINTMATIC™'s ink reservoir is in the roller! In addition, cleanup is much easier because there is not much ink left on the slab after fingerprints are rolled.

How It Works

Porelon® is a microporous plastic that acts both as an ink reservoir and an ink delivery system.

Ink is held in thousands of interconnected pores within the roller. Larger interior pores provide high-ink capacity and permit the use of highly pigmented inks for high-contrast impressions.

Ink is gradually and evenly delivered to the surface through a particularly fine-pored outer layer by capillary action.

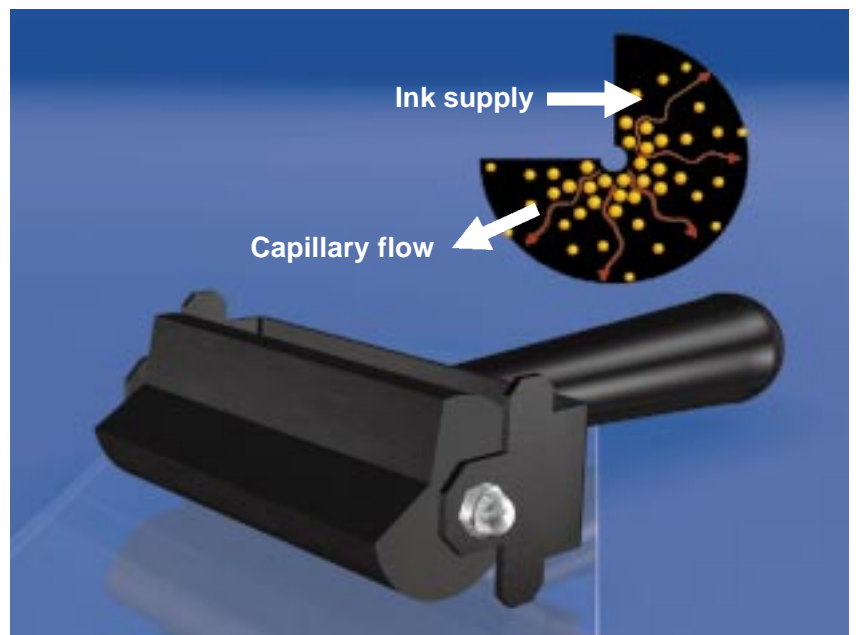

CONVENIENCE OF A PAD, PERFORMANCE OF A SLAB



1
The operator applies ink to the slab with the No. PIP100.



2
Prints are rolled and recorded in the usual manner.



3
Ink is picked up by the finger and recorded on the record card with very clear detail.



4
Cleanup is simple.

Using the PRINTMATIC™

The photographs above illustrate the PRINTMATIC™'s simplicity and effectiveness. Below, the photographs are described in greater detail.

1. The operator uses the PIP100 to apply several light-pressure, one-way strokes of ink onto the slab. A thin, even layer of ink is automatically applied to the slab. (see photo #1).
2. The operator rolls and records fingerprints onto the record card, one at a time, in the same manner as is standard with other methods of fingerprint taking. (see photo #2).
3. A closer examination of the slab reveals that the thin layer of ink is almost completely picked up by the rolling of the finger onto the slab. As a result, the subsequent print displays clear fingerprint ridge detail (see photo #3).
4. The operator is able to easily clean the slab simply by wiping it off with an ink cleaner towelette (see photo #4).

PRINTMATIC™ PORELON® FINGERPRINT INK ROLLER

The PIP100 is supplied with a hinged metal enclosure that is designed to prevent environmental contamination and protect the roller surface between uses. A comfortable thermoset plastic handle allows for optimum roller control.

Specifications

Net Weight	1 lb. (0.45 kg)
Dimensions	6" x 4 5/8" x 1 3/4" (15.2 cm x 11.7 cm x 4.5 cm)

CATALOG NO.	PRINTMATIC™ PORELON® INK ROLLER	PRICE
PIP100 SYSTEM	\$32.95
PIP100R REPLACEMENT ROLLER	\$21.95

(SEE PAGE 10 FOR HORIZONTAL CONFIGURATIONS)

FINGERPRINT TAKING AND RECORDING PRODUCTS



An operator uses the No. PIP100H to apply ink to an inking slab.

PRINTMATIC™ HORIZONTAL ROLLER

The **PRINTMATIC™** Horizontal Roller, or PIP100H, is a handy, versatile version of our superb new **PRINTMATIC™** pre-inked Porelon® fingerprint roller. The PIP100H is designed for horizontal (parallel) ink-rolling of the slab. The unit's high-impact, ABS-plastic tubular housing prevents environmental contamination when the roller is not in use. And the PIP100H features a comfortable, easy-grip thermoset plastic handle. The **PRINTMATIC™** Horizontal Roller is an excellent choice for replacement of ink and roller assemblies used in field fingerprint taking kits.

Specifications

Net Weight
Dimensions

6.6 oz. (188 g)
8 1/2" x 1 3/4" dia.
(21.6 cm x 4.5 cm dia.)



Leading Particulars

- Tubular housing to protect roller from the environment
- Deposits a uniform, ultra-thin layer of ink on the slab every time
- Virtually impossible to over ink fingers
- Good for thousands of impressions



CATALOG NO. PIP100H HORIZONTAL SYSTEM PRICE: \$32.95
CATALOG NO. PIP100R REPLACEMENT ROLLER PRICE: \$21.95



No. AP300PIP

AUTOPALM® IMAGE TRANSFER ROLLER ASSEMBLY

Use either the PIP100 or PIP100H **PRINTMATIC™** roller with the AP300PIP to roll and record palm prints. The AP300PIP is a high-quality, bearing-mounted image transfer roller assembly, which provides the proper surface for creating accurate palm print images.

Specifications

Net Weight
Dimensions

11.9 oz. (338 g)
5 1/2" x 5" x 4 1/2"
(14 cm x 12.7 cm x 11.4 cm)

No. AP300PIP consists of:

- 1-No. AP2004 Image Transfer Roller
- 1-No. AP3001 Foam Roller Frame Assembly
- 4-No. SFL288 Rubber Feet, Adhesive Mount



The operator inks the subject's palm with the No. PIP100 **PRINTMATIC™** Pre-Inked Porelon® Roller (the No. PIP100H also may be used).



The operator rolls the palm onto card using the No. AP300PIP.



The resultant palm print displays clear ridge detail.

CATALOG NO. AP300PIP ... ROLLER ASSEMBLY ONLY PRICE: \$21.95

PRINTMATIC™ POSTMORTEM INK ROLLER SYSTEM

This version of our PRINTMATIC™ pre-inked roller is designed specifically for recording fingerprints of the deceased. Ink is rolled directly onto the finger bulbs, which are then immediately applied to a postmortem record card. The rolling action helps avoid ink smearing. A thermoset plastic handle ensures operator control. The Postmortem Ink Roller is supplied in a metal housing to protect the roller surface from dust and other environmental contaminants.

Specifications

Net Weight	11.5 oz. (326 g)
Dimensions	6" x 2 5/8" x 1 3/4" (15.2 cm x 6.7 cm x 4.4 cm)



CATALOG NO.	DESCRIPTION	PRICE
PM283PIP	REGULAR SYSTEM	\$25.50
PM283PIPR	REPLACEMENT ROLLER	\$18.75

PRINTMATIC™ POSTMORTEM HORIZONTAL INK ROLLER SYSTEM

The Postmortem Horizontal Ink Roller is intended primarily for recording fingerprints of the deceased, although it may be used for many other field fingerprinting situations. The rolling action minimizes potential ink smearing and over-inking of the finger. Ink is always ready. The PM283PIPH is supplied with a protective tubular housing to prevent environmental contamination.

Specifications

Net Weight	4.3 oz. (122 g)
Dimensions	6 1/2" x 1 3/4" dia. (16.5 cm x 4.4 cm dia.)



An operator inks fingers with the No. PM283PIPH prior to recording prints.

CATALOG NO.	DESCRIPTION	PRICE
PM283PIPH	HORIZONTAL SYSTEM	\$27.50
PM283PIPR	REPLACEMENT ROLLER	\$18.75

FINGERPRINT TAKING AND RECORDING PRODUCTS

PRINTMATIC™ FINGERPRINT TAKING OUTFITS

These fingerprint taking outfits feature **SIRCHIE**®'s superb **PRINTMATIC**™ pre-inked roller system. Outfits are supplied with a **PRINTMATIC**™ roller system, a glass inking slab, and a choice of one, two or three fingerprint record cardholder(s). The double and triple cardholder units are ideal for multiple fingerprint records. Integral mounting brackets on each outfit allow for easy mounting to a desk or tabletop. The **PRINTMATIC**™ ink roller is supplied in a rugged metal housing designed to protect the roller and prevent environmental contamination. Each outfit features a platinum-finished frame, a brushed, nickel-plated cardholder(s), and a clear, anodized cardholder frame.



No. PIP400

No. PIP300

No. PIP200

- Units consist of:**
- 1-No. FPT205 4" x 10" Glass Inking Slab
 - 1-No. FPT264 Regular Fingerprint Cardholder (PIP200 only)
 - 2-No. FPT264 Regular Fingerprint Cardholders (PIP300 only)
 - 3-No. FPT264 Regular Fingerprint Cardholders (PIP400 only)
 - 1-No. PIP100 **PRINTMATIC**™ Porelon® Fingerprint Ink Roller System

CATALOG NO.	DESCRIPTION	PRICE
PIP200	WITH SINGLE CARDHOLDER	\$76.50
PIP300	WITH DOUBLE CARDHOLDER	\$84.50
PIP400	WITH TRIPLE CARDHOLDER	\$91.95

DISPOSABLE INKED STRIPS

It is difficult to over-ink fingers with the Disposable Inked Strips because they feature a thin layer of **SIRCHIE**®'s famous fingerprint ink sandwiched between two thin sheets of plastic. In fact, the ink strips produce excellent fingerprint images. They're an ideal choice for recording elimination prints at the crime scene, as well as for child identification programs and other field applications.



An operator exposes the ink strip surface.

CAT. NO.	DESCRIPTION	PRICE
SIS15	5" x 1" INK STRIPS/PER 2,400	\$92.00
SIS3104C	10" x 3" INK STRIPS/PER 400	\$84.00
SIS310C	10" x 3" INK STRIPS/PER 100	\$24.00
SIS354C	5" x 3" INK STRIPS/PER 400	\$48.00
SIS358C	5" x 3" INK STRIPS/PER 800	\$84.00
SIS35C	5" x 3" INK STRIPS/PER 100	\$12.00
SIS610C	6" x 10" INK STRIPS/PER 100	\$60.00
SIS6102C	6" x 10" INK STRIPS/PER 200	\$84.00
SISH35X	INK STRIP HOLDERS, 5" x 3"	\$6.95/10
SISH310X	INK STRIP HOLDERS, 10" x 3"	\$12.95/10
SISH610X	INK STRIP HOLDERS, 6" x 10"	\$25.95/10



These are the resultant fingerprints using **SEARCH**® Ink Strips.

FINGERPRINT INK

THIS IS THE WORLD'S BEST FINGERPRINT SLAB INK! It is formulated for fingerprint work only. The densely-black ink is free-flowing, easily rolled and dries quickly on paper—but will remain soft and usable on a slab for days. This ink is not adversely affected by extreme temperature changes. It is used by large and small identification departments throughout the world.

CATALOG NO.	FINGERPRINT INK, TUBE	PRICE
230T	2 OZ. (59 ML)	\$4.75
231T	4 OZ. (118 ML).....	\$6.50



Apply Spray Smooth to an ink slab and roll it like standard tube ink.

SPRAY SMOOTH FINGERPRINT INK

SIRCHIE®'s standard, high-quality fingerprint ink is available in a handy aerosol can. Simply spray it on the slab and roll it smooth like standard tube ink. It's very efficient and easy to use. It does not contain any fluorocarbons. Net weight: 4.5 oz.

CATALOG NO. 232T PRICE: \$11.25

LANSBERRY'S RIDGE BUILDER

Lansberry's Ridge Builder is a unique solution that will bring excellent definition and clarity to fingerprint ridge structures. Lansberry's Ridge Builder is applied to the finger bulbs before fingerprinting—making it possible to obtain legible fingerprints from brick masons, agricultural workers, the elderly, or anyone else who has poor fingerprint ridge structure. This product will help increase the number of successful latent print searches and subsequent comparisons by ensuring better initial fingerprint recordings.

Available in two forms: liquid and disposable pad. Apply liquid with a cotton swab. Or wipe disposable pad on fingers before fingerprinting.



CATALOG NO. LRB20	RIDGE BUILDER, 4 OZ. LIQUID	PRICE: \$12.95
CATALOG NO. LRB20T	RIDGE BUILDER, 100 DISPOSABLE PADS	PRICE: \$24.95

FINGERPRINT TAKING AND RECORDING PRODUCTS

SEARCH® SUPER FINGERPRINT INK ROLLER

Shown with No. FPT205 glass inking slab. See page 15.

The **SEARCH®** Super Fingerprint Ink Roller is one of the finest ink rollers made. The roller assembly is designed to ensure operator comfort for effective ink spreading. And the roller's black-wrinkle-finished steel frame provides the proper weight and balance for optimum control. The roller features a high-density, medium-soft composition rubber that will withstand repeated cleaning with harsh solvents. The roller bracket is designed to prevent the roller from touching the inking table when not in use.

Specifications	FEL100	FRR400
Net Weight	9 oz. (255 g)	3.7 oz. (105 g)
Dimensions	7 1/4" x 4 7/8" x 1 7/8" (18.4 cm x 12.4 cm x 4.8 cm)	3 7/8" x 1 1/4" dia. (9.8 cm x 3.2 cm dia.)

Leading Particulars

- Finish: Epoxy-painted, black wrinkle
- Materials: Aluminum alloy and cold-rolled steel
- Roller: Centerless ground, Buna-N black, 50 durometer

CATALOG NO. FEL100 ROLLER, 4" PRICE: \$14.95
CATALOG NO. FRR400 ... REPLACEMENT (ONLY) ROLLER PRICE: \$6.50

UNIFIED FINGERPRINT INK ROLLERS

SIRCHIE®'s Unified Fingerprint Ink Rollers are effective and economical. Available in a 2", 3", and 4" version, the unified roller features a one-piece design that ensures the integrity of the complete roller assembly. The design also prevents the roller from touching the inking table when not in use. The rugged, aluminum handle and rubber grip area allow for operator comfort as well as control. The unit's medium-soft, high-density rubber roller element will withstand repeated cleaning with harsh solvents.

Specifications	FPR200	FPR300	FPR400
Net Weight	4.2 oz. (119 g)	5.4 oz. (153 g)	6.5 oz. (184 g)
Dimensions	7 1/2" x 3" x 1 5/8" (19 cm x 7.6 cm x 4.1 cm)	7 1/2" x 4" x 1 5/8" (19 cm x 10.2 cm x 4.1 cm)	7 1/2" x 5" x 1 5/8" (19 cm x 12.7 cm x 4.1 cm)

No. FPR400



No. FPR200

No. FPR300

Leading Particulars:

- Finish: Vinyl-clad aluminum platinum (gray)
- Materials: Aluminum alloy and cold rolled steel
- Roller: Centerless ground, Buna-N black, 50 durometer

CATALOG NO.	UNIFIED FINGERPRINT INK ROLLER	PRICE
FPR200	2"	\$8.75
FPR300	3"	\$9.75
FPR400	4"	\$11.95
UNIFIED REPLACEMENT (ONLY) ROLLER		
FRR200	2"	\$4.50
FRR300	3"	\$5.50
FRR400	4"	\$6.50

SEARCH® EASY-GRIP FINGERPRINT INK ROLLERS

This line of quality ink rollers features an unbreakable, custom-designed thermoset plastic handle for maximum operator comfort and control. The frame design prevents the roller from touching the inking table when not in use. A high-density, medium-soft rubber roller element withstands repeated cleaning with harsh solvents. The roller is easy to disassemble when replacement parts are required.

Specifications	FPT262	FPT262A	FPT262B
Net Weight	4.7 oz. (133 g)	5.9 oz. (167 g)	7 oz. (198 g)
Dimensions	5 5/8" x 2 7/8" x 1 1/2" (14.3 cm x 7.3 cm x 3.8 cm)	5 5/8" x 3 7/8" x 1 1/2" (14.3 cm x 9.8 cm x 3.8 cm)	5 5/8" x 4 7/8" x 1 1/2" (14.3 cm x 12.4 cm x 3.8 cm)

Leading Particulars

- Finish: Vinyl-clad aluminum platinum (gray)
- Frame Materials: Aluminum alloy and steel
- Handle: Cast plastic, black
- Roller: Centerless ground, Buna-N black, 50 durometer

No. FPT262B



No. FPT262



No. FPT262A



CATALOG NO.	ROLLER	PRICE
FPT262	2"	\$8.75
FPT262A	3"	\$9.95
FPT262B	4"	\$12.25

REPLACEMENT (ONLY) ROLLER

FRR200	2"	\$4.50
FRR300	3"	\$5.50
FRR400	4"	\$6.50



No. FPT258

No. FPT260

No. FPT205

INKING SLABS

These high-quality, super-smooth inking slabs provide optimum versatility and portability. Two polished stainless steel versions are available, as is a 4" x 10" glass slab. The FPT258 and FPT260 stainless steel inking slabs feature predrilled mounting holes.

*Inking slabs are pictured with
No. FEL100 Super
Fingerprint Ink Roller
See page 14.*

CATALOG NO.	INKING SLABS	PRICE
FPT258	STAINLESS STEEL, 4" x 10" (10.2 CM x 25.4 CM)	\$11.75
FPT260	STAINLESS STEEL, 5" x 12" (12.7 CM x 30.5 CM).....	\$13.75
FPT205 ..	GLASS, 4" x 10" x 3/16" (10.2 CM x 25.4 CM x 0.5 CM) ...	\$10.95

FINGERPRINT TAKING AND RECORDING PRODUCTS

SEARCH® REGULAR FINGERPRINT CARDHOLDER

The **SEARCH®** Regular Fingerprint Cardholder is **SIRCHIE®**'s most popular. This cardholder holds standard 8" x 8" fingerprint record cards. It holds a card firmly in place—preventing slippage or smudging. The FPT264 features a rugged, all-steel assembly, a brushed-nickel-finished steel base and a vinyl covered aluminum frame. Each unit is designed with integral mounting brackets for easy desk or tabletop mounting.



Leading Particulars

- Cardholder Base: Nickel plating and vinyl-clad, platinum (gray)
- Cardholder Materials: Aluminum alloy and steel

CATALOG NO. FPT264 CARDHOLDER PRICE: \$17.95

SEARCH® SUPER FINGERPRINT CARDHOLDER

The **SEARCH®** Super Fingerprint Cardholder is an exceptional unit because it may be used on any flat surface without permanent mounting. It features an overlapping lip along the front of the cardholder base that “locks” onto a table or desk top. Two versions of the **SEARCH®** Super Fingerprint Cardholder are available. The first, FEL101N features a non-slip, neoprene rubber base for true portability. The second, FEL101S, features two pre-drilled holes for permanent mounting. Each unit’s vinyl-clad aluminum frame is attached to a hardwood base.

Leading Particulars

- Cardholder Finishes: Walnut stain and vinyl-clad, platinum (gray)
- Cardholder Materials: Hardwood and aluminum alloy



CATALOG NO.	CARDHOLDER	PRICE
FEL101S	WITH MOUNTING HOLES	\$18.50
FEL101N	WITH NON-SLIP BASE	\$18.95

SEARCH® CLAMP-ON FINGERPRINT CARDHOLDER

This fingerprint cardholder is an excellent choice for use at various locations because it may be mounted on almost any flat surface. The cardholder features an integral thumb-screw clamp that provides a stable and slip-free mount. And an overlapping "lip" allows for instant positioning. The unit holds all standard 8" x 8" record cards.

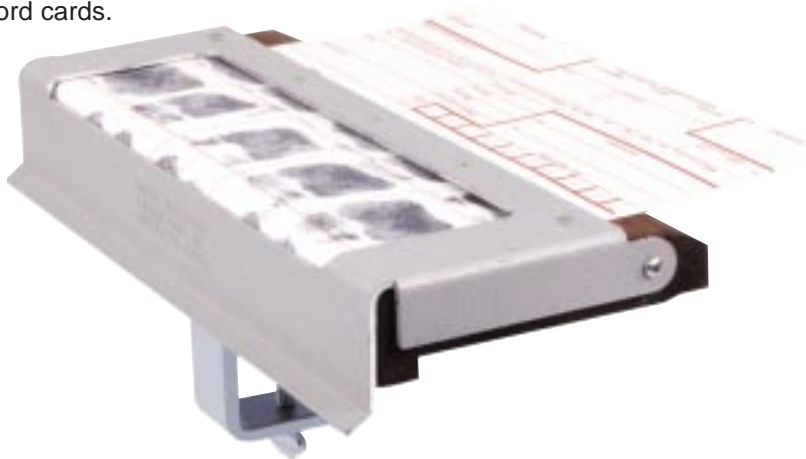

- Leading Particulars**
- Cardholder Finishes: Walnut stain and vinyl-clad, platinum (gray)
 - Cardholder Materials: Hardwood and aluminum alloy
 - Mounting Clamp: Plated steel with thumbscrew

CATALOG NO. FEL696 PRICE: \$25.95

SEARCH® DUPLEX AND TRIPLEX FINGERPRINT CARDHOLDERS

The **SEARCH®** Duplex and Triplex Fingerprint Cardholders are an ideal choice when multiple fingerprint records are required. Cardholders are permanently mounted on a vinyl-covered aluminum frame. Each frame features pre-drilled integral mounting brackets.

Specifications	FPT264A	FPT264B
Net Weight	2.4 lbs. (1.09 kg)	3.4 lbs. (1.54 kg)
Dimensions	26 1/4" x 4 7/16" x 1 9/16" (66.7 cm x 11.3 cm x 4 cm)	39 1/4" x 4 7/16" x 1 9/16" (99.7 cm x 11.3 cm x 4 cm)

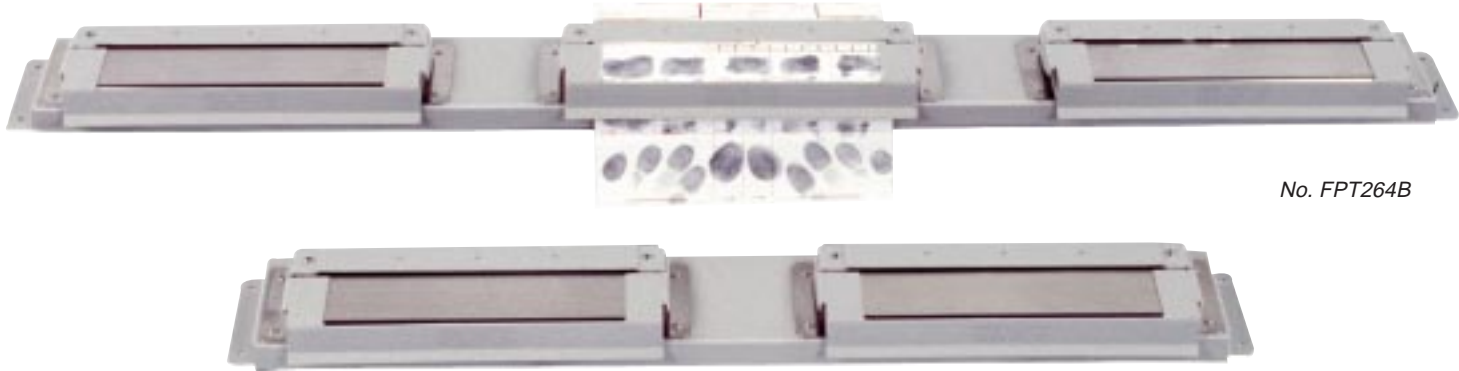

No. FPT264B

No. FPT264A

- Leading Particulars**
- Cardholder Finishes: Nickel plating and vinyl-clad, platinum (gray)
 - Cardholder Materials: Aluminum alloy and steel

CATALOG NO.	DESCRIPTION	PRICE
FPT264A	DUPLEX (2-NO. FPT264 CARDHOLDERS)	\$32.95
FPT264B	TRIPLEX (3-NO. FPT264 CARDHOLDERS)	\$43.95

FINGERPRINT TAKING AND RECORDING PRODUCTS

PORELON® FINGERPRINT TAKING COMBINATIONS

The Porelon® Fingerprint Taking Combinations feature a Porelon® fingerprint pad and cardholder(s) mounted on a common base. These combinations are available with one, two or three cardholder(s) and a choice of either a regular or STAINFREE™ Porelon® fingerprint pad. Each platinum-finished, aluminum base features integral mounting brackets with pre-punched holes for mounting.

Specifications	FPT269/FPT269S	FPT269A/FPT269AS	FPT269B/FPT269BS
Net Weight	2.1 lbs. (0.95 kg)	3.2 lbs. (1.47 kg)	4.1 lbs. (1.86 kg)
Dimensions	26 1/4" x 4 7/16" x 1 9/16" (66.7 cm x 11.3 cm x 4 cm)	39 1/4" x 4 7/16" x 1 9/16" (99.7 cm x 11.3 cm x 4 cm)	46" x 4 7/16" x 1 9/16" (116.8 cm x 11.3 cm x 4 cm)

Leading Particulars

- Cardholder Mount: Vinyl-clad aluminum, platinum (gray)
- Brackets for table mounting
- Efficient, durable and attractive

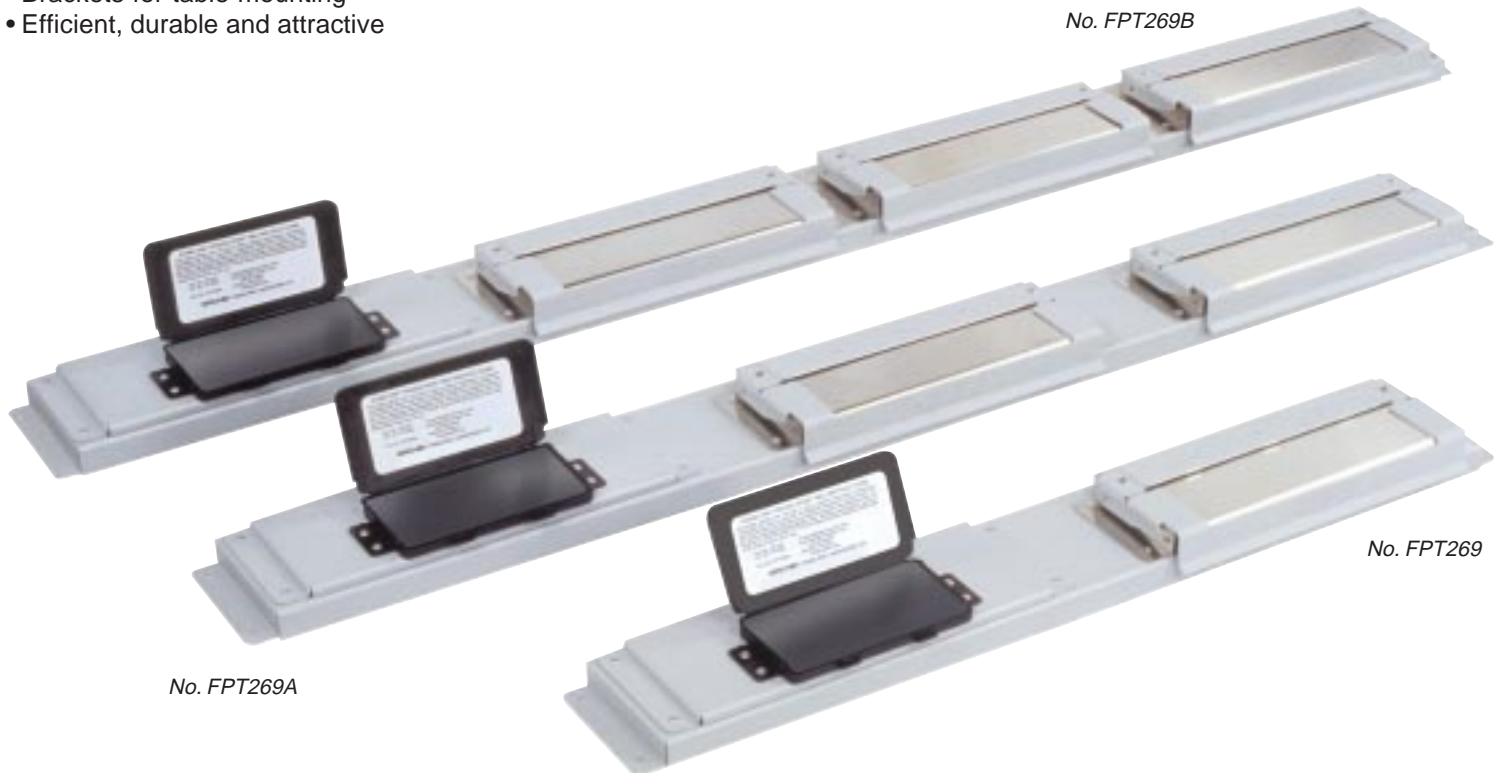

Units consist of:

- 1-No. FPT264 Regular Fingerprint Cardholder (FPT269 only)
- 2-No. FPT264 Regular Fingerprint Cardholders (FPT269A only)
- 3-No. FPT264 Regular Fingerprint Cardholders (FPT269B only)
- 1-No. FPT268 Porelon® Fingerprint Pad
- 1-No. FPT268S STAINFREE™ Porelon® Fingerprint Pad (FPT269S, FPT269AS and FPT269BS only)

CATALOG NO.	FINGERPRINT TAKING COMBINATIONS	PRICE
FPT269	REGULAR PORELON® SINGLE CARDHOLDER	\$42.90
FPT269A	REGULAR PORELON® DOUBLE CARDHOLDER	\$52.20
FPT269B	REGULAR PORELON® TRIPLE CARDHOLDER	\$64.20
FPT269S	STAINFREE™ SINGLE CARDHOLDER	\$55.14
FPT269AS	STAINFREE™ DOUBLE CARDHOLDER	\$65.40
FPT269BS	STAINFREE™ TRIPLE CARDHOLDER	\$76.20

INK SLAB FINGERPRINT TAKING COMBINATIONS

The **SEARCH®** Ink Slab and Cardholder Combinations feature a high-quality, stainless steel ink slab and one, two or three cardholder(s). The ink slab and cardholder(s) are mounted on a common base with integral mounting brackets and pre-punched holes for mounting. Each unit's all-metal construction ensures years of reliable service.

Leading Particulars

- Cardholder Mount: Vinyl-clad aluminum, gray (platinum)
- Ink Roller Slab: Bright nickeloid 0.032"-thick
- Surface mountable

Units consist of:

- 1-No. FPT258 Ink Slab, Mounted 4" x 10"
- 1-No. FPT264 Regular Fingerprint Cardholder (SCC500S only)
- 2-No. FPT264 Regular Fingerprint Cardholders (SCC400D only)
- 3-No. FPT264 Regular Fingerprint Cardholders (SCC300T only)



No. SCC300T



No. SCC400D



No. SCC500S

*Ink and ink rollers not supplied.
See pages 13-15.*

CATALOG NO.	INK SLAB COMBINATIONS	PRICE
SCC500S	SINGLE CARDHOLDER	\$33.75
SCC400D	DOUBLE CARDHOLDER	\$41.25
SCC300T	TRIPLE CARDHOLDER	\$48.95



No. FC279S

ROTARY SLAB AND CARDHOLDER OUTFITS

SIRCHIE®'s Rotary Slab and Cardholder Outfits offer a unique combination for rolling and recording fingerprints. Their design virtually eliminate excessive movement by both the operator and the subject. The circular inking slab rotates 360-degrees and provides a much larger inking surface than standard ink slabs. Outfits are available with one or two cardholder(s) mounted on a laminated base.

Units consist of:

- 1-No. FPT264 Regular Fingerprint Cardholder (FC279S only)
- 2-No. FPT264 Regular Fingerprint Cardholder (FC279D only)
- 1-No. Rotary Slab, 10" diameter

Leading Particulars

- Base: Gray Formica® laminate
- Rotary Slab: Bearing-mounted

CATALOG NO.	ROTARY SLAB OUTFIT	PRICE
FC279S	SINGLE CARDHOLDER	\$89.25
FC279D	DOUBLE CARDHOLDER	\$99.25

FINGERPRINT TAKING AND RECORDING PRODUCTS

SEARCH® INK CLEANER TOWELETTES



**SAFE!
SANITARY!
HERMETICALLY SEALED!**

The **SEARCH®** Ink Cleaner Towelettes are individual, disposable ink-cleaning towels. They're napkin-size, of wet strength and saturated with ink solvent that is easy on skin and mildly fragrant. They will remove fingerprint ink or grime from hands quickly. Excellent for field kits or office. These towelettes are not the same as those sold in retail stores which contain a mild detergent. The **SEARCH®** Ink Cleaner Towelettes features **SIRCHIE®**'s special formulation. Plus, they're sanitary and available in hermetically sealed packages.

CATALOG NO.	INK CLEANER TOWELETTES	PRICE
FPT254	100 EACH	\$12.00
FPT255	1000 EACH	\$110.00



sirch kleen™ FINGERPRINT INK REMOVER PADS

sirch kleen™ Fingerprint Ink Remover Pads are individually pre-moistened pads that will quickly and easily remove fingerprint ink. **sirch kleen™** pads are sanitary, disposable and leave the hands clean and fresh with a gentle skin conditioner. The pads also may be used to clean ink slabs when necessary. They are packaged one hundred pads to a container with a resealable lid.



CATALOG NO. FPT900A	100 EACH	PRICE: \$10.95
---------------------------	----------------	----------------

SPRAY MAGIC HAND CLEANER

SIRCHIE®'s Spray Magic Hand Cleaner is a very effective, non-fluorocarbon, waterless hand cleaner. It is excellent for cleaning fingerprint ink from hands, especially after palm printing. This hand cleaner will also remove grease, oil and other soil. After application, wipe off with a cloth or paper towel.

Specifications	
Net Weight	12 oz. (397 g)
Dimensions	7 7/8" x 2 3/4" dia. (20 cm x 7 cm dia.)
Volume	16 oz. (473 mL)



CATALOG NO. 236T16 16 OZ. AEROSOL..... PRICE: \$11.25



SLAB AND ROLLER CLEANER

SIRCHIE®'s Slab And Roller Cleaner is a fast-acting solvent used for removing fingerprint ink stains from rollers and ink slabs. It is conveniently packaged in an easy-to-use, non-fluorocarbon aerosol can. Simply spray on and wipe away the ink with a paper towel or cloth.

Specifications	233T	234T
Net Weight	4.5 oz. (128 g)	11 oz. (312 g)
Dimensions	5 5/8" x 2 1/8" dia. (14.3 cm x 5.4 cm dia.)	7 7/8" x 2 5/8" dia. (20 cm. x 6.7 cm dia.)
Volume	6 oz. (177 mL)	16 oz. (473 mL)

CATALOG NO. SLAB AND ROLLER CLEANER PRICE

233T 6 OZ. AEROSOL (177 ML)..... \$9.00
234T 16 OZ. AEROSOL (473 ML)..... \$11.25

WATERLESS MAGIC CLEANER

SIRCHIE®'s Waterless Magic Cleaner effectively removes fingerprint ink and stains from fingers and hands. As the name implies, there is no need to add water. This hand cleaner is also very useful for cleaning fingerprint powders from furniture and other items at the crime scene. Available in a regular or bulk size.

CATALOG NO. WATERLESS MAGIC CLEANER PRICE
FPT249 16 FL. OZ. (473 ML) \$5.75
FPT249AG 128 FL. OZ. (3.79 L) \$30.25



DISPOSABLE SLAB & ROLLER INK REMOVING TOWELS

Take the mess out of slab and roller fingerprinting with these large, disposable ink removing towels. Towels are pre-conditioned with ink-removing solvent. One individual towel will clean a 6" x 14" inked slab. Towels are packaged in quantities of 50 in a resealable plastic container. Net weight: 3.2 lbs. (1.46 kg).

CATALOG NO. DT999 TOWELS PRICE: \$21.95



FINGERPRINT TAKING AND RECORDING PRODUCTS

QUICK-KLEEN™ SLAB AND ROLLER CLEANER

The QUICK-KLEEN™ Slab and Roller Cleaner is an instant-cleaning solvent that immediately “bites” into excess fingerprint ink when cleaning ink rollers and slabs. It is ideal for quick and efficient cleanup—simply moisten a cloth or paper towel and wipe clean.

CATALOG NO.	QUICK-KLEEN™	PRICE
FPT250	32 FL. OZ. (946 ML)	\$10.95
FPT251	128 FL. OZ. (3.79 L)	\$27.50



SEARCH-O-LINE™ FINGERPRINT INK CLEANER

This cleaner is specifically formulated and manufactured for cleaning fingerprint ink from ink slabs, rollers and hands. SEARCH-O-LINE™ fingerprint ink cleaner is both nonflammable and pleasant smelling. This cleaner contains a germicidal agent and is advantageous for use by the technician as well as the subject being fingerprinted.

CATALOG NO.	SEARCH-O-LINE™	PRICE
FPT252	SEARCH-O-LINE™, 32 FL. OZ. (946 ML)	\$9.95
FPT253	SEARCH-O-LINE™, 128 FL. OZ. (3.79 L)	\$21.95

MAGIC ORANGE HAND CLEANERS

SIRCHIE®'s Magic Orange Waterless Hand Cleaner is now available with and without pumice. The cleaner removes gun oils, powdered inks, glue, tar, adhesives, mechanic's grease and of course, fingerprint ink. Magic orange is sold in two dispenser sizes. The 500 mL squeeze bottle is ideal for the fingerprint station and the 2,500 mL container is suited for use with the No. MB248DP dispenser at a cleaning station. *Dispenser sold separately.*

CATALOG NO.	MAGIC ORANGE	PRICE
MB247	WITH PUMICE, 2,500 ML	\$15.95
MB248	WITHOUT PUMICE, 2,500 ML	\$15.95
MB248PT	WITH PUMICE, 500 ML	\$5.50
MB248PS	WITHOUT PUMICE, 500 ML	\$5.50
MB248DP	MAGIC ORANGE DISPENSER	\$55.75



WATERLESS INK CLEANER

This waterless ink cleaner features a pleasant citrus scent and contains aloe, lanolin and jojoba. Available in a 1-gallon, self-dispensing container this cleaner comes with or without pumice and does not contain any petroleum solvents. Net weight: 8.4 lbs. (3.81 kg).

CATALOG NO. FPT248GP	1 GALLON WITH PUMICE	PRICE: \$26.25
CATALOG NO. FPT248GS	1 GALLON WITHOUT PUMICE	PRICE: \$26.25



PORELON® FINGERPRINT TAKING OUTFITS

SIRCHIE®'s Porelon Fingerprint Taking Outfits may be placed on any desk or table to achieve regulation height for rolling and recording fingerprints. Available with one or two fingerprint cardholder(s), each outfit comes with a regular or STAINFREE™ Porelon® pad. A built-in shelf on each unit is handy for storing supplies and components. Brackets are included with each outfit for wall mounting if desired.



No. PFT200A

**“Ride the wave with
SIRCHIE®”**

Leading Particulars

- Cabinet Finish: Vinyl-clad, platinum (gray) and epoxy-painted, black
- Cabinet Material: Aluminum alloy
- Storage Compartment: Dimensioned for standard card storage
- Brackets: Included for optional wall mounting



No. PFT100A

Outfits consist of:

- 1-No. FPT254 Ink Cleaner Towelettes, 100 each
- 2-No. FPT264 Regular Fingerprint Cardholders (PFT100A only)
- 1-No. FPT268 Porelon® Fingerprint Pad
- 1-No. FPT264 Regular Fingerprint Cardholder (PFT200A only)
- 1-No. FPT268S STAINFREE™ Porelon® Fingerprint Pad (PFT100AS and PFT200AS only)

CATALOG NO.	PORELON® FINGERPRINT TAKING OUTFIT	PRICE
PFT100A	REGULAR PORELON® DOUBLE CARDHOLDER	\$152.95
PFT200A	REGULAR PORELON® SINGLE CARDHOLDER	\$141.95
PFT100AS	STAINFREE™ DOUBLE CARDHOLDER	\$163.95
PFT200AS	STAINFREE™ SINGLE CARDHOLDER	\$152.95

FINGERPRINT TAKING AND RECORDING PRODUCTS

PRINTMATIC™ FINGERPRINT TAKING OUTFITS

SIRCHIE®'s **PRINTMATIC™** Fingerprint Taking Outfits feature the revolutionary **PRINTMATIC™** pre-inked Porelon® ink roller. Even a beginner may obtain fingerprints of exceptional quality using one of these outfits. That's because it is possible to roll a thin and very even ink layer with the **PRINTMATIC™**. In fact, it is almost impossible to over-ink a subject's fingers or palms. The outfits are available with one or two cardholder(s) and feature a storage compartment for supplies. Place either outfit on a desk or table to achieve regulation height for rolling and recording prints, or use the brackets included with each to mount to the wall. A rugged, hinged storage container protects the **PRINTMATIC™** when it is not in use.

Specifications	FPT274APIP	FPT275APIP
Net Weight	11.2 lbs. (5.08 kg)	12.4 lbs. (5.62 kg)
Dimensions	24 3/4" x 11 1/8" x 10 1/8" (62.9 cm x 28.3 cm x 25.7 cm)	35" x 11 1/8" x 10 1/8" (88.9 cm x 28.3 cm x 25.7 cm)

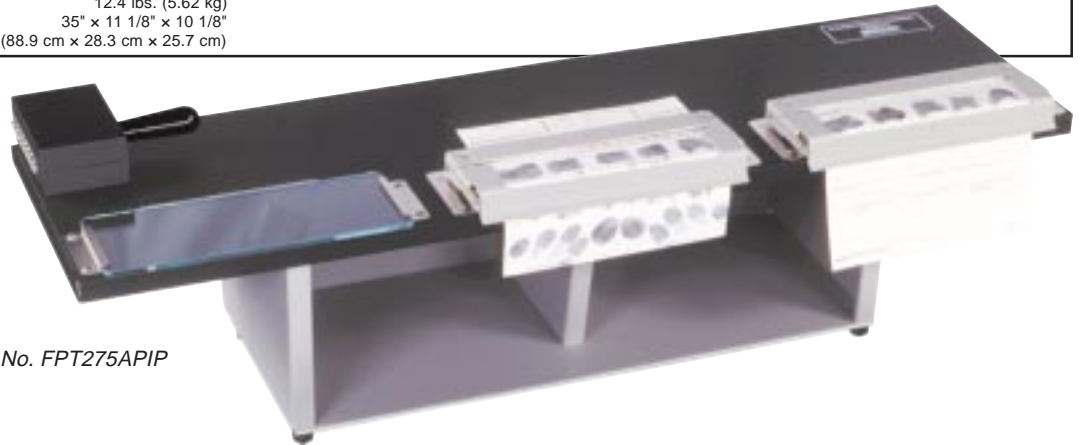

No. FPT275APIP

Leading Particulars

- Cabinet Finishes: Vinyl clad platinum (gray) and epoxy painted, black
- Cabinet Material: Aluminum alloy
- Storage Compartment: Dimensioned for standard card storage
- Brackets: Included for optional wall mounting



No. FPT274APIP

Units consist of:

- 1-No. FPT205 Inking Slab, Glass, 4" x 10"
- 1-No. FPT254 Ink Cleaner Towelettes, 100 each
- 1-No. FPT264 Regular Fingerprint Cardholder (FPT274APIP only)
- 2-No. FPT264 Regular Fingerprint Cardholders (FPT275APIP only)
- 1-No. PIP100 **PRINTMATIC™** Porelon® Fingerprint Ink Roller System

CATALOG NO.	PRINTMATIC™ OUTFIT	PRICE
FPT274APIP	SINGLE CARDHOLDER.....	\$170.50
FPT275APIP	DOUBLE CARDHOLDER.....	\$180.50

INK SLAB AND ROLLER FINGERPRINT TAKING OUTFITS

Place either of **SIRCHIE**®'s Ink Slab and Roller Fingerprint Taking Outfits on a desk or table to achieve regulation height for rolling and recording fingerprints. These outfits feature a stainless steel ink slab, a 3" unified fingerprint ink roller, a 2-ounce tube of fingerprint ink and are available with one or two fingerprint cardholder(s). A roomy compartment on each unit is perfect for storing fingerprint taking supplies. Slab and roller cleaner and 100 ink cleaner towelettes are also included.

Specifications	FPT274A	FPT275A
Net Weight	9.1 lbs. (4.13 kg)	11.4 lbs. (5.17 kg)
Dimensions	24 3/4" x 11 1/8" x 9 3/16" (62.9 cm x 28.3 cm x 23.3 cm)	35" x 11 1/8" x 9 3/16" (88.9 cm x 28.3 cm x 23.3 cm)



No. FPT275A

**“Ride the wave with
SIRCHIE®”**

Leading Particulars

- Cabinet Finishes: Vinyl-clad, platinum (gray) and epoxy-painted, black
- Cabinet Material: Aluminum alloy
- Storage Compartment: Dimensioned for standard card storage
- Brackets: Included for optional wall mounting



No. FPT274A

Units consist of:

- 1-No. 230T Fingerprint Ink, Tube, 2 oz.
- 1-No. 233T Slab and Roller Cleaner, 6 oz. aerosol
- 1-No. FPR300 Unified Fingerprint Ink Roller, 3"
- 1-No. FPT254 Ink Cleaner Towelettes, 100 each
- 1-No. FPT258 Ink Slab, Mounted, 4" x 10"
- 1-No. FPT264 Regular Fingerprint Cardholder (FPT274A only)
- 2-No. FPT264 Regular Fingerprint Cardholders (FPT275A only)

CATALOG NO.	INK SLAB AND ROLLER OUTFIT	PRICE
FPT274A	SINGLE CARDHOLDER	\$147.50
FPT275A	DOUBLE CARDHOLDER	\$158.50

FINGERPRINT TAKING AND RECORDING PRODUCTS

PORTABLE FINGERPRINT TAKING OUTFITS

SIRCHIE®'s Portable Fingerprint Taking Outfits combine maximum portability and efficiency. These units feature collapsible legs, which, when opened and placed on a desk or table, achieve regulation height for rolling and recording fingerprints. The Portable Fingerprint Taking Outfits are available with a regular Porelon® fingerprint pad, a STAINFREE™ Porelon® fingerprint pad, an ink slab and roller or the outstanding **PRINTMATIC**™ pre-inked Porelon® roller. Each unit features a mounted cardholder and textured-vinyl leatherette carrying case. These outfits may be easily transported or stored. All outfits are supplied with ink cleaning supplies.

Specifications	PFT500/PFT500S	PFT600	PFT600PIP
Net Weight	16.8 lbs. (7.63 kg)	9.1 lbs. (4.13 kg)	11.2 lbs. (5.08 kg)
Dimensions	24 3/4" x 11 3/8" x 11 1/8" (62.9 cm x 28.9 cm x 28.3 cm)	23 3/4" x 11 3/8" x 11 1/8" (60.3 cm x 28.9 cm x 28.3 cm)	24 3/4" x 12 1/2" x 11 1/8" (62.9 cm x 31.7 cm x 28.3 cm)

Leading Particulars

- Cabinet Finish: Vinyl-clad, platinum and epoxy-painted, black and tan
- Table Material: Aluminum alloy



No. PFT500 With Case Closed



No. PFT500



No. PFT500 With Case Open

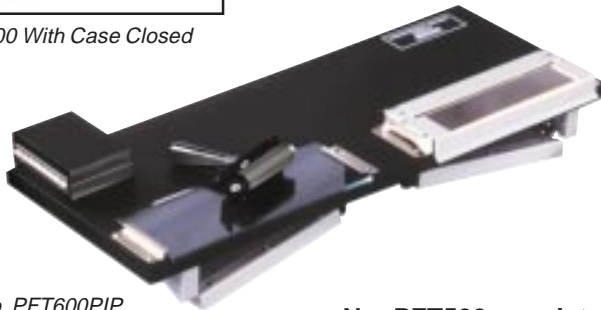

No. PFT600PIP



No. PFT600

No. PFT500 consists of:

- 25- No. FPT2541 Ink Cleaner Towelettes
- 1- No. FPT264 Regular Fingerprint Cardholder
- 1- No. FPT268 Porelon® Fingerprint Pad
- 1- No. FPT268S STAINFREE™ Porelon® Fingerprint Pad (PFT500S only)
- 1- No. PFT5002 Carrying Case, Vinyl-Covered

No. PFT600 consists of:

- 25- No. FPT2541 Ink Cleaner Towelettes
- 1- No. FPT264 Regular Fingerprint Cardholder
- 1- No. 230T Fingerprint Ink, Tube, 2 oz.
- 1- No. 233T Slab and Roller Cleaner, 6 oz. aerosol
- 1- No. FPT258 Ink Slab, Mounted, 4" x 10"
- 1- No. FPR300 Unified Fingerprint Ink Roller, 3"
- 1- No. PFT6002 Carrying Case, Vinyl-Covered

No. PFT600PIP consists of:

- 25- No. FPT2541 Ink Cleaner Towelettes
- 1- No. FPT264 Regular Fingerprint Cardholder
- 1- No. PIP100 **PRINTMATIC**™ Porelon® Fingerprint Ink Roller System
- 1- No. FPT205 Inking Slab, Glass, 4" x 10"
- 1- No. PFT600PIP2 Carrying Case, Vinyl-Covered

CATALOG NO.	DESCRIPTION	PRICE
PFT500	REGULAR PORELON® OUTFIT	\$239.95
PFT500S	STAINFREE™ PORELON® OUTFIT	\$249.95
PFT600	INK SLAB AND ROLLER OUTFIT	\$246.95
PFT600PIP	PRINTMATIC™ PORELON® OUTFIT	\$268.95

PEDESTAL PORELON FINGERPRINT UNITS

SIRCHIE®'s Pedestal Porelon® Fingerprint Units offer the ultimate in appearance and serviceability. Available with one or two cardholder(s), these units feature a regular or STAINFREE™ Porelon® pad. Sturdy and freestanding, these units are versatile because they are not limited to available table or wall space. Each unit features a roomy shelf for storing supplies.

Specifications	FPT200P/FPT200PS	FPT300P/FPT300PS
Net Weight	27.6 lbs. (12.52 kg)	28.9 lbs. (13.11 kg)
Dimensions	23 3/4" x 11 1/8" x 39 1/2" (60.3 cm x 28.3 cm x 100.3 cm)	35" x 11 1/8" x 39 1/2" (88.9 cm x 28.3 cm x 100.3 cm)

Leading Particular

- Cabinet Finish: Vinyl-clad, platinum (gray) and epoxy-painted, black
- Cabinet Material: Aluminum alloy
- Pedestal: Epoxy-painted steel, black-wrinkle finish



No. FPT200P



No. FPT300P

Units consist of:

- 1-No. FPT254 Ink Cleaner Towelettes, 100 each
- 1-No. FPT268 Porelon® Fingerprint Pad (FPT200P and FPT300P only)
- 1-No. FPT268S STAINFREE™ Porelon® Fingerprint Pad (FPT200PS and FPT300PS only)
- 1-No. FPT264 Regular Fingerprint Cardholder (FPT200P only)
- 2-No. FPT264 Regular Fingerprint Cardholder (FPT300P only)

“Ride the wave with SIRCHIE®”

CATALOG NO.	PEDESTAL PORELON® FINGERPRINT UNIT	PRICE
FPT200P	REGULAR PORELON® SINGLE CARDHOLDER	\$253.95
FPT200PS	STAINFREE™ WITH SINGLE CARDHOLDER	\$264.95
FPT300P	REGULAR PORELON® DOUBLE CARDHOLDER	\$263.00
FPT300PS	STAINFREE™ WITH DOUBLE CARDHOLDER	\$274.25

FINGERPRINT TAKING AND RECORDING PRODUCTS

PEDESTAL INK SLAB AND ROLLER FINGERPRINT UNITS

SIRCHIE®'s Pedestal Ink Slab and Roller Fingerprint Units feature a polished, 4" x 10" stainless steel ink slab and are available with one or two cardholder(s). Also, each unit is supplied with a 2-ounce tube of fingerprint ink, a 3" unified fingerprint roller and 100 ink cleaner towelettes. Sturdy and freestanding, these units are built at regulation height for rolling and recording fingerprints. A roomy shelf provides plenty of space for storing supplies.

Specifications	FPT400S	FPT500S
Net Weight	27.6 lbs. (12.52 kg)	29 lbs. (13.15 kg)
Dimensions	24 3/4" x 11 1/8" x 39 1/2" (62.9 cm x 28.3 cm x 100.3 cm)	35" x 11 1/8" x 39 1/2" (88.9 cm x 28.3 cm x 100.3 cm)

Leading Particulars

- Cabinet Finishes: Vinyl-clad, platinum (gray) and epoxy-painted, black
- Cabinet Material: Aluminum alloy
- Pedestal: Epoxy-painted steel, black-wrinkle finish



No. FPT400S



No. FPT500S

Units consist of:

- 1-No. 230T Fingerprint Ink, Tube, 2 oz.
- 1-No. 233T Slab and Roller Cleaner, 6 oz. aerosol
- 1-No. FPR300 Unified Fingerprint Ink Roller, 3"
- 1-No. FPT254 Ink Cleaner Towelettes, 100 each
- 1-No. FPT264 Regular Fingerprint Cardholder (FPT400S only)
- 2-No. FPT264 Regular Fingerprint Cardholders (FPT500S only)
- 1-No. FPT258 Ink Slab, Mounted, 4" x 10"

CATALOG NO.	INK SLAB AND ROLLER UNIT	PRICE
FPT400S	SINGLE CARDHOLDER	\$260.75
FPT500S	DOUBLE CARDHOLDER	\$271.95

PEDESTAL PRINTMATIC™ FINGERPRINT UNITS

SIRCHIE®'s Pedestal **PRINTMATIC™** Fingerprint Units feature the revolutionary **PRINTMATIC™** pre-inked Porelon® ink roller. The **PRINTMATIC™**'s unique design ensures outstanding results—even from inexperienced fingerprint technicians. That's because the **PRINTMATIC™** will automatically roll a thin, uniform layer of ink on the ink slab. These units also feature a 4" x 10" glass ink slab and are supplied with 100 ink cleaner towelettes. Store these and other supplies in the unit's built-in shelf. Available with one or two cardholder(s), these units are built to last.

Specifications	FPT400SPIP	FPT500SPIP
Net Weight	28.8 lbs. (13.04 kg)	30 lbs. (13.61 kg)
Dimensions	24 3/4" x 11 1/8" x 40 1/2" (62.9 cm x 28.3 cm x 102.9 cm)	35" x 11 1/8" x 40 1/2" (88.9 cm x 28.3 cm x 102.9 cm)

Leading Particulars

- Cabinet Finishes: Vinyl-clad, platinum (gray) and epoxy-painted, black
- Cabinet Material: Aluminum alloy
- Pedestal: Epoxy-painted steel, black-wrinkle finish



An operator spreads ink on the Pedestal **PRINTMATIC™** Fingerprint Unit's ink slab with the No. PIP100 **PRINTMATIC™** roller.

“Ride the wave with SIRCHIE®”

No. FPT400SPIP and No. FPT500SPIP consist of:

- 1-No. FPT254 Ink Cleaner Towelettes, 100 each
- 1-No. FPT264 Regular Fingerprint Cardholder (FPT400SPIP only)
- 1-No. FPT205 Inking Slab, Glass, 4" x 10"
- 1-No. PIP100 **PRINTMATIC™** Porelon® Fingerprint Ink Roller System
- 2-No. FPT264 Regular Fingerprint Cardholders (FPT500SPIP only)

CATALOG NO.	PRINTMATIC™ UNIT	PRICE
FPT400SPIP	SINGLE CARDHOLDER	\$282.75
FPT500SPIP	DOUBLE CARDHOLDER	\$293.95

SUPPLEMENTAL FINGERPRINTING TECHNIQUES

about SUPPLEMENTAL FINGERPRINTS

Supplemental fingerprints are commonly referred to as palm prints. As with fingerprints, palm prints provide the investigator with a means of positive identification.

Palm prints are sometimes the only form of latent print evidence at a crime scene. And they're particularly common in burglary cases.

That's because the perpetrator must often place his palms on window sills, case-ments or the top of furniture while forcing entry as well as during the crime.

USE OF PALM PRINTS

Often, the investigator must rely on palm prints—full or partial—for positive identification due to insufficient latent fingerprint evidence.

Palm prints are developed, photographed and lifted in the same manner as fingerprints. As with fingerprints, identification of palm prints is based on comparison of friction ridges and flexure lines. The investigator compares the latent palm prints with those of a suspect in the same manner as fingerprints.

A latent palm print, whether full or partial, offers a great number of minutiae points with which the investigator may compare for positive identification.



This palm print was recorded using the No. AP200 Autopalm printer.

Porelon® Palm Roller



Card Roller

Cover

AP200 AUTOPALM PRINTER

The AP200 Autopalm Printer provides the necessary equipment to roll and record palm prints accurately and quickly. The AP200 utilizes a Porelon® roller (made of the same material as the Porelon® fingerprint pad—impregnated with a two-year supply of ink) that applies a thin, even layer of ink along the contour of the entire palm in one simple motion. A clear impression of the palm, from fingerprints to the wrist, is then recorded on a palm print record card by rolling both over the card roller. The AP200 also may be used for postmortem cases.

The AP200 is lightweight and portable, making it ideal for field use. A sturdy, molded-plastic carrying case is provided with each unit.

Dimensions: Case 16 1/2" x 8 1/2" x 7 1/2"

Weight: 6.5 lbs.

Leading Particulars

- Image Transfer Roller: Soft foam
- Palm Ink Roller: Ink-impregnated Porelon®
- Carrying Case: Molded copolymer with latch

Units consist of:

- 1-No. AP2003 Porelon® Palm Roller (for AP200 only)
- 1-No. AP2003S STAINFREE™ Porelon® Palm Roller (for AP200S only)
- 1-No. AP2004 Image Transfer Roller
- 1-No. AP200CH Palm Roller Recording Mount
- 1-No. AP200PH Palm Roller Inking Mount with Cover
- 8-No. SFL288 Rubber Feet, Adhesive Mount
- 1-No. AP200C Carrying Case



No. AP200 with Carrying Case

CATALOG NO.	DESCRIPTION	PRICE
AP200	REGULAR PORELON® ROLLER	\$139.50
AP200S	STAINFREE™ PORELON® ROLLER	\$159.50

AUTOPALM® PRINT OUTFITS

The AP100 Autopalm® Print Outfits feature all the necessary tools for rolling and recording clear and readable palm prints. These units are self-contained, designed for portable, desktop use. No external ink supply is needed. The Autopalm®'s Porelon® ink roller is designed and precisely positioned on each unit to ink the entire palm with just the right amount of ink. And the unit's soft-foam roller provides the proper surface for recording the print on the palm print record card. The ink roller is impregnated with a two-year supply of ink and is protected by a steel cover when not in use. Both regular and STAINFREE™ palm print rollers are available.

Specifications

AP100/AP100S

Net Weight
Dimensions

17.8 lbs. (8.05 kg)
26 1/2" x 12 3/8" x 9 7/8"
67.3 cm x 31.4 cm x 25.1 cm



No. AP100

Leading Particulars

- Image Transfer Roller: Soft foam
- Palm Ink Roller: Ink-impregnated Porelon®
- Construction: Aluminum alloy and particle board
- Finishes: Vinyl-clad, platinum (gray) and Formica®



A palm is inked on the No. AP100 Autopalm® Print Station's Porelon® ink roller.



The palm print is then recorded on a record card by rolling both on the No. AP100's image transfer roller.

Units consist of:

- 1-No. 236T16 Spray Magic Hand Cleaner, 16 oz. aerosol
- 1-No. AP1001 Porelon® Palm Ink Roller (No. AP100 only)
- 1-No. AP1001S STAINFREE™ Porelon® Palm Ink Roller (No. AP100S only)
- 1-No. AP1002 Image Transfer Roller
- 1-No. FPT254 Ink Cleaner Towelettes, 100 each

“Ride the wave with SIRCHIE®”

CATALOG NO.	DESCRIPTION	PRICE
AP100	REGULAR PORELON® OPTION	\$255.50
AP100S	STAINFREE™ PORELON® OPTION	\$275.50

FINGERPRINT TAKING AND RECORDING PRODUCTS

PORTABLE DESKTOP COMBINATION FINGERPRINT-AUTOPALM® STATIONS

SIRCHIE®'s Portable Desktop Combination Fingerprint-Autopalm® Stations provide the necessary tools for recording both fingerprints and palm prints. Designed for portability, these stations are very durable and built to provide years of dependable service. Each fingerprint-autopalm station features a sliding top. When the top is slid forward and locked, an operator may roll and record fingerprints. When the top is unlocked and pushed to the rear, the operator has access to the palm printing supplies. The fingerprint-autopalm stations are available with a regular Porelon® pad, a STAINFREE™ Porelon® pad, an ink slab and roller or a **PRINTMATIC™** pre-inked Porelon®. Each unit also is supplied with a Porelon® palm roller and image transfer roller for recording palm prints.

Specifications	APC200/APC200S	APC300/APC300S	APC300PIP
Net Weight	27.7 lbs. (12.66 kg)	27.9 lbs. (12.66 kg)	29.7 lbs. (13.47 kg)
Dimensions	26 1/2" x 13 3/4" x 11 5/8" (67.3 cm x 34.9 cm x 29.5 cm)	26 1/2" x 13 3/4" x 11 5/8" (67.3 cm x 34.9 cm x 29.5 cm)	26 1/2" x 13 3/4" x 12 1/2" (67.3 cm x 34.9 cm x 31.7 cm)

Leading Particulars

- Cabinet Finishes: Vinyl-clad, platinum (gray) and Formica®
- Cabinet Materials: Aluminum alloy and Formica®-covered hardboard
- Image Transfer Roller: Soft foam
- Palm Ink Roller: Impregnated Porelon®
- Sliding Top: Locks into place for fingerprinting slides away for palm printing



No. APC300
Slab and Roller Option

No. APC300 consists of:

- 1-No. 230T Fingerprint Ink, Tube, 2 oz.
- 1-No. 233T Slab and Roller Cleaner, 6 oz. aerosol
- 1-No. 236T16 Spray Magic Hand Cleaner, 16 oz. aerosol
- 1-No. FPR300 Unified Fingerprint Ink Roller, 3"
- 1-No. FPT258 Ink Slab, Mounted, 4" x 10"
- 1-No. FPT254 Ink Cleaner Towelettes, 100 each
- 1-No. FPT264 Regular Fingerprint Cardholder
- 1-No. AP1001 Porelon® Palm Ink Roller
- 1-No. AP1002 Image Transfer Roller

CONTINUE





No. APC200 Regular Porelon® Option

No. APC200 consists of:

- 1-No. 236T16 Spray Magic Hand Cleaner, 16 oz. aerosol
- 1-No. FPT268 Porelon® Fingerprint Pad (APC200 only)
- 1-No. FPT268S STAINFREE™ Porelon® Fingerprint Pad (APC200S only)
- 1-No. FPT254 Ink Cleaner Towelettes, 100 each
- 1-No. FPT264 Regular Fingerprint Cardholder
- 1-No. AP1001 Porelon® Palm Ink Roller (APC200 only)
- 1-No. AP1001S STAINFREE™ Porelon Ink Roller (APC200S only)
- 1-No. AP1002 Image Transfer Roller

**“Ride the wave with
SIRCHIE®”**



No. APC300PIP PRINTMATIC™ Option

No. APC300PIP consists of:

- 1-No. 236T16 Spray Magic Hand Cleaner, 16 oz. aerosol
- 1-No. FPT205 Inking Slab, Glass, 4" x 10"
- 1-No. PIP100 PRINTMATIC™ Porelon® Fingerprint Ink Roller System
- 1-No. FPT254 Ink Cleaner Towelettes, 100 each
- 1-No. FPT264 Regular Fingerprint Cardholder
- 1-No. AP1001 Porelon® Palm Ink Roller
- 1-No. AP1002 Image Transfer Roller

CATALOG NO.	DESCRIPTION	PRICE
APC200	REGULAR PORELON® STATION	\$320.50
APC300	INK SLAB AND ROLLER STATION	\$330.95
APC300PIP	PRINTMATIC™ STATION	\$360.95
APC200S	STAINFREE™ STATION	\$365.50

FINGERPRINT TAKING AND RECORDING PRODUCTS

COMBINATION FINGERPRINT-AUTOPALM® PRINT STATIONS

SIRCHIE®'s Combination Fingerprint-Autopalm® Print Stations are just what the name implies—pedestal-mounted fingerprint and palm print stations. These sturdy, freestanding stations are built at regulation height for rolling and recording both fingerprints and palm prints. They feature a sliding top which may be locked into position for fingerprint recording and unlocked and slid back for access to the palm printing supplies. The stations are available with a regular Porelon® pad, a STAINFREE™ Porelon® pad, an ink slab and roller or a **PRINTMATIC™** pre-inked Porelon® roller. Each is equipped with a Porelon® palm roller and palm card roller. Also, a storage area is provided behind the palm card roller for keeping record cards as well as other supplies.

Specifications	CFPS100/CFPS100S	CFPS200	CFPS200PIP
Net Weight	46.1 lb. (20.91 kg)	46.2 lb. (20.96 kg)	48.1 lb. (21.82 kg)
Dimensions	26 1/2" x 13 3/4" x 42" (67.3 cm x 34.9 cm x 106.7 cm)	26 1/2" x 13 3/4" x 42" (67.3 cm x 34.9 cm x 106.7 cm)	26 1/2" x 13 3/4" x 42 7/8" (67.3 cm x 34.9 cm x 108.9 cm)

Leading Particulars

- Cabinet Finishes: Vinyl-clad, platinum (gray) and gray
- Cabinet Materials: Aluminum alloy and laminated hardboard
- Pedestal: Epoxy-painted steel, black wrinkle
- Image Transfer Roller: Soft foam
- Palm Ink Roller: Ink-impregnated Porelon®
- Locking Bench Top: Slides back for convenient access to palm station accessories



No. CFPS100
Porelon® Option

No. CFPS100 consists of:

- 1-No. 236T16 Spray Magic Hand Cleaner, 16 oz. aerosol
- 1-No. AP1001 Porelon® Palm Ink Roller (CFPS100 only)
- 1-No. AP1002 Image Transfer Roller
- 1-No. AP1001S STAINFREE™ Porelon® Palm Ink Roller (CFPS100S only)
- 1-No. FPT254 Ink Cleaner Towelettes, 100 each
- 1-No. FPT264 Regular Fingerprint Cardholder
- 1-No. FPT268 Porelon® Fingerprint Pad (CFPS100 only)
- 1-No. FPT268S STAINFREE™ Porelon® Fingerprint Pad (CFPS100S only)

CONTINUE



No. CFPS200PIP consists of:

- 1-No. 236T16 Spray Magic Hand Cleaner, 16 oz. aerosol
- 1-No. AP1001 Porelon® Palm Ink Roller
- 1-No. AP1002 Image Transfer Roller
- 1-No. FPT205 Inking Slab, Glass, 4" x 10"
- 1-No. FPT254 Ink Cleaner Towelettes, 100 each
- 1-No. FPT264 Regular Fingerprint Cardholder
- 1-No. PIP100 **PRINTMATIC™** Porelon® Fingerprint Ink Roller System



*No. CFPS200PIP
PRINTMATIC™ Option*



*No. CFPS200
Slab and Roller Option*

**“Ride the wave with
SIRCHIE®”**

No. CFPS200 consists of:

- 1-No. 230T Fingerprint Ink, Tube, 2 oz.
- 1-No. 233T Slab and Roller Cleaner, 6 oz. aerosol
- 1-No. 236T16 Spray Magic Hand Cleaner, 16 oz. aerosol
- 1-No. AP1001 Porelon® Palm Ink Roller
- 1-No. AP1002 Image Transfer Roller
- 1-No. FPR300 Unified Fingerprint Ink Roller, 3"
- 1-No. FPT254 Ink Cleaner Towelettes, 100 each
- 1-No. FPT264 Regular Fingerprint Cardholder
- 1-No. FPT258 Ink Slab, Mounted, 4" x 10"

CATALOG NO.	COMBINATION AUTOPALM® PRINT STATION	PRICE
CFPS100	REGULAR PORELON® OPTION	\$440.50
CFPS200	INK SLAB AND ROLLER OPTION	\$475.00
CFPS200PIP	PRINTMATIC™ OPTION	\$495.95
CFPS100S	STAINFREE™ PORELON® OPTION	\$499.50

FINGERPRINT TAKING AND RECORDING PRODUCTS

COMPACT FOLDING FINGERPRINT TAKING KITS

SIRCHIE's Compact Folding Fingerprint Taking Kits are among the most popular of their kind available. When opened, these kits convert any desk or tabletop into efficient fingerprint taking stations. They are ideal choices whenever maximum portability is required. The kits are available with a regular Porelon® pad, a STAINFREE™ Porelon® pad, an ink slab and roller or a **PRINTMATIC™** pre-inked Porelon® roller.



No. CFP500A

No. CFP500A consists of:

- 1- No. FEL101K Fingerprint Cardholder
- 20- No. FPT2541 Ink Cleaner Towelettes
- 1- No. FPT268 Porelon® Fingerprint Pad (CFP500A only)
- 1- No. FPT268S STAINFREE™ Porelon® Fingerprint Pad (CFP500AS only)
- 1- No. KCP152 Accessory Case, Polypropylene
- 1- No. CFP500A1 Carrying Case, Vinyl-Leatherette Covered

No. CFP600A consists of:

- 1- No. 230T Fingerprint Ink, Tube, 2 oz.
- 1- No. 233T Slab and Roller Cleaner, 6 oz. aerosol
- 1- No. FEL101K Fingerprint Cardholder
- 1- No. FPT262A Fingerprint Ink Roller, 3"
- 20- No. FPT2541 Ink Cleaner Towelettes
- 1- No. FPT258 Ink Slab, Mounted, 4" x 10"
- 1- No. KCP152 Accessory Case, Polypropylene
- 1- No. CFP600A1 Carrying Case, Vinyl-Leatherette Covered

No. CFP600APIP consists of:

- 1- No. FEL101K Fingerprint Cardholder
- 1- No. FPT205 Inking Slab, Glass, 4" x 10"
- 20- No. FPT2541 Ink Cleaner Towelettes
- 1- No. PIP100H **PRINTMATIC™** Horizontal Porelon® Fingerprint Ink Roller System
- 1- No. CFP600A1PIP Carrying Case, Vinyl-Leatherette Covered
- 1- No. KCP152 Accessory Case, Polypropylene



This is a closed Compact Folding Fingerprint Taking Kit.

CATALOG NO.	COMPACT FOLDING KIT	PRICE
CFP500A.....	REGULAR PORELON® OPTION	\$119.50
CFP600A.....	INK SLAB AND ROLLER OPTION	\$123.95
CFP600APIP	PRINTMATIC™ OPTION	\$145.95
CFP500AS	STAINFREE™ PORELON® OPTION	\$129.50

COMPACT FOLDING TAKING AND LIFTING KITS

These kits are ideal for both fingerprint taking and latent print dusting. They're lightweight, compact and perfect for field use. Kits are available with a regular Porelon® pad, a STAINFREE™ Porelon® pad, a slab and roller or a PRINTMATIC™ pre-inked roller, and each comes with many of the most commonly used latent print dusting and lifting supplies.

Specifications	CFP700A/CFP700AS	CFP800A
Net Weight	9.6 lbs. (4.35 kg)	9.6 lbs. (4.35 kg)
Dimensions	13" x 13" x 6" (33 cm x 33 cm x 15.2 cm)	13" x 13" x 6" (33 cm x 33 cm x 15.2 cm)



No. CFP700A

Units consist of:

- 1- No. FEL101K Fingerprint Cardholder
- 20- No. FPT2541 Ink Cleaner Towelettes
- 1- No. 101L1 HI-FI Volcano Latent Print Powder, Silk Black, 1 oz.
- 1- No. 103L1 HI-FI Volcano Latent Print Powder, Indestructible White, 1 oz.
- 2- No. 118L Regular Powder Brush
- 1- No. 145L2 Fingerprint Lifting Tape, Frosted, 2" x 360"
- 1- No. FPT268 Porelon® Fingerprint Pad (CFP700A only)
- 1- No. FPT268S STAINFREE™ Porelon® Fingerprint Pad (CFP700AS only)
- 1- No. FPT262A Fingerprint Ink Roller, 3" (CFP800A only)
- 1- No. FPT258 Ink Slab, Mounted, 4" x 10" (CFP800A only)
- 1- No. 230T Fingerprint Ink, Tube, 2 oz. (CFP800A only)
- 1- No. 233T Slab and Roller Cleaner, 6 oz. aerosol (CFP800A only)
- 1- No. LB0021 Lifted Print Backing Sheet Pad, Gloss Black Reversible
- 1- No. KCP152 Accessory Case, Polypropylene
- 1- No. PIP100H PRINTMATIC™ Porelon® Fingerprint Ink Roller System (CFP800APIP only)
- 1- No. CFP700A1 Carrying Case, Vinyl Leatherette Covered (CFP700A/CFP700AS only)
- 1- No. CFP800A1 Carrying Case, Vinyl Leatherette Covered (CFP800A only)

**“Ride the wave with
SIRCHIE®”**

CATALOG NO.	COMPACT FOLDING COMBINATION KIT	PRICE
CFP700A	PORELON®	\$129.50
CFP700AS	STAINFREE™ PORELON®	\$138.50
CFP800A	INK SLAB AND ROLLER	\$123.95
CFP800APIP	PRINTMATIC™ OPTION	\$148.50

FINGERPRINT TAKING AND RECORDING PRODUCTS

CRIME SCENE FINGERPRINT ELIMINATION KIT

The Crime Scene Fingerprint Elimination Kit is designed for differentiating between the latent prints of those who have regular access to a crime scene and unknown latent prints. This eliminates unnecessary comparison of known latent prints with those on file. Each kit includes a Porelon® fingerprint pad, elimination fingerprint forms and ink cleaner towelettes in a compact, simulated-leather case. Kits are available with a regular or STAINFREE™ Porelon® pad. Dimensions: 9 1/2" x 4 1/2" x 2 1/4". Weight: 16 oz. (0.45 kg).

Leading Particulars

- Case: Simulated leather
- Ink Pad: Pocket model Porelon® fingerprint pad

No. EFP90 consists of:

- 24 - No. FPT2541 Ink Cleaner Towelettes
- 1 - No. FPT267 Porelon® Fingerprint Pad (EFP90 only)
- 1 - No. FPT267S STAINFREE™ Porelon® Fingerprint Pad (EFP90S only)
- 1 - No. FPT270A Elimination Pad, 50 sheet
- 1 - No. FPT2701 Wallet-Type Vinyl Case
- 1 - No. EFP901 Zipper-Type Simulated Leather Carrying Case



CATALOG NO.	KIT	PRICE
EFP90	REGULAR PORELON® KIT	\$47.25
EFP90S	STAINFREE™ PORELON® KIT	\$57.25

ELIMINATION FINGERPRINT OUTFIT

This convenient outfit fits nicely in a coat pocket. As with the kit pictured above, it is designed for differentiating between the latent prints of those who have regular access to a crime scene and unknown latent prints. Each outfit is supplied with a replaceable notebook that contains 50 printed fingerprint forms. Record the subject's fingerprints on the front of the form and the date and other information on the back. Kits are available with a regular Porelon® pad or a STAINFREE™ Porelon® pad. Dimensions of the kit are: 7 3/8" x 3 1/2" x 1".



No. FPT270 consists of:

- 1-No. FPT267 Porelon® Fingerprint Pad (FPT270 only)
- 1-No. FPT267S STAINFREE™ Fingerprint Pad (FPT270 only)
- 1-No. FPT270A Elimination Pad, 50 sheet
- 1-No. FPT2701 Wallet-Type Vinyl Case

CATALOG NO.	DESCRIPTION	PRICE
FPT270	REGULAR PORELON® OUTFIT	\$29.75
FPT270S	STAINFREE™ PORELON® OUTFIT	\$40.75
FPT270A	ELIMINATION PAD ONLY, 50 SHEET	\$5.50

FIELD FINGERPRINT TAKING KITS

This compact kit is ideal for taking field fingerprints. Included are a pocket Porelon® pad and one fingerprint record cardholder. The contents of this portable outfit are fitted into an attractive, textured, copolymer-molded carrying case. STAINFREE™ and PRINTMATIC™ options are available.

Specifications	FPT100/FPT100S	FPT200	FPT200PIP
Net Weight	4.5 lbs. (2.04 kg)	4.5 lbs. (2.04 kg)	5.4 lbs. (2.45 kg)
Dimensions	14 1/2" x 7 13/16" x 7" (36.8 cm x 19.8 cm x 17.8 cm)	14 1/2" x 7 13/16" x 7" (36.8 cm x 19.8 cm x 17.8 cm)	14 1/2" x 7 13/16" x 7" (36.8 cm x 19.8 cm x 17.8 cm)

No. FPT100



No. FPT100 and No. FPT100S consist of:

- 1- No. FEL101N Super Fingerprint Cardholder, with Non-Slip Base
- 50- No. FPT2541 Ink Cleaner Towelettes
- 1- No. FPT267 Porelon® Fingerprint Pad (FPT100 only)
- 1- No. FPT267S STAINFREE™ Porelon® Fingerprint Pad (FPT100S only)
- 1- No. KCP152 Accessory Case, Polypropylene
- 1- No. FPT1001 Molded Copolymer Carrying Case with Latch

No. FPT200 consists of:

- 1- No. 230T Fingerprint Ink, Tube, 2 oz.
- 1- No. FEL101N Super Fingerprint Cardholder, with Non-Slip Base
- 1- No. FPT205 Inking Slab, Glass, 4" x 10"
- 50- No. FPT2541 Ink Cleaner Towelettes
- 1- No. FPR200 Unified Fingerprint Ink Roller, 2"
- 1- No. KCP152 Accessory Case, Polypropylene
- 1- No. FPT2001 Molded Copolymer Carrying Case with Latch

No. FPT200PIP consists of:

- 1- No. FEL101N Super Fingerprint Cardholder with Non-Slip Base
- 1- No. FPT205 Inking Slab, Glass, 4" x 10"
- 50- No. FPT2541 Ink Cleaner Towelettes
- 1- No. PIP100H PRINTMATIC™ Porelon® Fingerprint Ink Roller System
- 1- No. FPT2001PIP Molded Copolymer Carrying Case with Latch
- 1- No. KCP152 Accessory Case, Polypropylene

CATALOG NO.	DESCRIPTION	PRICE
NO. FPT100	REGULAR PORELON® KIT	\$55.50
NO. FPT100S	STAINFREE™ PORELON® KIT	\$65.50
NO. FPT200	INK SLAB AND ROLLER KIT	\$60.95
NO. FPT200PIP	PRINTMATIC™ OPTION KIT	\$82.50

FINGERPRINT TAKING AND RECORDING PRODUCTS

POSTMORTEM INKING TOOLS

Designed specifically for taking fingerprints of the deceased, these finger-sized, pre-inked Porelon® pads greatly simplify the task of inking immobilized fingers. They permit rapid, efficient and uniform finger inking. A rugged, anodized-aluminum case assures years of service. Pad elements are easily replaceable. Dimensions: 6" x 1 13/16" x 1/2". Weight: 2.8 oz. (80 g).

Leading Particulars

- Material: Brushed, nickel-plated steel
- Cover: Slide-on friction fit

No. PM283 with cover removed

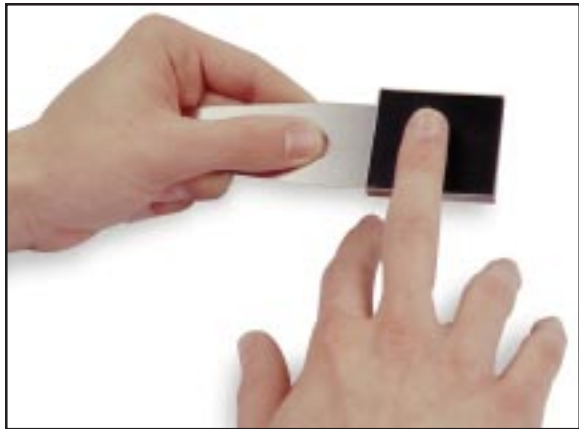
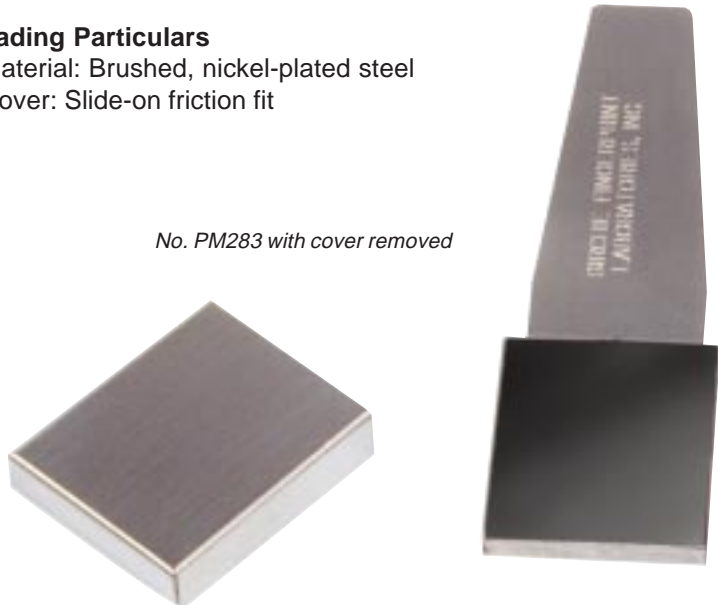

An operator inks a finger with the No. PM283 Postmortem Inking Tool prior to recording print.

CATALOG NO.	DESCRIPTION	PRICE
PM283	PORELON® POSTMORTEM INKING TOOL	\$18.95
PM283P	REPLACEMENT PAD (ONLY) (FOR PM283)	\$9.95

POSTMORTEM RECORD STRIP HOLDER

This no-smudge, postmortem record strip holder is designed to hold FC345 or FC543 card strips (see page 42) for successful fingerprinting of the deceased. Dimensions: 5 3/4" x 1 1/2" x 3/4". Weight: 2 oz. (57 g).

Leading Particulars

- Material: Cold-rolled steel
- Finish: Vinyl-clad aluminum black



No. PMNS60

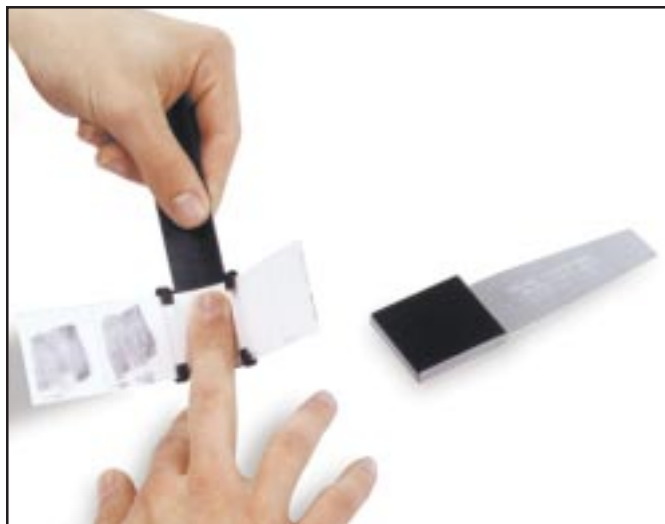

An operator records prints with the No. PMNS60 Record Strip Holder.

CATALOG NO. PMNS60	HOLDER	PRICE: \$14.25
--------------------------	--------------	----------------

POSTMORTEM FINGER STRAIGHTENERS

These postmortem tools are specially designed to straighten clenched fingers of the deceased. Each of three tools feature two different-sized hole openings to accommodate the vast majority of finger sizes. Tools are made of zinc-plated steel and are supplied in a convenient carrying pouch. Weight—Tools and Case: 6 oz.



Use the Postmortem Finger Straighteners to straighten clenched fingers of the deceased.



Leading Particulars

- Hole Sizes: 7/16", 1/2", 9/16", 5/8", 11/16", and 3/4"
- Material: Bright zinc plated steel
- Pouch: Heavy nylon duck

CATALOG NO. PMFS500 COMPLETE KIT PRICE: \$21.95

FOLDING POSTMORTEM HOLDER

This revolutionary-designed folding postmortem record strip holder is designed to hold the FC345 or FC543 card strips while allowing for perfect impressions. The curvature of the PMNS60B allows for ease of operation and reduces the chance of smudges.



The No. PMNS60B is pictured closed.



The No. PMNS60B is pictured with a card being loaded into the holder.



Leading Particulars

- Material: .031" thick brushed nickeloid finish
- Length: 5 3/4"
- Deep: 7/8"
- Width: 1 1/4"
- New folding option allows for optimum workability
- Deeper printing area for added detail
- Easy loading and unloading of record strip



CATALOG NO.	DESCRIPTION	PRICE
PMNS60B	FOLDING POSTMORTEM HOLDER	\$24.95

FINGERPRINT TAKING AND RECORDING PRODUCTS

BASIC POSTMORTEM FINGERPRINT KIT

This kit contains all the necessary components for the fingerprinting of the deceased prior to the onset of rigor mortis. It is also useful for fingerprinting the infirm. Ink cleaning towelettes are included, making this a complete kit. This kit is housed in a professional, simulated-leather case with zipper. This kit does NOT contain finger straighteners. Dimensions: 9 1/2" x 4 1/2" x 1 1/4". Weight: 0.8 lbs. (0.35 kg).



No. PMFT01 consists of:

- 12- No. FC345L1 Postmortem Record Strip, Left Hand, Standard
- 12- No. FC345R1 Postmortem Record Strip, Right Hand, Standard
- 1- No. PM283 Postmortem Inking Tool (PMFT01 only)
- 1- No. PM283S STAINFREE™ Postmortem Inking Tool (PMFT01S only)
- 12- No. FPT2541 Ink Cleaner Towelettes
- 1- No. PMNS60 Postmortem Record Strip Holder
- 1- No. PMFT011 Zipper-Type Simulated Leather Carrying Case

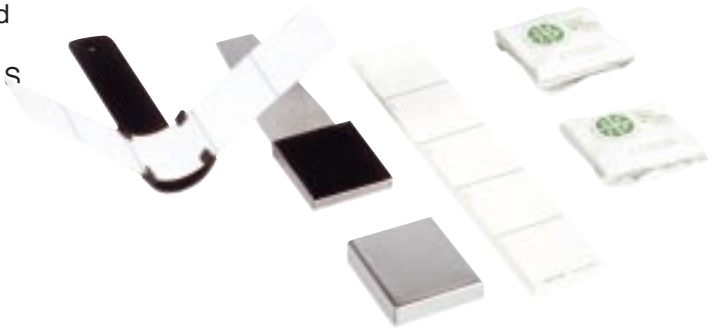

CATALOG NO.	DESCRIPTION	PRICE
PMFT01	REGULAR PORELON® POSTMORTEM KIT	\$43.50
PMFT01S	STAINFREE™ PORELON® POSTMORTEM KIT	\$48.50



DELUXE POSTMORTEM FINGERPRINT KIT

This is a complete kit containing all the necessary components needed for fingerprinting the deceased and infirm. It includes a set of finger straighteners, as well as a Porelon® postmortem inking tool, a postmortem record strip holder and a handy carrying case. Kit is available with a regular Porelon® pad or a STAINFREE™ Porelon® pad.

No. PMFT02 consists of:

- 12- No. FC345L1 Postmortem Record Strip, Left Hand, Standard
- 12- No. FC345R1 Postmortem Record Strip, Right Hand, Standard
- 12- No. FPT2541 Ink Cleaner Towelettes
- 1- No. PM283 Postmortem Inking Tool (PMFT02 only)
- 1- No. PM283S STAINFREE™ Postmortem Inking Tool (PMFT02S only)
- 1- No. PMFS500 Postmortem Finger Straighteners
- 1- No. PMNS60 Postmortem Record Strip Holder
- 1- No. PMFT011 Zipper-Type Simulated Leather Carrying Case



CATALOG NO.	DESCRIPTION	PRICE
PMFT02	REGULAR PORELON® POSTMORTEM KIT	\$54.50
PMFT02S	STAINFREE™ PORELON® POSTMORTEM KIT	\$59.50

FINGER SOFTENING KIT

This is a complete kit for rendering the finger tissue of a deceased person sufficiently pliable for successful fingerprinting. Reagents, a bone cutter and ten labeled plastic vials are included in this kit. Weight: 11 lbs. (4.99 kg). Dimensions: 17 1/2" x 10 3/16" x 8 7/8" (44.4 cm x 25.9 cm x 22.5 cm).

No. FS200 consists of:

- 1-No. AEC202 Bone Cutter, 5"
- 1-No. FS002 Finger Softening Solution A, 1 pint
- 1-No. FS003 Finger Softening Solution B, 1 pint
- 1-No. FS004 Finger Softening Solution C, 1 pint
- 1-No. FS005 Finger Softening Solution D, 1 pint
- 1-No. KCP111 Scissors, Dissection with Curved Blades
- 2-No. KCP138 Disposable Scalpels, 5"
- 1-No. KCP180 Vial Polystyrene, 2 oz. with Cap Labeled "Right Thumb"
- 1-No. KCP181 Vial Polystyrene, 2 oz. with Cap Labeled "Right Index Finger"
- 1-No. KCP182 Vial Polystyrene, 2 oz. with Cap Labeled "Right Middle Finger"
- 1-No. KCP183 Vial Polystyrene, 2 oz. with Cap Labeled "Right Ring Finger"
- 1-No. KCP184 Vial Polystyrene, 2 oz. with Cap Labeled "Right Little Finger"
- 1-No. KCP185 Vial Polystyrene, 2 oz. with Cap Labeled "Left Thumb"
- 1-No. KCP186 Vial Polystyrene, 2 oz. with Cap Labeled "Left Index Finger"
- 1-No. KCP187 Vial Polystyrene, 2 oz. with Cap Labeled "Left Middle Finger"
- 1-No. KCP188 Vial Polystyrene, 2 oz. with Cap Labeled "Left Ring Finger"
- 1-No. KCP189 Vial Polystyrene, 2 oz. with Cap Labeled "Left Little Finger"
- 1-No. KCP190 Filter Paper, 2 1/2" dia. disc, 12 each
- 1-No. SF00771 Disposable Latex Gloves, pair
- 1-No. FS2001 Molded Copolymer Carrying Case with Latch



CATALOG NO. FS200 FINGER SOFTENING KIT PRICE: \$193.95

CADAVER TAKING KIT COMBINATION

This kit contains the essential reagents and hardware for postmortem fingerprint treatment and restoration. The tissue builder solution is packaged in disposable vials for convenience. A postmortem inking tool and record strips are included for recording prints after treatment. Dimensions: 13 1/2" x 10 1/2" x 5" (34.3 cm x 26.7 cm x 12.7 cm). Weight: 6.5 lbs. (2.95 kg).

No. CTK100 consists of:

- 12- No. FC345L1 Postmortem Record Strips, Left Hand, Standard
- 12- No. FC345R1 Postmortem Record Strips, Right Hand, Standard
- 10- No. FPT2541 Ink Cleaner Towelettes
- 4- No. KCP148 Syringe, 3 cc, Disposable
- 15- No. KCP217 Cotton Balls
- 8- No. KRL103D Tissue Builder Solution, 1/2 oz.
- 2- No. KRL1052 Finger Tissue Cleaner, 2 oz.
- 1- No. KRL1062 Tissue Builder Solvent, 2 oz.
- 1- No. PM283 Postmortem Inking Tool
- 1- No. PMNS60 Postmortem Record Strip Holder
- 1- No. SF00771 Disposable Latex Gloves, pair
- 1- No. CTK1001 Carrying Case, Leatherette-Covered



CATALOG NO. CTK100 KIT COMBINATION PRICE: \$97.50

FIELD AND LAB DISASTER KIT



The Field and Lab Disaster Kit is a complete postmortem investigative kit. It includes reagents and supplies necessary for rendering fingers of the deceased sufficiently pliable for fingerprinting. It also includes an anti-putrefaction mask and spare filters. Dimensions: 20 13/16" x 13" x 10" (52.9 cm x 33 cm x 25.4 cm).



No. FLD100 consists of:

- 1- No. 603E Evidence Identification Tape, 1" x 500"
- 1- No. AEC202 Bone Cutter, 5"
- 2- No. FS002 Finger Softening Solution A, 1 pint
- 2- No. FS003 Finger Softening Solution B, 1 pint
- 1- No. FS004 Finger Softening Solution C, 1 pint
- 1- No. FS005 Finger Softening Solution D, 1 pint
- 1- No. KCP111 Scissors, Dissecting with curved blades
- 4- No. KCP138 Disposable Scalpels, 5"
- 2- No. KCP148 Syringe, 3 cc Disposable
- 1- No. PM283 Postmortem Inking Tool
- 12- No. FPT2541 Ink Cleaner Towelettes
- 1- No. PMNS60 Postmortem Record Strip Holder
- 1- No. PU005 Anti-Putrefaction Mask
- 1- No. SF00771 Disposable Latex Gloves, pair
- 1- No. PU006 Replacement Filter for Anti-Putrefaction Mask
- 12- No. FC345L1 Postmortem Record Strip, Left Hand, Standard
- 12- No. FC345R1 Postmortem Record Strip, Right Hand, Standard
- 1- No. KCP180 2 oz. Polystyrene Vial, w/label "Right Thumb"
- 1- No. KCP181 2 oz. Polystyrene Vial, w/label "Right Index Finger"
- 1- No. KCP182 2 oz. Polystyrene Vial, w/label "Right Middle Finger"
- 1- No. KCP183 2 oz. Polystyrene Vial, w/label "Right Ring Finger"
- 1- No. KCP184 2 oz. Polystyrene Vial, w/ label "Right Little Finger"
- 1- No. KCP185 2 oz. Polystyrene Vial, w/label "Left Thumb"
- 1- No. KCP186 2 oz. Polystyrene Vial, w/ label "Left Index Finger"
- 1- No. KCP187 2 oz. Polystyrene Vial, w/label "Left Middle Finger"
- 1- No. KCP188 2 oz. Polystyrene Vial, w/label "Left Ring Finger"
- 1- No. KCP189 2 oz. Polystyrene Vial, w/label "Left Little Finger"
- 1- No. KCP190 Filter Paper, 2 1/2" dia. disc, 12 each
- 15- No. KCP217 Cotton Balls
- 8- No. KRL103D Tissue Builder Solution, 1/2 oz.
- 1- No. KRL1052 Finger Tissue Cleaner, 2 oz.
- 1- No. KRL1062 Tissue Builder Solvent, 2 oz.
- 1- No. FLD1001C Carrying Case, 20 13/16" x 13" x 10" Leatherette-Finish with Plastic Inserts

CATALOG NO. FLD100..... PRICE: \$393.50

STANDARD PALM PRINT RECORD CARDS

SIRCHIE®'s standard 8" x 8" format palm print record cards are printed on the best 110-pound index card stock and are used by identification departments across the globe. If ordering 5,000 or more cards, the department's name may be printed on the cards at no extra charge. Please specify when ordering.

CATALOG NO.	STANDARD PALM PRINT CARDS	PRICE
AP110.....	100 EACH.....	\$16.95
AP110M.....	1,000 EACH.....	\$115.00
AP110M5.....	5,000 EACH.....	\$360.00



DIAGONAL PALM PRINT RECORD CARDS

These standard 8" x 8" cards feature a diagonal design for recording palm prints. Printed on the best quality 110-pound index card stock, they are used by identification departments around the world. If ordering 5,000 or more cards, the department's name may be printed on the cards at no extra charge. Please specify when ordering.

CATALOG NO.	DIAGONAL PALM PRINT CARDS	PRICE
AP112.....	100 EACH.....	\$16.95
AP112M.....	1,000 EACH.....	\$115.00
AP112M5.....	5,000 EACH.....	\$360.00

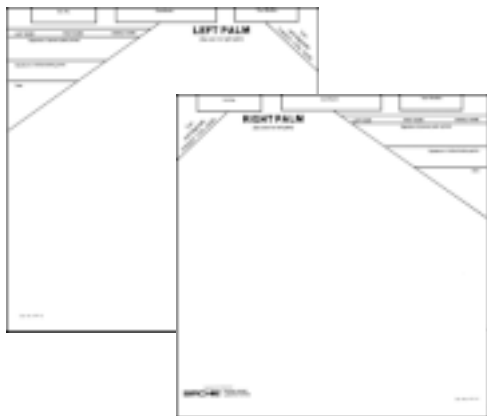

CRIMINAL RECORD CARDS

These standard 8" x 8" format criminal record cards feature a balance of a super-smooth, brilliant white finish and fast-ink absorption. Printed on tough, 110-pound index card stock, they are flexible enough so that typewriters will not crease or wrinkle them. Cards are printed with non-fading ink. If ordering 5,000 or more, the department's name may be printed on the cards at no extra charge. Specify when ordering.

CATALOG NO.	CRIMINAL RECORD CARDS	PRICE
FC330.....	100 EACH.....	\$16.95
FC330M.....	1,000 EACH.....	\$115.00
FC330M5.....	5,000 EACH.....	\$360.00



APPLICANT RECORD CARDS

These 8" x 8" format record cards are printed in process blue on the best 110-lb. index card stock. Designed to the specifications of the U.S. Immigration and Naturalization Service, they are available with or without a custom ORI number.

CATALOG NO.	APPLICANT RECORD CARDS	PRICE
FD258.....	100 EACH.....	\$19.95
FD2585.....	500 EACH.....	\$66.78
FD258M.....	1,000 EACH.....	\$119.15
FD258S.....	CARDS W/IMPRINT, 500 EACH.....	\$137.12
FD258SM.....	CARDS W/IMPRINT, 1,000 EACH.....	\$219.80
FD258SM5.....	CARDS W/IMPRINT, 5,000 EACH.....	\$497.00



FINGERPRINT TAKING AND RECORDING PRODUCTS



No. FC332 Tip Print Card



No. FC332P Palm Print Card

MAJOR CASE AND TIP PRINT CARDS

Major case cards should be utilized on robbery suspects, as well as sexual assault, homicide and burglary suspects because latent prints recovered from crime scenes may include palms, finger tips and finger joints. The FC332 is a two-card system that allows for easy storage in a conventional 8" x 8" record card file. The 8" x 16" forms are printed on the best 110-pound index card stock with a fold line in the middle. There is a form on the front of each card for recording the inked impressions. There are detailed instructions on the back of each card describing how to record the impressions and there is an area to record the suspect's personal information. The FC332 consists of 50 sets of palm print cards and tip print cards. These cards supplement standard 8" x 8" record cards.

CAT. NO.	DESCRIPTION	PRICE
FC332	MAJOR CASE CARDS, 50 SETS	\$19.95
FC3325	MAJOR CASE CARDS, 250 SETS	\$67.50

POSTMORTEM RECORD STRIPS

These unique record strips are designed specifically for use with the **SIRCHIE**® PMNS60 Postmortem Record Strip Holder. They are offered in two forms. The Standard Record Strips feature a white finish and absorb ink rapidly. Made from 110 lb. index card stock, they are an exact match to standard 8" x 8" fingerprint record cards. The Adhesive-Backed Record Strips also feature a white finish and absorb ink rapidly. Their crack-and-peel adhesive backing adheres easily to standard 8" x 8" fingerprint record cards. Dimensions—all strips: 8" x 1 1/2" (20.3 cm x 3.8 cm).

Standard and Crack-and-Peel Record Strips



CATALOG NO.	POSTMORTEM RECORD STRIP	PRICE
FC345L	LEFT HAND, STANDARD, 100 EACH	\$10.75
FC345L5	LEFT HAND, STANDARD, 500 EACH	\$44.75
FC345R	RIGHT HAND, STANDARD, 100 EACH	\$10.75
FC345R5	RIGHT HAND, STANDARD, 500 EACH	\$44.75
FC543L	LEFT HAND, ADHESIVE BACKED, 100 EACH	\$12.25
FC543L5	LEFT HAND, ADHESIVE BACKED, 500 EACH	\$46.50
FC543R	RIGHT HAND, ADHESIVE BACKED, 100 EACH	\$12.25
FC543R5	RIGHT HAND, ADHESIVE BACKED, 500 EACH	\$46.50



PERSONAL RECORD CARDS

These 8" x 8" record cards are intended for noncriminal applications. They are printed with non-fading ink on tough, 110-pound index card stock. They're ideal for law enforcement personnel records, as well as for use in other settings such as hospitals, security agencies, banks and schools. Order 5,000 or more cards, and the department or agency's name may be printed on them at no extra charge. Please specify when ordering.

CATALOG NO.	PERSONAL RECORD CARDS	PRICE
FC334	100 EACH	\$16.95
FC334M	1,000 EACH	\$115.00
FC334M5	5,000 EACH	\$360.00

CHILD FINGERPRINT CARDS

SIRCHIE®'s Child Fingerprint Cards are printed on standard format 8" x 8" fingerprint record cards and they're designed specifically for fingerprinting children. Space is provided on the card for recording pertinent information about both the child and parents. The cards are printed on the best 110-pound index card stock. They will not wrinkle or crease when placed in a typewriter. An excellent choice for "CHILD" identification programs.

CATALOG NO.	CHILD FINGERPRINT CARDS	PRICE
FC335	100 EACH	\$16.95
FC335M	1,000 EACH	\$115.00
FC335M5	5,000 EACH	\$360.00



PRINTOVER™ TABS ON A ROLL

These opaque, adhesive-backed tabs are designed to cover poor impressions on standard fingerprint cards so individuals may be reprinted. They're die cut to fit perfectly on 8" x 8" record cards.

CATALOG NO.	PRINTOVER™ TABS ON A ROLL	PRICE
FPT107R	ROLL OF 100	\$9.50
FPR108R	ROLL OF 500	\$21.00

PRINTOVER™ TABS (INDIVIDUALLY CUT)

These "crack-and-peel" adhesive-backed tabs are designed to cover poor impressions on standard fingerprint record cards so individual fingerprints may be reprinted. They are opaque white tabs and are easily peeled and attached to the record card. Packaged: 1,000/plastic case.

Specifications	FPT109
Net Weight	11.5 oz. (326 g)
Dimensions	1 5/16" x 1 1/2" (3.3 cm x 3.8 cm)



CATALOG NO. FPT109	PRINTOVER TABS, 1,000 EACH	\$21.95
--------------------------	----------------------------------	---------

FINGERPRINT TAKING AND RECORDING PRODUCTS

BUREAU FINGERPRINT AND PALM PRINT RECORD CARD FILE CABINET (FOR STANDARD 8" x 8" CARDS)

These are the finest filing cabinets available for 8" x 8" fingerprint record cards. Each drawer of the cabinet features a double compartment to accommodate two rows of 8" x 8" cards. Each row will accommodate 2,000 cards; each drawer will accommodate 4,000 cards.

The cabinet has five drawers—offering a capacity potential of 20,000-8" x 8" fingerprint record cards. Each cabinet is precision-built to the smallest spring and catch. The case is made totally of heavy-gauge, cold-rolled steel. Every drawer moves effortlessly on thick, ribbed-steel guides and 10 roller bearings.

Systematic spot-welding throughout assures structural integrity. This is a filing cabinet designed to endure years of continual service.

Leading Particulars

- Five Drawer
- Double Compartment Drawers
- Heavy-Gauge, Steel Fabrication
- Rib and Roller Bearing Drawers
- Accommodate 20,000 Cards
- Dimensions—52" H x 28" D x 18 3/4" W
- Weight—275 lbs.

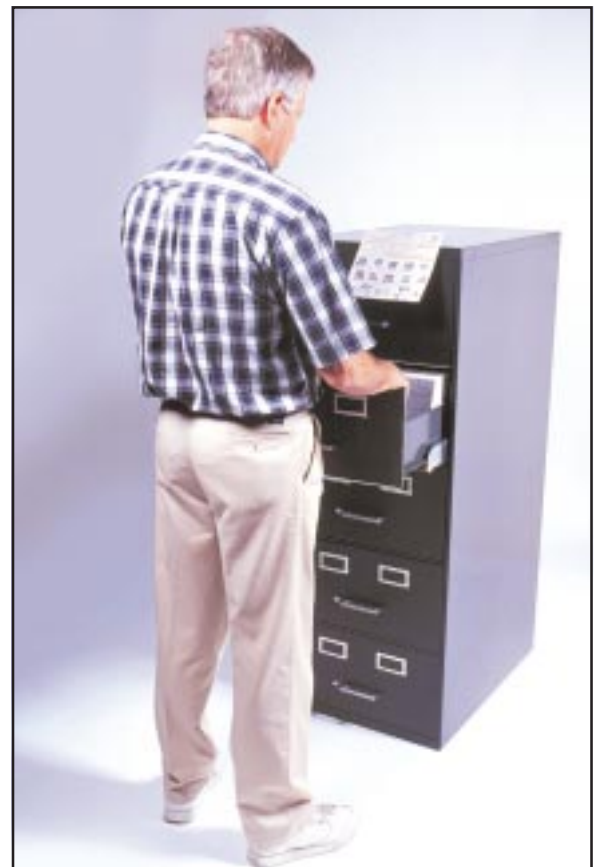

BUREAU FINGERPRINT AND PALM PRINT RECORD CARD FILE CABINET			
CATALOG NO.	COLOR	LOCK	PRICE
MSC100G	GRAY*	NO	\$1,128.50
MSC100GL	GRAY*	YES	\$1,228.00
*BLACK OR TAN AVAILABLE UPON REQUEST. REQUIRE 60-DAY DELIVERY TIME.			

LATERAL DRAWER FILING CABINET

The Lateral Drawer Filing Cabinet offers a very practical alternative to the traditional filing cabinets used by most identification bureaus. The lateral drawer filing cabinet offers a shallow depth drawer that eliminates the long stretch to reach cards in the rear of the file. File cards front to back with row separators. In bureaus where cabinet space is at a premium, these cabinets are ideal because they require only one half the depth of standard files.

A unique drawer interlock prevents cabinet tip-over because only one drawer may be opened at a time. Double-walled-steel construction and a polyurethane finish provide years of trouble-free service.

Leading Particulars

- Depth—19"
- Full Suspension—Drawer Extensions: 16 5/8"
- Lock Standard
- Mechanical Interlock Prevents Tipping
- Roll-Out Cradle Drawer Support with Slide Movement
- Material: 0.035" (0.89 mm) (#20 Ga.) Cold-Rolled Steel
- Capacity: 4-Drawer Model—Approximately 18,000 8" x 8" Fingerprint Record Cards
- Weight: 196 Pounds (88.9 kg)
- Dimensions: 53" x 36" x 19"
- Color: Gray Only

CATALOG NO. MSC400 ... PRICE: \$1,098.00



**BLANK METAL TAB GUIDE CARDS
(FOR 8" x 8" FINGERPRINT RECORD CARDS)**

SIRCHIE[®] Blank Metal Tab Guide Cards are perfect for the Bureau Fingerprint Card Cabinet. These guide cards are designed to allow departments to develop their own guide card system and expand as needed. Guides are constructed of durable pressboard stock. Steel tabs are firmly staked to the guide and furnished in position from first to fifth. Card strip inserts and a celluloid cover are furnished with each guide.



CATALOG NO.	QUANTITY	PRICE
FG228	100	\$186.00
FG2285	500	\$765.00
FG228M	1,000	\$1,315.00

FINGERPRINT TAKING AND RECORDING PRODUCTS

SPACE-AGE CERAMIC TECHNOLOGY: EZID STAINFREE™

It is well known that the leading cause of poor impressions is over-inking of the fingers. The EZID is an ink-pad system which is able to compensate for poor technique and uncooperative subjects by not only controlling the amount of ink on the pad surface but by eliminating the effects of overpressure. Through the use of a finely pored ceramic substrate, EZID pads draw ink to the surface by capillary action. EZID ink is a STAINFREE™, high-contrast, instant-drying, permanent ink. It does not contain any water or alcohol that will dry out the pad. Nor will the pad surface degenerate or crumble. Three sizes are available: EZID Micro Pad is 1 5/8" dia.; EZID200 Mini Pad is 2" dia. and the EZID300 Rectangular Pad is 2 1/2" x 4".



This is the Ceramic Surface Fingerprint Ink Pad, No. EZID, in use.

- STAINFREE™
- PERMANENT INK
- HIGH-CONTRAST
- CERAMIC SURFACE
- RED OR BLUE STAINFREE™ INK AVAILABLE UPON REQUEST

CATALOG NO.	FINGERPRINT INK PAD	PRICE
EZID100	MICRO PAD, 1 5/8"	\$7.95/EACH
EZID200	MINI PAD, 2"	\$14.95/EACH
EZID300	RECTANGULAR PAD, 2 1/2" X 4"	\$39.50/EACH
EZID600	PACK OF 6 MICRO PADS, 1 5/8"	\$40.00

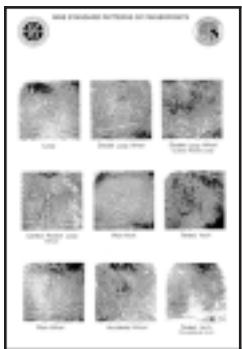

No. FC348

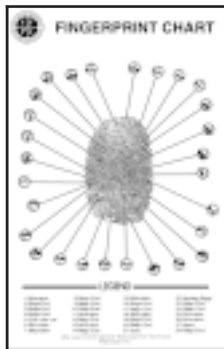

No. FC349

FINGERPRINT WALL CHARTS

A. No. FC348 (Left). This large, 17" x 22" wall chart illustrates nine of the most common fingerprint patterns. It is a useful reference and teaching aid.

CATALOG NO. FC348 PRICE: \$14.95

B. No. FC349 (Right). This handy 17" x 22" wall chart illustrates and names common fingerprint comparison characteristics. It too is a very useful reference and teaching tool.

CATALOG NO. FC349 PRICE: \$14.95

FINGERPRINT VIDEO

This instructive video teaches the proper techniques for rolling and recording fingerprints and palm prints. Experienced instructors demonstrate often-overlooked steps and tips for taking perfect prints. International formats (FPV100IN) are available. Please specify format of international tapes when ordering.

CATALOG NO. FPV100 PRICE: \$29.95

CATALOG NO. FPV100IN PRICE: \$39.95



The Science at Your Fingertips™ Educational Series:

Fingerprint identification advanced as an educational pursuit.

The Fingerprint Instructor Portfolio advances fingerprint identification training utilizing hands-on activities, classroom demonstrations, interactive classroom projects, complete lesson plans and reproducible graphics.

Students of all ages and skill levels will benefit from these training components. The Fingerprint Instructor Portfolio is designed for identification technician training, police academy instruction, college-level police science courses and school resource officers' classroom instruction.

Leading Particulars

- Gain student interest with fun, hands-on activities that reinforce important identification concepts.
- Implement new training demonstrations that explain fingerprinting theory and procedures to beginning students in a fun and understandable way.
- Improve existing advanced fingerprint classes with lesson plans, supplemental exercises and instruction recommendations.
- Design new instruction blocks for police academies and criminal justice courses.
- Utilize appealing instructional material and project ideas for middle school and high school art, history, math and science classes.
- Prepare your own quizzes, tests, posters and handout material with specially prepared reproducible graphics.
- Purchase the Fingerprint Instructor Portfolio and save \$16.60 compared to the individual component price below.



CAT. NO.	DESCRIPTION	PRICE
FPTC1000	FINGERPRINT INSTRUCTOR PORTFOLIO	\$69.95
FPTC1001	FINGERPRINT LECTURE MANUAL	\$22.95
FPTC1002	FINGERPRINT DISCOVERY KIT	\$28.95
FPTC1003	FINGERPRINT BLOW UP KIT	\$12.95
FPTC1004	FINGERPRINT SUPPLY KIT	\$11.95
FPTC1005	FINGERPRINT FLASH CARDS	\$1.95

SECTION II TABLE OF CONTENTS

Latent Print Development and Lifting Products

Backing/Sketch/Record Cards.....	100-101
Brushes, Latent Print	59-62
Chemical Development	81-82
Cleaner, Fingerprint Powder	104
Cyanoacrylate	76-79
CYANOWAND™	76-77
DFOSPRAY™	75
FACII®	63-64
Fluorescent Powder	57
Fluorescent Magnetic Powder	67
Footprint Lifters	99
Fuming Chambers.....	83-85, 87-89
Hinge Lifters	90-91
Humidifier	86
Iodine Fuming Products	70-71
Latent Print Kits	102-118B
Latent Print Powder	55-56, 58
Lifting Tabs	92-93
Lifting Tape	94-95
Magnetic Applicators	68-69
Magnetic Latent Print Powder	65-67
Ninhydrin	72-73
Palm Lifters.....	96-97
Silver Nitrate	74
Small Particle Reagent	80
Tape Dispensers	95

LATENT PRINT DEVELOPMENT

SIRCHIE® is universally recognized as the leader in the latent print development field.

Latent print development methods and resources have evolved greatly. There are now a multitude of procedures and products which employ both old and new technologies.

SIRCHIE® offers a complete line of products for developing and processing latent prints.

These products include a wide variety of regular and magnetic latent fingerprint powders and applicators, as well as an exceptional line of fluorescent latent powders.

In addition, **SIRCHIE®** offers a comprehensive line of latent print developing reagents, including ninhydrin, silver nitrate, DFO (1,8-Diazafluoren-9-one) and cyanoacrylate (Super Glue).

Properly lifting, transporting, and storing latent prints is as important as developing them.

SIRCHIE® offers a superior line of lifting tapes and accessories to meet these requirements.

Every law enforcement professional should choose **SIRCHIE®** when processing crime scenes for latent fingerprints.

THE LATENT FINGERPRINT

Background:

In a general sense, latent prints may be thought of as those prints left at the crime scene. Such prints may or may not be visible: Visible latents are those showing recognizable ridge detail made by fingers contaminated with substances such as blood, ink, grease or dirt, and which naturally display a contrast with their background; or are made when fingerprints are pressed into plastic (deformable) surfaces such as putty, tar, adhesive-coated surfaces, wax and cheese. Truly latent (“hidden”) prints are not visible to the naked eye, and substantially consist of only the natural secretions of human skin. Such prints require treatment to cause them to become visible. This treatment is called “latent print development.”

Developing the latent requires the technician to utilize some chemical or physical process where the reaction with the skin secretions will cause the latent to stand out against its background.

Choosing the right development tool is a major component of the job of the latent technician. To begin to understand how to choose the right tool, it is necessary to have some understanding of the chemical makeup of the fingerprint.

Most natural fingerprints consist of secretions of the skin’s glands.

In the main, three types of glands are responsible: the eccrine glands, the sebaceous glands and the apocrine glands.

The eccrine glands secrete largely water with both inorganic and organic contaminants. Inorganic components of this type of sweat include chlorides, metal ions, ammonia, sulfates, and phosphates. Organic components include metabolic by-products such as amino acids, urea, lactic acid, choline, uric acid, creatinine and sugars.

Sebaceous glands are secretors of fatty or greasy substances. These include organic compounds such as fatty acids and glycerides, as well as alcohols and hydrocarbons.

Apocrine glands secrete cytoplasm and nuclear materials, including inorganic compounds such as ionic iron, and organic compounds such as proteins, carbohydrates and cholesterol.

Successfully developing a latent print requires choosing an agent that reacts with some combination of these components, but not with the surface on which the print exists. However, just which components exist in a fingerprint and in what concentration are subject to change. Factors such as age, exposure to the environment and the surface on which they reside have profound effects. Water and alcohols are of the first components lost from a print. Thus, agents that react primarily with water will become less effective with the passage of time, whereas agents that rely on reactions with fatty constituents may be more successful. Of course, the surface on which the print is placed may act to absorb or diffuse the fatty components, leaving no discernible ridge detail.

It may be necessary for the latent technician to attempt a number of developers in sequence. However, many development reactions are destructive in that they change the chemical nature of the fingerprint constituent with which they react. When this destruction occurs, the chemical is no longer available within the print to be detected. It is essential that the technician understands the accepted sequence of use of development products.

	Inorganics	Organics
Eccrine	chlorides, metal ions, ammonia, sulfates and phosphates	amino acids, urea, lactic acid, choline, uric acid, creatinine and sugars
Sebaceous		fatty acids and glycerides, alcohol and hydrocarbons
Apocrine	ions like sodium, potassium and iron	proteins, carbohydrates and cholesterol

■ POWDERS

Powders adhere to both water and fatty deposits. These are generally useful on newer prints only. Choose a powder to contrast with the background. They are useful on any dry, relatively smooth, non-adhesive surfaces. Use after laser fluorescence. May be used before ninhydrin and after cyanoacrylate. Results may vary with skill of technician. Lift developed prints by photography or conventional methods. **SIRCHIE®S standard powders are located on pages 55-56 and 58. Standard magnetic powders are located on pages 65-66.**



■ FLUORESCENT POWDERS

Powders made of fluorescent materials offer the advantages to the limitations of conventional powders. Apply as with conventional powders. Lifts can be made photographically or by conventional means. Fluorescent powders are especially useful on confused backgrounds. An ultraviolet or forensic light source is required. **Fluorescent magnetic powders are located on page 67.**



■ IODINE

Iodine fumes react with oils and fatty deposits to produce a temporary yellow-brown reaction product. Iodine is useful on fresh prints on porous and non-porous, non-metallic surfaces. Developed prints must be fixed or photographed immediately because reaction will rapidly fade. Use iodine before ninhydrin and silver nitrate. **Iodine fuming products are located on page 71.**



■ DFO

DFO, 1,8-Diazafluoren-9-one, is a fluorescing ninhydrin analog found to develop up to two and a half more prints than ninhydrin itself. It is useful on porous surfaces, especially paper. Development may be accelerated through the application of controlled heat. Use it before ninhydrin. DFO also is useful to develop weak blood stains. It requires a specialized light source, such as the **BLUEMAXX™. DFOSPRAY™ is located on page 75.**



■ NINHYDRIN

Ninhydrin reacts with amino acids to produce a purple reaction product called "Rhuemann's Purple". It is useful on porous surfaces—especially paper. Development time is up to 10 days, but may be accelerated through the application of heat and humidity. Use ninhydrin after iodine and before silver nitrate. Ninhydrin is not useful on items which have been exposed to water. **Ninhydrin is located on pages 72-73.**



■ SILVER NITRATE

Silver nitrate reacts with the chlorides in skin secretions to form silver chloride, a material which turns gray when exposed to light. Developed prints must be photographed immediately because the reaction will eventually (and permanently) fill the background. It is useful on paper, cardboard, plastics and unvarnished, light-colored woods. Use it after ninhydrin and iodine. It is not useful on items which have been exposed to water. **Silver nitrate is located on page 74.**



■ **PHYSICAL DEVELOPER**

Physical developer is another silver-based developer which reacts to form a dark gray reaction product. It is useful on paper, cardboard and unvarnished, light-colored woods. Use physical developer after ninhydrin and iodine. It is very successful on items exposed to water. **Physical developer is located on page 82.**



■ **SMALL PARTICLE REAGENT**

Small particle reagent is a suspension of fine molybdenum disulfide particles. It adheres to the fatty components of skin secretions to form a gray deposit. Developed prints must be photographed immediately because the reaction product is very fragile. Developed prints may be carefully lifted using conventional methods. Small particle reagent is useful on relatively smooth, non-porous surfaces, including wet ones. It may be used in place of, or after physical developer. **Small particle reagent is located on page 80.**



■ **CYANOACRYLATE (GLUE FUMING)**

Cyanoacrylate fumes react (polymerize) with waters and other possible fingerprint constituents to form a hard, whitish deposit. It is useful on most non-porous and some porous surfaces. Cyanoacrylate produces excellent results on styrofoam and plastic bags. Developed prints may be dusted with powders or treated with fluorescing dyes, such as ardrox and basic yellow to enhance. **Cyanoacrylate products are located on pages 76-79.**



■ **AMIDO BLACK**

Amido black reacts with the proteins found in blood to form a black reaction product. Amido black is useful only on blood-contaminated prints. It is highly sensitive. It is useful on non-porous and some slightly porous surfaces. It sometimes offers successful development of blood prints on dead human skin. **Amido black is located on page 81.**



■ **ADHESIVE SIDE POWDER**

Adhesive side powder attaches itself to plastic print impressions on the adhesive side of tapes. It produces excellent results on light-colored or transparent tapes, including duct tape, masking tape, plastic surgical tape, foam tape, clear and reinforced packing tapes and labels. This process involves wetting tapes. **Adhesive side powder is located on page 81.**



■ **FLUOROCHROMES**

Prints may be treated with special dyes called fluorochromes which easily are made to fluoresce and bond with the print deposits. They are useful with inexpensive forensic lights such as **SIRCHIE**[®]'s **BLUEMAXX**[™]. DFO is a fluorescing ninhydrin analog found to develop up to two and a half times more prints than ninhydrin itself. It is useful on porous surfaces. Development may be accelerated through the application of controlled heat. A specialized light source such as **SIRCHIE**[®]'s **BLUEMAXX**[™] is required. Basic yellow, ardrox and rhodamine are dyes especially useful in conjunction with cyanoacrylate. They require an ultra-violet light source **Fluorochrome products are located on pages 75 and 82.**



QUICK GUIDE TO SURFACES



■ 1. SMOOTH, NON-POROUS:

This category includes glass, hard plastic mouldings (bare metals are not included) and surfaces treated with paint or varnish. Powders, iodine, small particle reagent and cyanoacrylate/fluorescent dyes may be used on these surfaces.

■ 2. ROUGH, NON-POROUS

Rough or textured surfaces and grained plastic mouldings are included in this category. Powders are usually unsuitable on these surfaces. Use small particle reagent or cyanoacrylate/fluorescent dyes.

■ 3. PAPER AND CARDBOARD

These surfaces include paper and cardboard (including plaster board) that have not been waxed or plastic-coated. Treat with iodine, ninhydrin, DFO, silver nitrate or physical developer. However, powders are generally insensitive to older fingerprints.

■ 4. PLASTIC PACKAGING MATERIAL

This category includes polyethylene, polypropylene, cellulose acetate and laminated paper surfaces. Use iodine, small particle reagent, cyanoacrylate/fluorescent dyes and powders. Cyanoacrylate is especially useful on styrofoam.

■ 5. SOFT VINYL (PVC), RUBBER AND LEATHER

These surfaces include simulated leather and cling film. Use iodine, small particle reagent, cyanoacrylate and powders.

■ 6. METAL (UNTREATED)

These surfaces include untreated, bare metal surfaces—not metal surfaces that have been painted or lacquered. Use small particle reagent, powders, cyanoacrylate/fluorescent dyes and powders.

■ 7. UNFINISHED WOOD

This category includes unfinished wood surfaces—that have not been painted or treated. Treat with ninhydrin. Use powders on smooth wood and silver nitrate or physical developer on light woods.

■ 8. WAX AND WAXED SURFACES

This category includes items made of wax (such as candles) and wax-coated paper, cardboard and wood surfaces. Treat with nonmetallic powders and cyanoacrylate/fluorescent dyes.

■ 9. ADHESIVE-COATED SURFACES (NOT PICTURED)

This category includes tapes and similar surfaces that are not likely to dissolve in water. Use adhesive side powders.

Surface	Method
Smooth, non-porous	powders, iodine, small particle reagent, cyanoacrylate/fluorescent dyes
Rough, non-porous	small particle reagent, cyanoacrylate/fluorescent dyes
Paper and cardboard	iodine, ninhydrin, DFO, silver nitrate, physical developer, powders
Plastic packaging material	iodine, small particle reagent, cyanoacrylate/fluorescent dyes, powders
Soft vinyl (pvc), rubber and leather	iodine, small particle reagent, cyanoacrylate, powders
Metal (untreated)	small particle reagent, powders, cyanoacrylate/fluorescent dyes,
Unfinished wood	ninhydrin, powders, silver nitrate, physical developer
Wax and waxed surfaces	nonmetallic powders, cyanoacrylate/fluorescent dyes
Adhesive-coated surfaces	adhesive side powders

“HI-FI” VOLCANO LATENT PRINT POWDER

Using the correct latent fingerprint powder is the most important consideration when developing latent prints. That's why the following powder characteristics always should be considered:

1. The powder's SENSITIVITY TO SECRETIONS
2. The powder's ADHERENCE QUALITIES
3. The powder's REPRODUCTION CAPABILITIES

SIRCHIE®'s “HI-FI” volcano latent print powders offer the best sensitivity, adherence qualities and reproduction capabilities of any powders available. Use them to produce excellent results. All **SIRCHIE®** latent fingerprint powders are packaged with desiccant capsules for storing extended periods (over 12 months) without moisture contamination.



CATALOG NO.	COLOR/TYPE	VOLUME	PRICE
101L	SILK BLACK	2 OZ. (59 ml)	\$6.50
102L	SILK GRAY	2 OZ. (59 ml)	\$6.50
103L	INDESTRUCTIBLE WHITE	2 OZ. (59 ml)	\$6.50
104L	BRILLIANT RED	2 OZ. (59 ml)	\$6.50
105L	SILVER METALLIC	2 OZ. (59 ml)	\$6.95
106L	GOLD METALLIC	2 OZ. (59 ml)	\$6.95
107L	COPPER METALLIC	2 OZ. (59 ml)	\$6.95

“HEAVY” VOLCANO LATENT PRINT POWDER

SIRCHIE®'s “HEAVY” volcano latent print powder is unique because it features density characteristics not found in normal powders, yet maintains the same sensitivity criteria. This powder is formulated especially for assignments requiring a less mobile latent print powder.



CATALOG NO.	COLOR/TYPE	VOLUME	PRICE
HLP01	HEAVY BLACK	2 OZ. (59 ml)	\$8.75
HLP02	HEAVY GRAY	2 OZ. (59 ml)	\$8.75

SIRCHIE® latent print powders are all uniformly packaged in two-ounce volume, extra-wide mouth jars (1 3/4" diameter opening), to accommodate Zephyr, Fiberglas® and feather-type brushes. Net weight of contents will vary according to color and formula. Material safety data sheets (MSDS) are available for all **SIRCHIE®** latent fingerprint powders. Please request on departmental stationery.

LATENT PRINT DEVELOPMENT PRODUCTS



These fingerprints are an example of No. SB201L's multi-background capability.



These fingerprints are an example of No. SG202L's multi-background capability.



These fingerprints are an example of No. SR301L's multi-background capability.



Fingerprints are developed on a galvanized coin box.



“HI-FI” SILVER/BLACK LATENT PRINT POWDER

SIRCHIE®’s “HI-FI” silver/black latent print powder is a two-color powder that will contrast with any color surface. This unique formulation will develop black on light-colored surfaces and silver on dark-colored surfaces. All lifted prints dusted with this powder may be mounted on white backing cards for contrast. Contents: 2 oz. (59 ml).

CATALOG NO. SB201L PRICE: \$9.25

“HI-FI” SILVER/GRAY LATENT PRINT POWDER

This powder combines the “STICK” characteristics of silver metallic powder and the “SLIP” characteristics of silk gray powders. Use it on all glass, plastic laminates, metallic surfaces, high-gloss enamel or varnish surfaces, hard rubber, thermoset plastics and blue-steel weapons. Contents: 2 oz. (59 ml).

CATALOG NO. SG202L PRICE: \$9.25

“HI-FI” SILVER/RED SAFECRACKER LATENT PRINT POWDER

This two-color powder offers unique contrast capabilities with any color surface. It develops bright red on light-colored surfaces and silver on dark-colored surfaces. Use it on metal surfaces such as safes and filing cabinets. This powder also features the unique attributes of both metallic and oxide powders. Contents: 2 oz. (59 ml).

CATALOG NO. SR301L PRICE: \$9.25

“HI-FI” COIN BOX/GALVANIC LATENT PRINT POWDER

SIRCHIE®’s “HI-FI” coin box/galvanic latent print powder is specially formulated to develop latent prints on oily vending machine coin boxes or galvanized surfaces such as window and door flushings, drain pipes, gutters and trash cans. Use this powder in place of older print development methods, such as smoking prints with camphor or magnesium, which are time-consuming, difficult and hazardous. Contents: 2 oz. (59 ml).

CATALOG NO. CBG203L PRICE: \$10.95

“HI-FI” DUAL PURPOSE LATENT PRINT POWDER

SIRCHIE®’s “HI-FI” dual purpose latent print powders are excellent when used with or without an ultraviolet light. Developed prints emit a green glow when exposed to ultraviolet light in subdued light—regardless of the background color. Contents: 2 oz. (59 ml).

CATALOG NO. DP001 DUAL PURPOSE BLACK ... PRICE: \$10.75

CATALOG NO. DP002 DUAL PURPOSE WHITE PRICE: \$10.75

All **SIRCHIE**® latent fingerprint powders are packaged with desiccant capsules for storing extended periods (over 12 months) without moisture contamination.



FLUORESCENT LATENT PRINT POWDERS

Use Fluorescent Latent Print Powders with:

- **Forensic Light Sources:** Quartz Halogen and Vapor Arc Discharge
- **Lasers:** Argon Ion, Copper Vapor and Nd (Neodymium) Yag Laser
- **Ultraviolet Lights:** Longwave and Shortwave
- **BLUEMAXX™:** **SIRCHIE®**'s Alternate Light Source

Fluorescent latent print powders may be used on the same surface types as non-fluorescent powders. Fluorescent latent print powders work especially well on dark or multi-colored surfaces—greatly enhancing ridge details when illuminated with an ultra-violet light. Typically, light in the ultraviolet or blue parts of the spectrum (254 nm to 525 nm) is used to excite the fluorescence.



REDescent™

No. LL701 REDescent fluorescent latent powder fluoresces brilliant red. The powder's natural color is red.

PINKescent™

No. LL702 PINKescent™ fluorescent print powder fluoresces brilliant red. The powder's natural color is pink.

SILVER/REDescent™

No. LL704 SILVER/REDescent™ fluorescent print powder fluoresces brilliant red. The powder's natural color is metallic red.

GREENescent™

No. LL703 GREENescent™ fluorescent print powder fluoresces brilliant green. The powder's natural color is green.

YELLOWescent™

No. LL705 YELLOWescent™ fluorescent print powder fluoresces brilliant yellow. The powder's natural color is yellow.

CATALOG NO.	DESCRIPTION	VOLUME	PRICE
LL701	REDescent	2 OZ. (59 ml)	\$10.95
LL7012	REDescent	16 OZ. (473 ml)	\$41.75
LL702	PINKescent	2 OZ. (59 ml)	\$10.95
LL7022	PINKescent	16 OZ. (473 ml)	\$41.75
LL703	GREENescent	2 OZ. (59 ml)	\$10.95
LL7032	GREENescent	16 OZ. (473 ml)	\$41.75
LL704	SILVER/REDescent	2 OZ. (59 ml)	\$14.25
LL7042	SILVER/REDescent	16 OZ. (473 ml)	\$65.95
LL705	YELLOWescent	2 OZ. (59 ml)	\$10.95
LL7052	YELLOWescent	16 OZ. (473 ml)	\$41.75

FORENSIC PHOTOGRAPHY OF FLUORESCENT-POWDER-DEVELOPED LATENT PRINTS

The prints pictured below were developed with **SIRCHIE®**'s fluorescent powder and photographed using Kodak® GoldPlus 100 Film, ISO 100/21°. The typical aperture setting and exposure time for illumination are listed below. Prints were illuminated with the **BLUEMAXX™** BM600 120 VAC, tripod-mounted. Camera-to-target distance: 10" (25 mm). Intensity enhancement: maximum.



LL701
15 sec F5.6

LL702
15 sec F5.6

LL703
15 sec F5.6

LL704
15 sec F5.6

LL705
30 sec F8

LATENT PRINT DEVELOPMENT PRODUCTS

“HI-FI” VOLCANO LATENT PRINT POWDER

SIRCHIE®’s “HI-FI” volcano latent print powders are available in bulk for greater economy and convenience. Bulk containers feature an extra-wide mouth for easy refilling of smaller containers.

CATALOG NO.	COLOR/TYPE	VOLUME	PRICE
BPP00116	DUAL PURPOSE BLACK	16 OZ. (473 ml)	\$53.00
BPP0018	DUAL PURPOSE BLACK	8 OZ. (237 ml)	\$31.95
BPP00216	DUAL PURPOSE WHITE	16 OZ. (473 ml)	\$53.00
BPP0028	DUAL PURPOSE WHITE	8 OZ. (237 ml)	\$31.95
BPP09128	SILK BLACK	128 OZ. (3,785 ml)	\$216.50
BPP0916	SILK BLACK	16 OZ. (473 ml)	\$31.95
BPP0964	SILK BLACK	64 OZ. (1,893 ml)	\$123.50
BPP098	SILK BLACK	8 OZ. (237 ml)	\$18.95
BPP19128	INDESTRUCTIBLE WHITE	128 OZ. (3,785 ml)	\$216.50
BPP1916	INDESTRUCTIBLE WHITE	16 OZ. (473 ml)	\$31.95
BPP1964	INDESTRUCTIBLE WHITE	64 OZ. (1,893 ml)	\$123.50
BPP198	INDESTRUCTIBLE WHITE	8 OZ. (237 ml)	\$18.95
BPP201128	SILVER/BLACK	128 OZ. (3,785 ml)	\$328.00
BPP20116	SILVER/BLACK	16 OZ. (473 ml)	\$46.50
BPP2018	SILVER/BLACK	8 OZ. (237 ml)	\$28.95
BPP203128	COIN BOX/GALVANIC	128 OZ. (3,785 ml)	\$328.00
BPP20316	COIN BOX/GALVANIC	16 OZ. (473 ml)	\$46.50
BPP2038	COIN BOX/GALVANIC	8 OZ. (237 ml)	\$28.95
BPP29128	BRILLIANT RED	128 OZ. (3,785 ml)	\$216.50
BPP2916	BRILLIANT RED	16 OZ. (473 ml)	\$31.95
BPP2964	BRILLIANT RED	64 OZ. (1,893 ml)	\$123.50
BPP298	BRILLIANT RED	8 OZ. (237 ml)	\$18.95
BPP301128	SILVER/RED	128 OZ. (3,785 ml)	\$328.00
BPP30116	SILVER/RED	16 OZ. (473 ml)	\$46.50
BPP3018	SILVER/RED	8 OZ. (237 ml)	\$28.95
BPP302128	SILVER/GRAY	128 OZ. (3,785 ml)	\$328.00
BPP30216	SILVER/GRAY	16 OZ. (473 ml)	\$46.50
BPP3028	SILVER/GRAY	8 OZ. (237 ml)	\$28.95
BPP39128	SILK GRAY	128 OZ. (3,785 ml)	\$216.50
BPP3916	SILK GRAY	16 OZ. (473 ml)	\$31.95
BPP3964	SILK GRAY	64 OZ. (1,893 ml)	\$123.50
BPP398	SILK GRAY	8 OZ. (237 ml)	\$18.95
BPP4916	SILVER METALLIC	16 OZ. (473 ml)	\$39.95
BPP498	SILVER METALLIC	8 OZ. (237 ml)	\$23.25
BPP5916	COPPER METALLIC	16 OZ. (473 ml)	\$39.95
BPP598	COPPER METALLIC	8 OZ. (237 ml)	\$23.25
BPP6916	HEAVY BLACK	16 OZ. (473 ml)	\$42.95
BPP698	HEAVY BLACK	8 OZ. (237 ml)	\$26.50
BPP7916	HEAVY GRAY	16 OZ. (473 ml)	\$42.95
BPP798	HEAVY GRAY	8 OZ. (237 ml)	\$26.50
BPP8916	GOLD METALLIC	16 OZ. (473 ml)	\$39.95
BPP898	GOLD METALLIC	8 OZ. (237 ml)	\$23.25



No. BPP0018



No. BPP00116



No. BPP0964



No. BPP09128

All **SIRCHIE**® latent fingerprint powders are packaged with desiccant capsules for storing extended periods (over 12 months) without moisture contamination.

FIBERGLAS® LATENT PRINT BRUSHES

This is unquestionably one of the finest brushes available for developing latent fingerprints. Thousands of specially selected Fiberglas® filaments form a soft cluster that retains powder and eliminates the constant powder replenishment required for conventional brushes. It is produced on a perfectly balanced, machine-knurled, black anodized aluminum handle for the ultimate in control. The brush is supplied in a protective container and cap.



The Fiberglas® latent print brush, No. 122L, is pictured in use.

ments form a soft cluster that retains powder and eliminates the constant powder replenishment required for conventional brushes. It is produced on a perfectly balanced, machine-knurled, black anodized aluminum handle for the ultimate in control. The brush is supplied in a protective container and cap.

← The kit size Fiberglas® brush, No. 122L1, is pictured left, actual size.

The standard size Fiberglas® brush, No. 122L, is pictured right, actual size. →



FIBERGLAS® LATENT PRINT BRUSHES

- SUPERB FIBERGLAS® FILAMENTS
- ABSENCE OF GRAINY FIBERS
- FREE OF SPURIOUS OILS
- UNIFORM CONICAL TAPER

Combined to form a cloud-like cluster of thousands of fibers. Use these brushes on any surface with volcano powders for the ultimate latent print developing combination.



The No. 122L and No. 122L1 feature a precision-balanced aluminum handle.

STANDARD SIZE FIBERGLAS® BRUSH

Leading Particulars

- Bristles: Fiberglas® filament cluster, 2 1/8" long
- Brush Handle: Black anodized knurled aluminum, 1/4" dia. x 4 1/4" long
- Storage Container: Clear acetate tube, 7/8" dia. x 7 1/2" long

CATALOG NO. 122L..... STANDARD PRICE \$10.95

KIT SIZE FIBERGLAS® BRUSH

A reduced handle length makes this brush an exact replacement for conventional brushes found in most fingerprint field kits now in use.

Leading Particulars

- Bristles: Fiberglas® filament cluster, 2 1/8" long
- Brush Handle: Black anodized knurled aluminum, 1/4" dia. x 2 3/4" long
- Storage Container: Clear acetate tube, 7/8" dia. x 6" long

CATALOG NO. 122L1 KIT SIZE PRICE: \$9.95

**SEARCH® FIBERGLAS®
RETRACTABLE BRUSH**



Opened

Closed

Actual Size

This is an excellent brush that features a Fiberglas® cluster cloud. The cloud may be controlled and incrementally adjusted. Simply move the retracting shroud and adjust the flair. The shroud protects the Fiberglas® cluster and ensures unequalled protection from foreign particle contamination, moisture and rough usage.

Leading Particulars

- Controlled, incremental adjustment of Fiberglas® flair
- Protection from foreign particles



The No. RFF200 is pictured in use.

Specifications

- Machine-knurled Delrin® shroud assembly
- Machined Delrin® plastic handle
- "O" ring friction seal
- Infinite brush flair adjustment
- Kit and pocket size—6 3/4" x 1" dia.
- Weight: 2.4 ounces
- Black Delrin® with custom cap

CATALOG NO. RFF200 PRICE \$21.95

FIBERGLAS® SWEEPER BRUSH



SIRCHIE®'s Fiberglas® sweeper brush is an excellent choice for processing automobiles, doors, windows, desks-tops and other large surface areas. It features the same high-quality Fiberglas® filament brush surface as **SIRCHIE®**'s other Fiberglas® brushes. The brush's precision-machined handle makes it very balanced and comfortable to hold. The brush is supplied with a plastic storage container.

Leading Particulars

- Precision-machined and balanced handle
- Thousands of "soft-cluster" Fiberglas® brush elements
- Excellent powder retention
- Large area processing, 4" wide sweep



The Fiberglas® sweeper brush features balanced control.

CATALOG NO. FGB100 PRICE: \$30.75

**SEARCH® MARABOU
FEATHER DUSTER**

The marabou feather duster is designed for use as a primary powder applicator or as a secondary enhancement brush. The brush is exceptionally soft and is available with black or white feathers.

Leading Particulars

- Made of the finest down feathers available—soft, with no quills
- Designed for large coverage areas, such as auto bodies, walls, doors and windows
- Brush is supplied with a protective storage container and cap
- Feathers from African marabou stork

CATALOG NO.	DESCRIPTION	PRICE
123LB	BRUSH, BLACK	\$7.25
123LW	BRUSH, WHITE	\$7.25



No. 123LB is pictured actual size.

SEARCH® CARBOSMOOVE I BRUSH

about ... **CARBON FILAMENT LATENT PRINT BRUSHES**

SIRCHIE®'s carbon filament latent print brushes feature the very latest in latent print development technology. Carbon fiber brushes are unequalled because carbon fibers are naturally smooth and feature a low friction quality. In addition, carbon fibers are corrosion- and moisture-resistant—ensuring the finest brush even in extremely high humidity. The fine-diameter filaments are randomly layered—allowing the user to quickly change powder colors simply by shaking the brush free of initial powder.

Property	U.S. Units-Values
Tensile strength	220,000 lb/in ²
Density	35 × 10 ⁶ lb/in ³
Filament diameter	9 microns
Carbon assay	98%

The **SEARCH®** carbosmoove I brush is the softest cluster brush available—comprised of tens of thousands of specially selected carbon filaments. The brush features an anodized aluminum, machine-knurled handle with superb balance for complete powder control. Each brush is individually packaged in a plastic tube with cap.

Leading Particulars

- Overall Length: 7.0"
- Carbon Filament Length: 2.0"
- Net Weight: 6.7 oz.
- Handle: Black anodize knurled aluminum



The carbosmoove I brush, No. CFB100, is pictured in use.

CATALOG NO. CFB100	PRICE: \$21.95
--------------------------	----------------

LATENT PRINT DEVELOPMENT PRODUCTS

SEARCH® REGULAR POWDER BRUSH

This is a general-purpose brush made of high-quality camel hair. The fine bristle quality permits development without distortion. The brush is supplied with a protective container and cap. The brush dimensions are: 5 1/4" x 3/8" dia. (13.3 cm x 1 cm dia.).



Actual Size

CATALOG NO. 118L REGULAR POWDER BRUSH PRICE: \$4.25

SEARCH® SPREAD POWDER BRUSH

The spread powder brush features superb quality hair selection, increased hair concentration and width. The brush also features an easy-grip, molded-plastic handle. The brush is supplied with a protective container and cap. The brush dimensions are: 4 1/2" x 3/8" x 1/8" (11.4 cm x 1 cm x 0.3 cm).



Actual Size

CATALOG NO. 119L SPREAD POWDER BRUSH PRICE: \$9.25

SEARCH® MAX-SPREAD POWDER BRUSH

The max spread brush is recommended for processing large surfaces. The brush features an easy-grip, molded-plastic handle designed for complete powder control. The brush is supplied with a protective container and cap. The brush dimensions are: 4 1/8" x 3/8" x 1/8" (10.5 cm x 1.3 cm x 0.3 cm).



Actual Size

CATALOG NO. 120L MAX-SPREAD POWDER BRUSH PRICE: \$10.25

LONG HANDLE BRUSH

This is the finest, high-quality, long handle latent print brush available. It is produced from selected, high-quality camel hair for latent powder applications only. The fine hair selection eliminates scratching ridge details. The handle is balanced for easy use. The brush is supplied with a protective container and cap. The brush dimensions are 9" x 1/2" dia. (22.9 cm x 1.3 cm dia.).

CATALOG NO. LHB02 LONG HANDLE BRUSH PRICE: \$14.25

Actual Size



the **SIRCHIE®** ...
FACII®

**CLEAN ENOUGH TO
STORE IN YOUR SHIRT
POCKET**

Patent No. 8,248,543

FACII® POWDER/BRUSH DELIVERY SYSTEM

SIRCHIE®'s revolutionary FACII® powder/brush delivery system has become the standard for many investigators in the latent print development field. The FACII® features a unique, patented, self-contained powder delivery system. The system supplies powder directly into the brush filaments—providing a very neat and efficient processing procedure.

The FACII®'s cluster cloud Fiberglas® brush element may be adjusted by moving the unit's shroud up and down—for total control over both the size and firmness of the brush cluster.

HERE'S HOW IT WORKS: Adjust the shroud to the desired brush size. Then, gently squeeze the attached powder reservoir to force a controlled amount of powder into the brush filaments. The brush is now ready to use—it's that simple! After use, close the shroud and store. It is clean enough to store in a shirt pocket!

The FACII®'s housing is constructed of machine-knurlled Delrin®, and it is properly balanced for user comfort. All of the FACII® components may be ordered, interchanged and cleaned separately—for greater efficiency.



*This is the FACII®
pictured actual size.*

About the unit ...

The unit's unique self-contained powder and brush delivery system may be carried like a pen or pencil. After use, simply return the brush's protective sleeve to its original position and place the protective cap on the open end.

FACII® Specifications	
DIMENSIONS:	
Length of extended assembly	6 1/2"
Length of sleeve retraction	2"
Weight:	
Mechanical assembly less reservoir	2.4 oz.
1 oz. volume powder with dehydrate	.4 oz.
Fully loaded and assembled	2.8 oz.
MATERIALS AND FINISHES:	
Parts	Machine-knurlled Delrin®
Cap	Machine-knurlled Delrin®
Reservoir	Molded polyethylene, flame treated
Brush of Fiberglas® filament	
Length of cluster	1.87"
Cluster base diameter	.55"
Average cluster flare diameter	3"

CATALOG NO.	POWDER COLOR, 1 OZ. VOLUME	PRICE
FAC101	SILK BLACK	\$32.95
FAC102	SILK GRAY	\$32.95
FAC103	INDESTRUCTIBLE WHITE	\$32.95
FAC106	SILVER/BLACK	\$35.95
FAC201	SILVER/GRAY	\$35.95
FAC202	SILVER/RED	\$35.95
FAC203	COIN BOX/GALVANIC	\$36.25
FAC401	REDESCENT™ FLUORESCENT	\$36.25
FAC402	GREENESCENT™ FLUORESCENT	\$36.25
FAC403	YELLOWESCENT™ FLUORESCENT	\$36.25
FAC404	SILVER/REDESCENT™ FLUORESCENT	\$38.50



The FACII® powder/brush delivery system is pictured in use.



FACII® REPLACEMENT POWDERS

FACII® system powder refills are packaged in one-ounce, molded polyethylene, flame-treated containers. Each container contains a desiccant capsule to prevent moisture contamination. Actual weight varies according to color.

CATALOG NO.	COLOR DESCRIPTION	PRICE
FAC1011	SILK BLACK	\$5.50
FAC1021	SILK GRAY	\$5.50
FAC1031	INDESTRUCTIBLE WHITE	\$5.50
FAC1061	SILVER BLACK	\$6.75
FAC2011	SILVER/GRAY	\$6.75
FAC2021	SILVER/RED	\$6.75
FAC2031	COIN BOX/GALVANIC	\$7.75

FACII® FLUORESCENT REPLACEMENT POWDERS



SIRCHIE®'s superb line of fluorescent latent print powders is now available in FACII® refill form. These powders fluoresce brilliantly when exposed to forensic light sources.

CATALOG NO.	COLOR DESCRIPTION	PRICE
FAC4011	REDESCENT™	\$9.95
FAC4021	GREENESCENT™	\$9.95
FAC4031	YELLOWESCENT™	\$9.95
FAC4041	SILVER/REDESCENT™	\$9.95

FACII® +2 LATENT PRINT KIT



The FACII® +2 latent print kit contains the necessary tools to process a crime scene for latent prints with the FACII® powder/brush delivery system. Each kit is supplied with two FACII® brush combinations, as well as a variety of hinge lifters.

No. FAC1000 consists of:

- 12- No. 130LT1 Transparent Hinge Lifters, 1.5" x 2"
- 4- No. 131LT1 Transparent Hinge Lifters, 2" x 4"
- 4- No. 131LB1 Black Hinge Lifters, 2" x 4"
- 4- No. 131LW1 White Hinge Lifters, 2" x 4"
- 1- No. FAC101 Silk Black FACII® Powder/Brush Combination
- 1- No. FAC103 Indestructible White FACII® Powder/Brush Combination
- 1- No. FAC10001 Custom-Molded Carrying Case

CATALOG NO. FAC1000 FACII® +2 LATENT PRINT KIT PRICE: \$76.95



SIRCHIE®'s standard magnetic applicator, No. 125L is pictured in use with **SIRCHIE®**'s magnetic latent print powder.

about **SIRCHIE®** MAGNETIC LATENT PRINT POWDERS

SIRCHIE®'s magnetic latent print powders feature superior ferrous compounds thanks to a unique ball-milling processing which ensures uniform, textured powders—every time. These powders are the finest available. Use on any non-ferrous surface.

SIRCHIE® MAGNETIC LATENT PRINT POWDERS

These powders may be used with any magnetic applicator available—permanent or electronic. They are available in one-ounce volumetric jars with a content weight of approximately 3 ounces, depending on color selection.



CATALOG NO.	COLOR	VOLUME	PRICE
M114L	REGULAR BLACK	1 OZ. (30 ml)	\$7.25
M115L	MIDNIGHT BLACK	1 OZ. (30 ml)	\$7.25
M116L	WHITE	1 OZ. (30 ml)	\$7.25
M117L	GRAY	1 OZ. (30 ml)	\$7.25
M118L	RED	1 OZ. (30 ml)	\$7.25
M119L	SILVER	1 OZ. (30 ml)	\$8.25



MAGNETIC LATENT PRINT POWDER

These magnetic latent print powders are packaged specifically for use with large magnetic applicators, such as the **SIRCHIE®** GigaMag™. Powder volume: 5 oz. (148 ml). Approx. weight: 12-18 ounces, depending on color selection.

CATALOG NO.	TYPE	VOLUME	PRICE
MSW114L	REGULAR BLACK	5 OZ. (148 ml)	\$17.75
MSW115L	MIDNIGHT BLACK	5 OZ. (148 ml)	\$17.75
MSW116L	WHITE	5 OZ. (148 ml)	\$17.75
MSW117L	GRAY	5 OZ. (148 ml)	\$17.75
MSWSBM10	SILVER/GRAY	5 OZ. (148 ml)	\$19.75
MSWSBM12	SILVER/RED	5 OZ. (148 ml)	\$20.95
MSWSBM9	SILVER/BLACK	5 OZ. (148 ml)	\$19.75

SIRCHIE®'s magnetic latent print powder is available in extra-wide-mouth containers for use with any magnetic applicators.

LATENT PRINT DEVELOPMENT PRODUCTS

SILVER/BLACK MAGNETIC LATENT PRINT POWDER



SILVER/GRAY MAGNETIC LATENT PRINT POWDER



SILVER/RED MAGNETIC LATENT PRINT POWDER



SIRCHIE®'s silver/black magnetic latent print powder will contrast with any color surface. This unique formulation will develop black on light surfaces (picture top) and silver on dark surfaces (picture bottom). Volume: 1 oz. Approx. Weight: 3 oz.

This powder features the fine adherence properties of **SIRCHIE**®'s silver magnetic powder and the excellent "slip" properties of the gray magnetic powder. It develops gray on light surfaces (picture top), silver on dark surfaces (picture bottom). Volume: 1 oz. Approx. Weight: 3 oz.

SIRCHIE®'s silver/red magnetic latent print powder is a dual-color powder that develops red on light surfaces (picture top) and silver on dark surfaces (picture bottom). Volume: 1 oz. Approx. Weight: 3 oz.

CATALOG NO. SBM9 SILVER/BLACK MAGNETIC LATENT PRINT POWDER PRICE: \$9.50
 CATALOG NO. SBM10 SILVER/GRAY MAGNETIC LATENT PRINT POWDER PRICE: \$9.50
 CATALOG NO. SBM12 SILVER/RED MAGNETIC LATENT PRINT POWDER PRICE: \$10.50

MAGNETIC LATENT PRINT POWDER (BULK PACKAGED)

These powders are packaged in 16-ounce and 128-ounce bulk sizes and feature ultra-wide mouths for use with the largest magnetic sweeper wands. Net weight will vary according to color selection.

CATALOG NO.	COLOR	VOLUME	PRICE
BPM114L	REGULAR BLACK	16 OZ. (473 ml)	\$42.50
BPM114L128	REGULAR BLACK	128 OZ. (3,785 ml)	\$265.00
BPM115L	MIDNIGHT BLACK	16 OZ. (473 ml)	\$42.50
BPM115L128	MIDNIGHT BLACK	128 OZ. (3,785 ml)	\$265.00
BPM116L	INDESTRUCTIBLE WHITE	16 OZ. (473 ml)	\$42.50
BPM116L128	INDESTRUCTIBLE WHITE	128 OZ. (3,785 ml)	\$265.00
BPM117L	GRAY	16 OZ. (473 ml)	\$42.50
BPM117L128	GRAY	128 OZ. (3,785 ml)	\$265.00
BPM118L	RED	16 OZ. (473 ml)	\$42.50
BPM118L128	RED	128 OZ. (3,785 ml)	\$265.00
BPM119L	SILVER	16 OZ. (473 ml)	\$45.25
BPM119L128	SILVER	128 OZ. (3,785 ml)	\$265.00
BPMSBM10	SILVER/GRAY	16 OZ. (473 ml)	\$52.00
BPMSBM12	SILVER/RED	16 OZ. (473 ml)	\$53.00
BPMSBM9	SILVER/BLACK	16 OZ. (473 ml)	\$52.00
BPMSBM9128	SILVER/BLACK	128 OZ. (3,785 ml)	\$265.00



SIRCHIE® FLUORESCENT "CHARGE" MAGNETIC POWDERS

Use **SIRCHIE®**'s fluorescent magnetic powders with:

- **Forensic Light Sources:** Quartz Halogen and Vapor Arc Discharge
- **Lasers:** Argon Ion, Copper Vapor and Nd (Neodymium) Yag Laser
- **Ultraviolet Lights:** Long Wave and Shortwave
- **BLUEMAXX™:** **SIRCHIE®**'s Alternate Light Source



FLUORESCENT MAGNETIC LATENT PRINT POWDERS

SIRCHIE®'s fluorescent magnetic latent print powders feature bright pigments, superior ferrous compounds and an anti-smudge additive to ensure superior results when dusting for latent prints. **SIRCHIE®**'s unique ball-mill processing produces the finest uniform-textured magnetic latent print powders available today. These powders are especially useful when used on multicolored backgrounds. They can be applied with virtually all magnetic powder applicators. View dusting area with an ultraviolet blue or green forensic light source (254 nm to 365 nm) to see results.

CATALOG NO.	NATURAL COLOR	FLUORESCENCE	VOLUME	PRICE
LL601	REDCHARGE™	BRILLIANT RED	1 OZ.	\$6.75
LL6012	REDCHARGE™	BRILLIANT RED	16 OZ.	\$49.50
LL602	ORANGECHARGE™	BRILLIANT ORANGE	1 OZ.	\$6.75
LL6022	ORANGECHARGE™	BRILLIANT ORANGE	16 OZ.	\$49.50
LL603	GREENCHARGE™	BRILLIANT GREEN	1 OZ.	\$6.75
LL6032	GREENCHARGE™	BRILLIANT GREEN	16 OZ.	\$49.50
LL605	YELLOWCHARGE™	BRILLIANT YELLOW	1 OZ.	\$6.75
LL6052	YELLOWCHARGE™	BRILLIANT YELLOW	16 OZ.	\$49.50



**FLUOROMAG™
LATENT PRINT POWDER**

This powder combines the "no-contact" advantage of magnetic powder with a highly fluorescent compound for use on multicolored backgrounds. The natural color of this is silver/gray. However, it appears bright yellow/green when illuminated with an ultraviolet light. Volume: 2 oz.



CATALOG NO.	NATURAL COLOR	FLUORESCENCE	PRICE
FMP01	SILVER/GRAY	YELLOW/GREEN	\$10.75

LATENT PRINT DEVELOPMENT PRODUCTS

MAGNETIC POWDER APPLICATORS

Use magnetic powders with **SIRCHIE**®'s magnetic wands to eliminate the risk of latent print ridge destruction. One main advantage is that it is easy to clear surfaces of excess powder—offering maximum photographic effectiveness. **SIRCHIE**®'s magnetic applicators may be used with any brand of magnetic powder. Use on nonferrous surfaces only.



NO. 125MD
(actual size)



NO. 125GM



NO. 125L
(actual size)

STANDARD POWDER APPLICATOR

SIRCHIE®'s standard magnetic applicator is ideal for precision dusting of small to medium surface areas. The unit features a narrow magnet that will fit any size powder container. A convenient pocket clip allows for maximum portability. Weight: 0.9 oz.

CATALOG NO. 125L.....PRICE: \$18.50

MEGAWAND™ POWDER APPLICATOR

The **SEARCH**® MegaWand™ features an expanded coverage area designed especially for dusting a large surface area. The wand holds approximately three times as much powder as the standard wand. The wand features a machined Delrin® housing with spring-loaded ejection. Weight: 1.6 oz.

CATALOG NO. 125MD PRICE: \$21.75

GIGAMAG™ POWDER APPLICATOR

The GigaMag™ magnetic wand sweeper is the only choice for maximum coverage. This wand holds approximately nine times as much powder as the standard wand. It features a rugged, precision-machined Delrin® housing. Weight: 6.8 oz.

CATALOG NO. 125GM PRICE: \$42.50



The No. 125GM is pictured in use.



The No. 125MD is pictured in use.



The No. 125L is pictured in use.

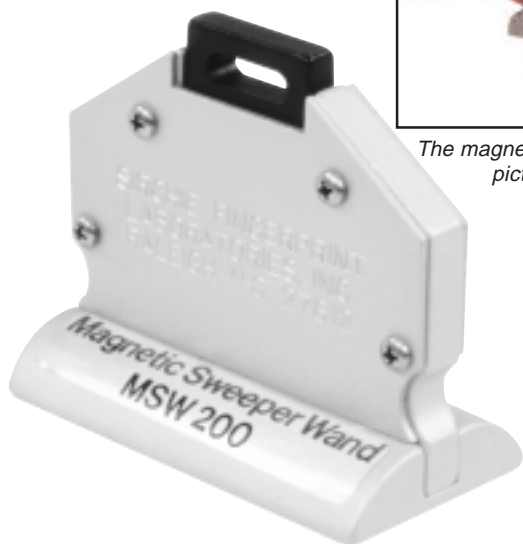

The magnetic sweeper wand is pictured in use.



The Wonda-Wand™ is pictured in use.

No. MSW200 actual size

MAGNETIC SWEEPER WAND

This magnetic sweeper wand features a very wide sweep area—a minimum of two inches. With a powder capacity of approximately seven times the standard magnetic wand, this wand is ideal for covering large surface areas. The wand's powder release features a positive-lock pull handle. The unit's housing is made of precision-machined aluminum. Weight: 5.7 oz. (160 g).

CATALOG NO. MSW200 PRICE: \$38.95

The latest development in magnetic powder applicators ... the **SEARCH®** Wonda-Wand™!

WONDA-WAND™

The new **SEARCH®** Wonda-Wand™ allows the user to select the proper amount of powder for dusting fingerprints by adjusting the strength of its powerful magnet. The amount of powder may be regulated by adjusting the magnet. This feature is useful for attracting excess powder after dusting—reducing the possibility of damaging the fragile print ridges. Weight: 2 oz. (58 g).

CATALOG NO. 125WW PRICE: \$49.95



SEARCH® REGULAR MAGNETIC LATENT PRINT KIT



This is the most popular, compact, magnetic latent print kit available. Use this kit to process a crime scene with magnetic powder and magnetic applicators. It is excellent for developing latent prints on paper, cardboard, finished and unfinished wood, glass, vinyls and on any nonferrous material. Complete instructions are included. Dimensions: 8 3/8" x 7 1/4" x 3" Net Weight: 2.1 lbs. (.93 kg)

No. 159 consists of:

- 1-No. M114L Black Magnetic Latent Powder, 1 oz.
- 1-No. M116L White Magnetic Powder, 1 oz.
- 1-No. M117L Gray Magnetic Powder, 1 oz.
- 1-No. SBM9 Silver/Black Magnetic Latent Powder, 1 oz.
- 1-No. 125L Standard Magnetic Applicator
- 1-No. KC100 Molded Plastic Carrying Case with Component Inserts

CATALOG NO. 159L..... PRICE: \$43.25

FUMETTE™

THE DISPOSABLE IODINE FUMING GUN BY SIRCHIE®

Leading Particulars

- All plastic outer casing
- Pre-measured 2.0-gram iodine crystal ampoule
- No leakage—may be stored or carried anywhere
- Simple to use, efficient and totally effective
- Disposable and economical



FUMETTE™s are available in packages of six.

NOTICE: Prior to using the products on the following pages, read and follow all instructions and warnings provided with these products. Material safety data sheets are available on all **SIRCHIE®** products. Please request by catalog number on department's stationery.

FUMETTE™ DISPOSABLE IODINE FUMING GUN

The FUMETTE™ disposable iodine fuming gun is truly a state-of-the-art advancement in processing a crime scene for latent fingerprints through the use of iodine fuming.

The FUMETTE™ is compact and very effective for fuming walls and woodwork with iodine vapor for latent prints. The FUMETTE™'s design permits fuming both vertical and horizontal surfaces.

The FUMETTE™ is also excellent for fuming small objects with iodine vapor because it gives the user total control of the fuming operation. A hinged cap allows containment of iodine when not in use.

The FUMETTE™ makes it possible to process any surface with iodine vapor anytime, anywhere. When the fuming process is complete, simply recap and dispose of the whole assembly.

CATALOG NO. DF2016 PRICE: \$28.75

SIRCHIE® Finger Print Laboratories developed Iodette™ ampoules for processing fresh latent prints (up to 48 hours) on paper, currency, tissue and most other porous and non-porous surfaces other than metals. They are designed primarily for quick processing in the field or lab utilizing plastic or polyethylene bags. Placed in a resealable bag, the Iodettes™ create an instant fuming chamber. Iodettes™ have an unlimited shelf life, and they're clean and convenient to use. Iodettes™ are packaged in 3-gram glass ampoules. There are six ampoules per jar.

IODETTES™ BY SIRCHIE®

- FIELD OR LAB
- DOCUMENTS
- CURRENCY
- QUICK
- CLEAN
- DISPOSABLE

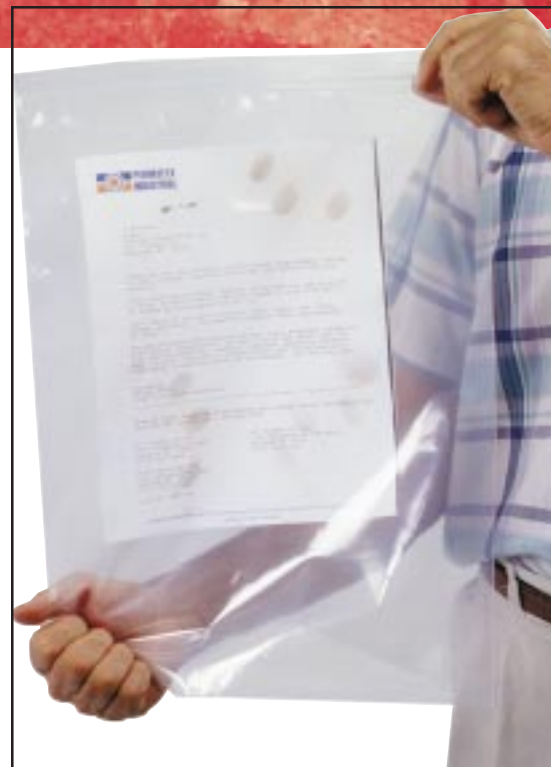

Place Iodettes™ in a plastic bag and create an instant fuming chamber.

CATALOG NO. AMP2066 IODETTE™ AMPOULES, 6 EACH PRICE: \$32.50

SEARCH® IODINE CRYSTAL AMPOULES

SIRCHIE®'s iodine crystals are packaged and sealed in glass ampoules. They are absolutely safe for storage in kits—no vapor loss is possible. Plus, they're very convenient and clean. To open, simply break at the pre-scored neck and empty. They may be used with any type of fuming apparatus. Each ampoule contains three grams of iodine crystals. There are six ampoules per jar.



CATALOG NO. A211C IODINE CRYSTAL AMPOULES, 6 EACH PRICE: \$14.25

SEARCH® IODINE PRINT ENHANCERS

The **SEARCH®** iodine print enhancer package consists of six crushable glass ampoules filled with reagent (1.0 ml). The ampoules are housed in plastic applicator tubes. Crush the ampoule, remove the applicator tube cap and apply the reagent to the iodine-developed print. These print enhancers offer an unlimited storage life and are completely disposable. Enhancers contain benzoflavone. They are clean, convenient and easy-to-use.



CATALOG NO. DCA16 IODINE PRINT ENHANCERS, 6 EACH PRICE: \$23.25

LATENT PRINT DEVELOPMENT PRODUCTS



about NINHYDRIN ...

Ninhydrin is a general purpose reagent designed for developing latent prints on paper and other porous surfaces. It reacts with amino acids and other components in fingerprints which yield amino acids when broken down. Ninhydrin produces a colored image, which may vary from orange to purple depending on latent print constituents and development conditions. Full development may take several weeks to occur, although the reaction may be accelerated through heat and humidification.

USE IT ON:

Latent fingerprints and blood-contaminated fingerprints on porous surfaces such as paper, cardboard, paper cartons, currency, raw wood, plasterboard, etc.

NOT SUITABLE ON:

Non-porous surfaces and wet articles.

PERFORMANCE:

Simple to use and very effective. It will detect fingerprints months or years old.

ACCELERATED DEVELOPMENT:

Reaction may be accelerated by applying heat and humidity. See No. 213C and No. 214C fuming chambers and No. PUM1002 portable humidifier.



SIRCHIE® NINHYDRIN SPRAY

This is the most widely used formulation of ninhydrin in the world. It has developed prints over two-years old in actual cases and 50-year-old prints in experimental cases. Ninhydrin is bottled in an aerosol can for increased shelf life and convenient field or laboratory use. Two sizes are available.

CATALOG NO. 201C 16 OZ. VOLUME AEROSOL PRICE: \$17.75
CATALOG NO. 202C 6 OZ. VOLUME AEROSOL PRICE: \$8.75

SIRCHIE® NINHYDRIN SPRAY WITH ACETONE

This is a custom formulation of ninhydrin in an acetone solution. It is used and recommended by leading experts in the latent print processing field for increased sensitivity. Ninhydrin with acetone is designed for use on porous surfaces, such as paper, cardboard, and raw wood (but not on materials printed with soluble inks or paints). Available in a 16-ounce aerosol only.

CATALOG NO. 201ACE ... 16 OZ. VOLUME AEROSOL ... PRICE: \$16.50



NEED

A ninhydrin formulation which may be sprayed on a document in a controlled manner and which virtually eliminates the problem of ink running.

FULFILLMENT

SIRCHIE®'s SPECIAL FORMULA NINHYDRIN SPRAY.

This spray is an outstanding solvent which may be applied to the document in a controlled manner without ink-running problems.

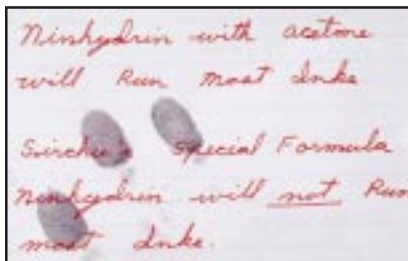

Latent prints are developed on a document with special formula ninhydrin spray—no ink running.

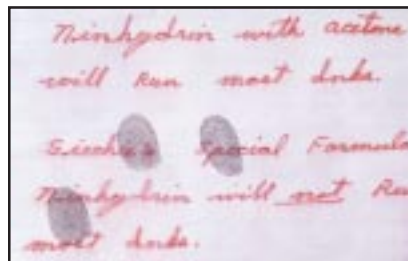

Latent prints are developed on a document with an acetone-base solvent—ink running.

SPECIAL FORMULA NINHYDRIN SPRAY

Use **SIRCHIE**®'s special formula ninhydrin spray to develop latent prints on printed documents, currency, envelopes, magazines, books and other documents. This spray is ideal for developing latent prints on paper because it virtually eliminates ink from running. The spray is nonflammable.

CATALOG NO. NSI609 8 OZ. SPRAY PUMP PRICE: \$21.95



NINHYDRIN CRYSTALS

Ninhydrin crystals are available in 25-gram, 100-gram and 500-gram jars for agencies that prefer to mix their own unique formulations.

1,2,3-TRIKETOHYDRINDENE HYDRATE CRYSTAL (NINHYDRIN)

Sensitivity to Amino Acids Color Pons Test

Solubility in Water Clear and Complete

Loss on Drying at 105°C Not More Than 11.0%

CATALOG NO. NRP01 25-GRAM JAR PRICE: \$29.95

CATALOG NO. NRP02 100-GRAM JAR PRICE: \$79.95

CATALOG NO. NRP03 500-GRAM JAR PRICE: \$249.50

NINHYDRIN FIXATIVE

Use **SIRCHIE**®'s ninhydrin fixative to preserve latent prints developed with ninhydrin—after they've been photographed. That's because latent prints developed with ninhydrin may fade over time. Ninhydrin fixative not only preserves the developed prints, but in some cases it enhances and tints them. Ninhydrin fixative is supplied in an 8-ounce bottle with a controlled-application pump spray.

CATALOG NO. NFS200 8 OZ. WITH SPRAY PUMP PRICE: \$12.25

See **SIRCHIE**®'s portable humidifier and heat chambers for processing prints treated with ninhydrin.



LATENT PRINT DEVELOPMENT PRODUCTS

about SILVER NITRATE ...

Silver nitrate reacts with chlorides present in latent fingerprints to produce silver chloride, a compound which turns dark grayish-brown when exposed to light. Selectivity in use is a consideration since some background materials contain chlorides. Silver nitrate is especially effective for developing latent prints on raw wood and when used sequentially on paper documents as the final process (iodine fuming, ninhydrin and then silver nitrate). Each method responds chemically to different constituents of a latent print.

- A. IODINE—Absorption and Unsaturated Fats
- B. NINHYDRIN—Amino Acids
- C. SILVER NITRATE—Chlorides



SEARCH® SILVER NITRATE SPRAY

This is a general purpose methanolic silver nitrate solution. A convenient spray head permits application in the field or laboratory. The surface being treated should be sprayed lightly and evenly. After treatment, the article should be permitted to dry completely, preferably in the dark (approximately two minutes). After drying, illuminate the treated surface with high-intensity light (sunlight) or **SIRCHIE**®'s No. SNA4 silver nitrate accelerator lamp. Fingerprints will appear as dark grayish-brown images and should be photographed before the article background develops.

CATALOG NO. 205C 8 OZ. W/SPRAY HEAD PRICE: \$27.50

SILVER LATENT PRINT SPRAY

Silver latent print spray is an exceptional formula for developing latent prints on porous surfaces. This is a chloride-sensitive, non-aqueous solution that is particularly useful when processing documents or objects printed with water soluble inks or dyes. That's because most inks will not dilute when treated with this solvent. The processing and development procedures are the same as stated for silver nitrate spray, No. 205C. Use **SIRCHIE**®'s silver nitrate accelerator lamp (pictured below) for developing prints rapidly.

CATALOG NO. SLPS300 8 OZ. W/SPRAY HEAD PRICE: \$30.75



SEARCH® SILVER NITRATE ACCELERATOR LAMP

SIRCHIE®'s silver nitrate accelerator lamp rapidly develops latent prints treated with silver nitrate. The unit is battery operated—ideal for use in the field or laboratory. A rugged, thermoplastic housing protects the four-watt shortwave-emitting tube.

Dimensions: 6" x 2" x 7/8"
 Bulb Protector: Clear Styrene
 Batteries: Four 1.5-Volt AA (Supplied)



SEARCH® SILVER NITRATE CRYSTAL AMPOULES

SIRCHIE®'s silver nitrate crystals are hermetically sealed in glass ampoules for unlimited shelf life. They are packaged in amber containers for protection against light.

Six 2.2-gram ampoules are supplied in each container.



CATALOG NO. SNA4 PRICE: \$37.95 CATALOG NO. SN208 PRICE: \$31.50



(1,8-DIAZAFLOUREN-9-ONE) BY **SIRCHIE®**

about **DFO ...**

DFO is an amino acid fluorochrome used for developing latent prints on paper and other porous surfaces. As with all fluorescent reagents, DFO is especially useful on multi-colored surfaces—where contrast varies from point to point. Although it is a ninhydrin analog, DFO develops up to 2 1/2 times the number of prints that ninhydrin alone develops.

DEVELOPING DFO-TREATED PRINTS

Latent prints processed with DFO develop slowly unaided. Development may be accelerated by applying heat to the latent print surface. The optimum temperature for developing DFO-treated prints has been determined to be 100°C (212°F). That's why **SIRCHIE®** designed several fuming chambers, including the No. DFC100 and No. DFC200 to provide this optimum acceleration environment.

about **DFO FLUORESCENCE ...**

Although, latent prints developed with DFO may sometimes exhibit visual indicators similar to Rhuemann's Purple, prints should be judged by fluorescent techniques. DFO is a fluorescence agent which attaches to latent print residues and causes them to emit light when illuminated with an ultraviolet light or alternate light source, such as **SIRCHIE®**'s **BLUEMAXX™**.

DFO development may be repeated numerous times to enhance development.

DFO is available in a 4-ounce aerosol can.



CATALOG NO. DFS200 PRICE: \$49.95



DFO (1,8-DIAZAFLOUREN-9-ONE) POWDER

DFO powder is a ninhydrin analogue excellent for developing latent prints on most white and pastel papers. DFO also works well on transparent papers (glassine), such as the kind frequently used to transport illegal drugs. DFO may develop up to two and a half times more latent prints than ninhydrin alone. If DFO and ninhydrin are to both be used on a particular set of prints, DFO should be used first because it will not interfere with the subsequent use of the ninhydrin. Latent prints developed with DFO will fluoresce in the 450 nm-485 nm wavelength range.

CATALOG NO.	DESCRIPTION	PRICE
LV500	1 g	\$49.95
LV5001	5 g	\$225.00



The
SEARCH[®]
CYANOWAND[™]
Latent Fingerprint Developer



The
SEARCH[®]
CYANOWAND[™]

DESCRIPTION

The CYANOWAND[™] is a self-igniting, butane-powered heat tool. It is nonelectric and is used as a flameless heat tool with variable temperature control.

Specifications

Overall length with heat tip
246.3 mm (9.7")

with heat tip and cartridge
267.6 mm (10.537")

Weight: (when gas filled)
126 g (4.4 oz.)

Gas Container Capacity
28 ml (1.6 cu. in.)

Operating Time
Maximum 4 hours

Ignition System
Piezoelectric (requires no batteries)

THE SEARCH[®] CYANOWAND[™]

The CYANOWAND[™] is an easy-to-use, completely portable, hand-held heat generator which utilizes disposable cartridges using a cyanoacrylate monomer to emit cyanoacrylate vapor for fuming latent prints. The CYANOWAND[™] is designed for use at outdoor crime scenes, processing stolen vehicles, in well-ventilated indoor areas and with fuming chambers.

about **LATENT FINGERPRINT DEVELOPMENT
WITH CYANOACRYLATE (SUPER GLUE) ...**

Cyanoacrylate (ethyl or methyl) vapor polymerizes on most latent prints found on nonporous surfaces. This chemical reaction produces a visible, white deposit.

USE IT ON:

Most nonporous surfaces such as plastics, metals (finished and unfinished), glass, enamel or varnished wood surfaces, cellophane, metal foils and plastic-coated papers.

NOT SUITABLE ON:

Most porous surfaces or older latent fingerprints.

CYANOWAND™ KIT

The CYANOWAND™ is incredibly simple to use. Simply attach a cyanoacrylate cartridge, ignite and begin fuming. Hold the CYANOWAND™ several inches away from the suspect surface and sweep the wand back and forth. Latent prints develop as they're fumed. The CYANOWAND™ also offers superb fuming capabilities when used with **SIRCHIE®**'s fuming chambers.



The CYANOWAND™ is pictured with a standard cartridge.

SEARCH® CYANOWAND™ FINGERPRINT KIT

This kit contains all the necessary materials to process latent fingerprints with cyanoacrylate fuming. The kit includes instructions.

No. SCW100 consists of:

- 1-No. SCW101 CYANOWAND™ Heat Generator, with Protective Head Cover
- 1-No. SCW103 Butane Fuel Can, 1.3 oz.
- 1-No. SCW104 Cartridge Extraction Tool
- 1-No. SCW200 CYANOWAND™ Cartridge (Pack of 10)
- 1-No. SCW105 Carrying Case, Copolymer with Foam Inserts

CATALOG NO. SCW100 PRICE: \$153.95

STANDARD CARTRIDGES



SCW200

MEGA-CARTRIDGES



SCW300

HULK CARTRIDGES



SCW400

These disposable cartridges are pre-loaded with cyanoacrylate. They emit a controlled cyanoacrylate vapor for approximately **TWO MINUTES**.

Mega-Cartridges are extra-large, disposable, pre-loaded cyanoacrylate cartridges which emit vapor for approximately **FOUR MINUTES**.

Each Hulk Cartridges will typically fume continuously for more than **ONE HOUR** or for ten 5-minute "burn" cycles.

CATALOG NO. SCW200 STANDARD CARTRIDGES, PACKAGE OF 10 PRICE: \$25.25

CATALOG NO. SCW300 MEGA-CARTRIDGES, PACKAGE OF 10 PRICE: \$43.95

CATALOG NO. SCW400 HULK CARTRIDGES, PACKAGE OF 4 PRICE: \$52.95

CATALOG NO. SCW4001 HULK CARTRIDGE, EACH PRICE: \$13.25

CYANOWAND™ BUTANE FUEL

Refuel the CYANOWAND™ with this butane fuel. It is available in a standard 1.3 oz. can and a 5.3 oz. can. Cans feature nozzles for direct refilling of the CYANOWAND™.



CATALOG NO.	BUTANE FUEL CAN	PRICE
SCW103	1.3 OZ.	\$2.50
SCW1035	5.3 OZ.	\$4.50



THE FINDER™

• ONE-STEP CYANOACRYLATE LATENT FINGERPRINT DEVELOPING SYSTEM

THE FINDER™ is a unique gel formulation sandwiched between two layers of aluminum foil. Place the packet horizontally or vertically in a fuming chamber—without dripping any glue.

Leading Particulars

- A clean, simple and very efficient method of area fuming
- FINDER™ packets are easily stored and carried
- Self-adhesive strip

HOW TO USE THE FINDER:

For fuming small objects ... Place the item in an appropriate sealable container. Peel open the packet and place it in the container with object being processed. Fuming begins immediately. After development, reseal packet. Additional items may be fumed using the same packet.

For fuming vehicle interiors ... Seal the vehicle from outside air and place three to four packets in different locations inside the car. Warm the vehicle interior by parking the car in sun or turning on the heat. Next, add humidity with **SIRCHIE®**'s No. PUM1002 portable humidifier. Allow the vehicle interior to fume for 20 minutes to a few hours. After development, reseal packets and ventilate vehicle. Then, photograph developed prints, dust and lift.

Rooms or areas that can be closed off should be processed in a similar manner.

THE FINDER™ by **SIRCHIE®** is a safe, simple and convenient latent print processing system completely self-contained in a foil packet.

Simply peel the foil packet apart and let THE FINDER™ do the rest. THE FINDER™'s fumes react with latent fingerprint residues to produce the most durable cyanoacrylate-developed prints possible.

Packets may be used for more than one fuming session. Simply reseal and use until exhausted (usually about 15 hours, depending on conditions). Not sold individually.

CATALOG NO.	QUANTITY	PRICE
CNA2000	5 PACKETS	\$15.96
CNA2001	20 PACKETS	\$55.80
CNA2002	100 PACKETS	\$232.40
CNA2003	300 PACKETS	\$680.00



Prepare THE FINDER™ for use by pulling apart the foil packet.

about **CYANOACRYLATE (SUPER GLUE) ... IN LIQUID FORM**

Super Glue vapor, ethyl or methyl cyanoacrylate, polymerizes on most latent fingerprints to produce a white deposit. This polymerization is thought to be catalyzed by the water and possible other components of latent fingerprint deposits.

USE IT TO DEVELOP PRINTS ON:

Most non-porous materials such as plastics, metal (finished and unfinished), fabrics, glass and finished woods

NOT RECOMMENDED FOR USE ON:

Most porous materials or old fingerprints

PERFORMANCE:

Simple to use and very effective

ACCELERATED DEVELOPMENT:

Processing time and sensitivity increased with controlled high humidity (80%)
(see **SIRCHIE®**'s No. PUM1002 portable humidifier on page 86)

ENHANCEMENT:

Magnetic powder, fluorescent powder, basic yellow, ardrex and rhodamine 6G



OMEGA-PRINT™ (16 OUNCES/454 GRAMS) BY SIRCHIE®

SIRCHIE®'s 16-ounce bottle of Omega-Print™ is designed for departments that process a large number of latent prints with cyanoacrylate. Omega-Print™ is supplied with four 2-ounce applicator bottles to maintain the integrity of the bulk container and to permit drop application to dispersal pads and disposable fuming trays. Omega-Print™ is one of the leading choices of many law enforcement agencies throughout the world.

CATALOG NO. CNA103 16-OUNCE W/FOUR APPLICATOR BOTTLES..... PRICE: \$49.50

OMEGA-PRINT™ CYANOACRYLATE FUMING COMPOUND (20 GRAMS)



This economically sized container is the ideal for those departments that do not need a large quantity of cyanoacrylate. The container is supplied with a drop-dispensing cap that is resealable to ensure the integrity of the cyanoacrylate solution while in storage.

CATALOG NO. CNA102..... 20-GRAM BOTTLE..... PRICE: \$4.96

OMEGA-PRINT™ CLEANING COMPOUND

SIRCHIE®'s Omega-Print™ cleaning compound is a must when processing surfaces for latent fingerprints with cyanoacrylate compounds. This solvent dissolves Super Glue residues from most surfaces. It is excellent for cleaning the inside of cyanoacrylate fuming chambers. The solvent is supplied in an eight-ounce bottle with spray head or in a four-ounce bottle without a spray head.

CATALOG NO. CNA108 8 OZ. WITH SPRAY HEAD PRICE: \$24.25

CATALOG NO. CNA109 4 OZ. WITHOUT SPRAY HEAD PRICE: \$13.25



OMEGA-PRINT™ DISPOSABLE FUMING TRAY

OMEGA-PRINT™ DISPERSAL PADS

Use these dispersal pads with any cyanoacrylate liquid fuming compounds. They are not treated with sodium hydroxide and do not create highly toxic fumes. Pads packaged in quantities of 100.

CATALOG NO. CNA104 PRICE: \$10.95/100

Use the disposable fuming tray with or without dispersal pads. Trays are made of aluminum. They are designed for fuming with cyanoacrylate liquid fuming compounds. Trays are packaged in quantities of 25.

CATALOG NO. CNA 106 PRICE: \$8.25/25

LATENT PRINT DEVELOPMENT PRODUCTS



SEARCH® SMALL PARTICLE REAGENT (SPR)

Small particle reagent firmly attaches to the fatty constituents found in latent prints to form a residue. It is a quick, inexpensive and more effective on fresh fingerprints than older ones.

USE IT ON: All NON-POROUS surfaces such as exterior vehicle bodies, exterior gloss-painted surfaces, glass, waxed and plastic-coated materials, polyethylene and expanded polystyrene.

NOT SUITABLE ON: Porous surfaces such as paper and cardboard.

SURFACE CONDITIONS: Wet or Dry.

NOT RECOMMENDED ON: Indoor or outdoor surfaces where property damage may occur. SPR is quite messy and requires cleaning with water to remove reagent residue prior to photography and lifting.

ADVANTAGES: Inexpensive, NON-TOXIC, quick and easy-to-use.

TYPES: No. SPR100 dark suspension for light-colored surfaces, No. SPR200 white suspension for dark-colored surfaces and No. SPR400UV fluorescent (longwave or shortwave, alternate light sources and **BLUEMAXX™**) fluorescent for multi-colored surfaces or light and dark-colored surfaces.

WHEN CONVENTIONAL POWDER METHODS WON'T WORK—SEARCH® SPR



Apply SPR to a non-porous surface, such as an automobile exterior.



These are the resultant prints.



Apply SPR to a non-porous surface, such as a broken window.



These are the resultant prints.

OTHER APPLICATIONS

- OILY WINDOWS
- OXIDIZED METALS
- GALVANIZED SURFACES
- SALT-SPRAYED SURFACES (SEA WATER AREAS)



SEARCH® SMALL PARTICLE REAGENT (SPR) is supplied in three 500 ml containers. Each bottle is furnished with a No. SPR1002 dispenser spray head. Select No. SPR100 for light-colored surfaces, No. SPR200 for dark-colored surfaces or No. SPR400UV for multi-colored surfaces. See page 105 for the SPR Field Kit.

CATALOG NO.	DESCRIPTION	PRICE
SPR100	(3) 500-ml BOTTLES, DARK W/SPRAY HEAD	\$29.95
SPR200	(3) 500-ml BOTTLES, WHITE W/SPRAY HEAD	\$29.95
SPR400UV	(3) 500-ml BOTTLES, FLUORESCENT W/SPRAY HEAD ...	\$49.95

MORE ... CHEMICAL DEVELOPMENT AND ENHANCEMENT OF FRICTION RIDGE SKIN

Cyanoacrylate-developed prints often may be enhanced and improved by processing with fluorescent dyes. These dye-treated prints then should be examined for fluorescence with a laser, ultraviolet light, or a forensic alternate light source (254 nm-365 nm)



ADHESIVE SIDE POWDER

Adhesive side powders are excellent for developing latent prints on the adhesive side of tapes and labels, including duct tape, masking tape, plastic surgical tape, double-sided foam tape, clear plastic tape, reinforced package tape, Band-Aids™, packing labels and other light-colored adhesive surfaces. Select black or white powder for surface contrast and/or the fluorescent green powder for visualization under an alternate light source, an ultraviolet light or the BLUEMAXX™. Simple application when used with **SIRCHIE**®'s EZFLO solution, Cat. No. ASP51.

- CATALOG NO. ASP50D ADHESIVE SIDE POWDER, DARK, 50 g PRICE: \$19.95
- CATALOG NO. ASP50L ADHESIVE SIDE POWDER, LIGHT, 50 g PRICE: \$19.95
- CATALOG NO. ASP50F ADHESIVE SIDE POWDER, FLUORESCENT, 50 g PRICE: \$24.95
- CATALOG NO. ASP51 EZFLO SOLUTION, 6 OZ. PRICE: \$6.95

DFO (1,8-DIAZAFLOUREN-9-ONE) POWDER



DFO powder is a ninhydrin analogue excellent for developing latent prints on most white and pastel papers. DFO also works well on transparent papers (glassine), such as the kind frequently used to transport illegal drugs. DFO may develop up to two and a half times more latent prints than ninhydrin alone. If DFO and ninhydrin are to both be used on a particular set of prints, DFO should be used first because it will not interfere with the subsequent use of the ninhydrin. Latent prints developed with DFO will fluoresce in the 450 nm-485 nm wavelength range.

CATALOG NO.	DESCRIPTION	PRICE
LV500	1 g	\$49.95
LV5001	5 g	\$225.00

CRYSTAL VIOLET

Crystal violet is a dye that will transfer visible color to the fatty components of sebaceous sweat residue in latent prints, producing a highly concentrated, intense, purple image. It is very effective in the development of latent prints on items having a glutinous or sticky adhesive quality, including tape and protective films with adhesive coatings. Crystal violet is also effective on grease- and oil-contaminated surfaces. Instructions are included.



CATALOG NO.	DESCRIPTION	PRICE
LV502	25 g	\$7.95
LV5021	100 g	\$30.50

RHODAMINE 6G

Rhodamine 6G is one of the most widely used dyes for enhancing latent prints developed with cyanoacrylate. Technical information, formulas and procedures are included with each order.



- CATALOG NO. LV505 25 g PRICE: \$9.95

AMIDO BLACK



Amido black is useful for enhancing latent prints contaminated with blood. Although it will not detect the typical chemical components of latent prints, amido black is very sensitive to the proteins found in blood. It leaves a black/blue stain and is usable on both porous and nonporous surfaces. Instructions and formulations are included.

CATALOG NO.	DESCRIPTION	PRICE
LV501	25 g	\$9.95
LV5011	100 g	\$38.95

BASIC YELLOW

This dye is excellent for enhancing cyanoacrylate-developed latent prints on multi-colored surfaces. It fluoresces brilliantly with ultraviolet or BLUEMAXX™ illumination.



- CATALOG NO. LV507 25 g PRICE: \$9.95

LATENT PRINT DEVELOPMENT PRODUCTS

PHYSICAL DEVELOPER SET



Physical developer is a silver-based aqueous reagent that reacts with the components of sebaceous sweat in latent fingerprints to form a silver-gray deposit. Physical developer is superior in sensitivity to many silver nitrate products presently in use. It is ready for immediate use after combination, and it may be used to develop latent prints on paper and some other porous materials. Normally, physical developer is used on latent prints after they've been treated with ninhydrin. Each set consists of two solutions. Mix the solutions and immerse documents in the mixture. Rinse and wait for prints to develop. A technical information sheet and procedure recommendations are included with each set, which includes A and B solutions.

CATALOG NO. LPD100..... 1 LITER SET PRICE: \$42.95
CATALOG NO. LPD101..... 1 GALLON (3.8L) SET PRICE: \$135.00



BASIC YELLOW AFTER-FUMING FLUORESCENT DYE SPRAY

SIRCHIE's basic yellow, after-fuming fluorescent dye spray is designed to enhance latent fingerprints that have been developed with cyanoacrylate on non-fluorescent, multicolored surfaces. Latent prints enhanced with basic yellow fluoresce bright yellow/green. Basic yellow is supplied in a 500 ml bottle with a spray head for convenient application. Use **SIRCHIE**'s **BLUEMAXX**[™] or other alternate light sources for viewing results. Net Weight: 15 oz. (425 g). Volume: 16.9 oz. (500 ml).

CATALOG NO. LVS500 BASIC YELLOW SPRAY, 500 ml..... PRICE: \$21.95

ARDROX AFTER-FUMING FLUORESCENT DYE SPRAY

This fluorescent spray is designed for enhancing latent prints that have been developed with cyanoacrylate. Ardrox saturates the latent print surface and remains in the smallest openings—providing excellent ridge details. Prints treated with ardrox fluoresce yellow/green. Ardrox is supplied in a 500 ml bottle with a spray head for convenient application. Use **SIRCHIE**'s **BLUEMAXX**[™] or other alternate light sources for viewing results. Net Weight: 15 oz. (425 g). Volume: 16.9 oz. (500 ml).

CATALOG NO. LVS600ARDROX DYE SPRAY, 500 ml..... PRICE: \$21.95



ARDROX DYE LIQUID



This fluorescent liquid dye readily penetrates and remains in minute crevices of cyanoacrylate-developed prints for exceptional resolution. Being highly fluorescent when exposed to longwave excitation in the 365 nm range, it is very desirable for use as a cyanoacrylate ester polymerized print enhancer. A sheet with working solution recommendations and procedures is included. Use the **BLUEMAXX**[™] or any ultraviolet light source for exposure.

CATALOG NO. LV506ARDROX DYE, 1 GALLON PRICE: \$36.25

LABORATORY TYPE FUMING CABINET AND HEAT CHAMBER

Redesigned from the ground up, the No. 214CA offers the advantages of an environmentally sealed chamber for the processing of fingerprints with ninhydrin, cyanoacrylate and iodine. Because the chamber is constructed of Fiberglas®, it is not subject to the severe corrosive effects of iodine fumes. All parts internal to the chamber are of stainless steel. Upper and lower ports allow for the connection of an exhaust system. The unit's silicone-encapsulated heater is self-limited to surface temperatures of no more than 450° to prevent the possibility of the formation of cyanide gases during glue fuming. A programmable digital temperature controller controls chamber temperature. Optimum ninhydrin processing temperature and iodine fuming settings are available via front panel switches. Processing can be monitored through a large Plexiglas™ front panel. Chambers are supplied with three document hanging rods, six document clips, ninhydrin spray, ninhydrin fixative, iodine crystal ampoules, iodine print enhancers, disposable fuming trays, a watch glass and complete instructions.



No. 214CA Leading Particulars

- Weight: 15 lbs. (6 oz.) (33.8 kg)
- Microprocessor-based digital temperature controller
- 250-watt, stainless-steel strip heater
- Gasket-sealed fuming compartment improves vapor control
- Sturdy steel, aluminum, and Fiberglas® construction
- Stainless steel intake and exhaust ports

No. 214CA consists of:

- 1- No. 202C Ninhydrin Spray, 6 oz. aerosol
- 1- No. A211C Iodine Crystal Ampoule, 6 each
- 10- No. CNA1061 Omega-Print™ Disposable Fuming Trays
- 1- No. DCA16 Iodine Print Enhancer, 6 each
- 1- No. KCP162 Watch Glass
- 1- No. NFS200 Ninhydrin Fixative with Spray Pump, 8 oz.
- 3- Stainless Steel Document Rods
- 6- Stainless Steel Document Clips

CATALOG NO.	DESCRIPTION	PRICE
214CA	SOLID STATE DIGITAL CONTROL, 110 VAC	\$539.95
214CA220	SOLID STATE DIGITAL CONTROL , 220 VAC	\$566.95

LATENT PRINT DEVELOPMENT PRODUCTS

PORTABLE CYANOACRYLATE FUMING CHAMBER



The portable cyanoacrylate fuming chamber, No. CNA900, is assembled and in use.



The No. CNA900 is disassembled and pictured with its carrying case.

The No. CNA900 portable fuming chamber is a cyanoacrylate development chamber designed with field use in mind. Constructed of shatter-resistant 1/4" Plexiglas™, the unit is made to disassemble into flat sheets and fit into a tough, cotton duck carrying case. Total portability means easy, at-the-crime-scene usage. The chamber is easily assembled in less than five minutes, no tools required. The chamber volume is approximately 16 gallons, sufficient for processing multiple items. Transparent walls mean easy monitoring of development. The chamber features an inlet compatible with the No. PUM1002 portable humidifier and No. SCW100 CYANOWAND™, a removable inner shelf and multiple evidence hangers. The No. CNA900 portable fuming chamber kit includes a starter assortment of expendables, including FINDER™ cyanoacrylate packets, magnetic and regular latent powders, a magnetic wand, and a Fibreglas® brush.

No. CNA900 consists of:

- 1-No. 101L Silk Black Latent Powder, 2 oz.
- 1-No. 122L1 Kit Size Fibreglas® Latent Print Brush
- 1-No. 125L Standard Magnetic Applicator
- 1-No. CNA109 Omega-Print™ Cleaning Compound, 4 oz.
- 1-No. CNA2000 FINDER™ Cyanoacrylate Packets, 5 each
- 1-No. CNA9001 Carrying Case, Black Cotton Duck Cloth
- 1-No. CNA9002 Plexiglas™ Fuming Chamber, with Shelf and Hangers
- 6-No. FR1006 Evidence Clip
- 1-No. M114L Black Magnetic Latent Powder

No. CNA990 consists of:

- 1-No. CNA9002 Plexiglas™ Fuming Chamber with Shelf and Hangers
- 1-No. CNA9001 Carrying Case, Black Cotton Duck Cloth
- 6-No. FR1006 Evidence Clip

CATALOG NO. CNA900 FUMING CHAMBER KIT PRICE: \$164.50
CATALOG NO. CNA990 FUMING CHAMBER ONLY PRICE: \$141.95

DISPOSABLE FUMING CHAMBER

The FA100 is a disposable fuming chamber for use in the field or laboratory that provides an enclosed space for fuming with our CYANOWAND™, THE FINDER™ cyanoacrylate glue packets or OMEGA PRINT™ cyanoacrylate fuming compounds. The fuming chamber is made of 0.12" thick, clear PVC. It transports flat and is set up in seconds by simply installing the end caps. The companion fuming assistant stand is all aluminum and assembles or disassembles in seconds. Only the fuming chamber and end caps are disposable while the fuming assistant stand has an unlimited life.

No. FA100 consists of:

- 3-No. FA1012 Fuming Cylinders (Disposable)
- 6-No. FA1013 End Caps (Disposable)
- 1-No. FA101 Fuming Assistant Stand with four (4) Evidence Suspension Clips

Leading Particulars:

Chamber Volume: 268 cubic inches
 Chamber Dimensions Flat: 14 7/8"W x 18"L
 Chamber Dimensions Expanded: 9 1/2" dia. x 18"L



CAT. NO. FA100..... DISPOSABLE FUMING COMBINATION (AS SPECIFIED ABOVE) .. PRICE: \$49.95
CAT. NO. FA103..... DISPOSABLE CHAMBERS W/END CAPS, 9" X 12" (SET OF 3) ... PRICE: \$22.95
CAT. NO. FA101 UNIVERSAL FUMING ASSISTANT STAND PRICE: \$39.95

CYANOACRYLATE LABORATORY FUMING CHAMBER

These cyanoacrylate fuming chambers are designed for use in the laboratory. The No. FR100 features a 1.2-cubic-foot volume for handling multiple articles. A glass enclosure allows for monitoring of the development process. The 1/4" thick clear Plexiglas™ lid, with two built-in evidence support rods and six evidence clips, fits snugly to prevent leaking of fumes into the work area, and has a port compatible with both the No. PUM100 portable humidifier and the No. SCW101 CYANOWAND™. FINDER™ packets, Omega-Print™ cleaning materials, a wire mesh fuming platform, Omega-Print™ dispersal pads and Omega-Print™ disposable fuming trays are included with this chamber.

Specifications

Net Weight
Dimensions

13 lbs. (5.88 kg)
20 1/4" x 14" x 10 1/2"
(51.4 cm x 35.6 cm x 26.7 cm)



No. FR100 consists of:

- 1-No. CNA103 Cyanoacrylate Fuming Compound, 16 oz.
- 1-No. CNA104 Omega-Print™ Dispersal Pads, 100 each
- 1-No. CNA106 Omega-Print™ Disposable Fuming Trays, 25 each
- 1-No. CNA108 Omega-Print™ Cleaning Compound, 8 oz. spray
- 2-No. CNA20001 FINDER™ Cyanoacrylate Packets
- 1-No. FR1001 Chamber with Lid
- 1-No. FR1002 Fuming Platform, Wire Mesh
- 6-No. FR1006 Evidence Clip

CATALOG NO. FR100 PRICE: \$208.50

HEAT-ACCELERATED CYANOACRYLATE LABORATORY FUMING CHAMBER

The No. FR200, designed with the laboratory in mind, features a 4.5-cubic-foot volume. Clear, replaceable Plexiglas™ surfaces on five sides allow for close monitoring of the development process. It features dual heating elements that can be operated independently or simultaneously for cyanoacrylate acceleration and two levels of document rods with nine moveable positions on each level. Inlets, one located on each side panel, are compatible with the No. PUM100 humidifier and the No. SCW101 CYANOWAND™. Cyanoacrylate fuming compound, a wire mesh fuming platform, Omega-Print™ cleaning compound, Omega-Print™ dispersal pads, Omega-Print™ disposable fuming trays and FINDER™ cyanoacrylate packets are included with this chamber. The No. FR200 is excellent for processing numerous items simultaneously.

Specifications

Net Weight
Dimensions

28.7 lbs. (13.02 kg)
31" x 21 3/8" x 12 3/4"
(78.7 cm x 54.3 cm x 32.4 cm)

Leading Particulars

- Clear Panels: Clear Plexiglas™, 6 mm thick
- Document Rods: Stainless steel, 3 1/16" dia. x 30 1/8" long
- Door: Clear Plexiglas™, 6 mm thick
- Door Latches: Nickel-plated steel, adjustable grip
- Frame: Epoxy painted aluminum, black wrinkle

No. FR200 consists of:

- 1- No. CNA103 Cyanoacrylate Fuming Compound, 16 oz.
- 1- No. CNA104 Omega-Print™ Dispersal Pads, 100 each
- 1- No. CNA106 Omega-Print™ Disposable Fuming Trays, 25 each
- 1- No. CNA108 Omega-Print™ Cleaning Compound, 8 oz. spray
- 2- No. CNA20001 FINDER™ Cyanoacrylate Packets
- 1- No. FR1002 Fuming Platform, Wire Mesh
- 16- No. FR1006 Evidence Clips



CATALOG NO. FR200 PRICE: \$654.50

SEARCH® PORTABLE HUMIDIFIER KIT

The No. PUM1002 portable humidifier kit is designed to provide an efficient source of moisture for use in conjunction with latent print development processes which benefit from the presence of high humidity. It is supplied with a two-foot hose which mates with inlet nozzles built into the No. CNA900, No. FR100, No. FR200 and No. 214CA development chambers or to a special moisture dispersion tool. The unit features an iconology steel heating element, humidity level control, removable transparent water tank for easy refill and low water indicator lamp. The water tank has two-gallon capacity, sufficient for 25-hours of continuous operation. Automatic shutdown occurs at low water levels to prevent overheating.



Leading Particulars

- Durable injection molded housing
- Removable transparent tank for easy refill
- High/low humidity level controls
- Power on/off switch
- Special moisture dispersion tool
- Flexible 2-foot long applicator hose (detachable)
- Dimensions 14 1/4" x 8" x 12" (36.2 cm x 20.3 cm x 30.5 cm)
- Net Weight: 7.7 lbs. (3.49 kg)

Use in conjunction with: Nos. CNA900, FR100, FR200 and 214CA development chambers

No. PUM1002 consists of:

- 1-No. PUM100 Portable Humidifier
- 1-No. PUM105 Deionized Water, 500 ml
- 1-No. PUM1001 Carrying Case, Vinyl Covered, Foam-Lined

SIRCHIE®'s Portable Humidifier, No. PUM100, is pictured with its 2-foot hose and special moisture dispersion tool.



The Portable Humidifier, No. PUM100, is pictured in its carrying case with accessories.



The No. PUM100 is pictured in use with the No. FR100 fuming chamber.

CATALOG NO. PUM1002SEARCH® PORTABLE HUMIDIFIER KIT PRICE: \$274.50

DFO DEVELOPMENT CONTROL CHAMBERS



No. DFC100

The No. DFC100 and No. DFC200 are controlled heat chambers designed specifically to accelerate the development of DFO-treated latent prints. (DFO is a fluorescence agent which attaches to fingerprint residues on paper and other porous surfaces and causes them to emit light when suitably viewed. It has been found to develop up to two and a half times the number of prints developed by ninhydrin.) Although DFO-treated prints will slowly develop unaided, research has shown that they can be accelerated safely and significantly by the judicious application of heat. The No. DFC100 and No. DFC200 conform to the findings of current research by independent forensic investigators and laboratories to provide an optimum acceleration environment.



No. DFC200

For efficiency, chambers are designed to allow for the hanging of multiple documents. Removable shelves allow for the development of items not easily hung. Observation through the double-pane, tempered glass door allows monitoring of development without disturbing the controlled atmosphere of the development chamber. The state of development can sometimes be judged by observing visual indicators, but is most accurately judged using fluorescence techniques. Because of its broad excitation band, excitation of DFO-enhanced prints can be accomplished with **SIRCHIE**®'s **BLUEMAXX**™ systems. Emissions are viewed through the barrier filter integrated into **BLUEMAXX**™ systems. No. DFC100 and No. DFC200 feature solid-state, single set point temperature controllers with a digital readout. Although pre-set for optimum DFO development, the temperature is easily adjusted to meet individual needs. Efficient, high-temperature insulation surrounds the oven chambers while automatic cutoff at 220°F reduces the possibility of damage to sensitive papers.

Below, an operator inserts documents into the No. DFC200 for processing.



Specifications	DFC100	DC200
Net Weight	42.5 lbs. (19.28 kg)	73 lbs. (33.11 kg)
Dimensions	26" x 15 7/8" x 13" (66 cm x 40.3 cm x 33 cm)	26" x 26" x 15 7/8" (66 cm x 66 cm x 40.3 cm)

Leading Particulars

- Full length hinge, positive latch
- Silicone door seals
- Baked enamel exterior
- Efficient high-temperature Fiberglas® insulation surrounds the oven chamber
- Solid-state temperature controller with digital temperature readout
- Front mounted on/off switch
- Single set point controller factory set for optimum DFO development
- Easily adjusted to meet individual needs
- Easy-to-clean welded brushed nickeloid oven chamber
- Optically clear, double-pane, tempered-glass door allows both visual and fluorescence monitoring of development without disturbing the controlled atmosphere

CATALOG NO.	DESCRIPTION	PRICE
DFC100	DFO DEVELOPMENT CONTROL CHAMBER, 110V AC	\$744.50
DFC200	DFO DEVELOPMENT CONTROL CHAMBER, 110V AC	\$964.50
DFC100220	DFO DEVELOPMENT CONTROL CHAMBER, 220V AC	\$844.50
DFC200220	DFO DEVELOPMENT CONTROL CHAMBER, 220V AC	\$1,064.50

CYANOVAC I LABORATORY FUMING CHAMBER OUTFIT

Now it's possible to glue-fume large and unwieldy items such as wrinkled plastic bags and the like. In the past, cyanoacrylate-chamber-fuming necessitated that such items be completely unfolded to a flat state. Even then, over and under fuming was a very real possibility. Some portions might have been over-fumed while other portions might not have been fumed adequately. Latent fingerprints fumed within a vacuum have been found to collect glue deposits on the fingerprint ridge structures in a far more even manner than non-vacuum-fumed items. Over-fuming is, for the most part, a thing of the past. In addition, in a vacuum, the glue is distributed far more evenly throughout the chamber. Because of this, the fumes readily travel around corners and in and out of recesses of the item(s) being processed. In other words, it is possible to achieve well-distributed fingerprint development throughout the inside of a vacuum chamber. The **SIRCHIE**® No. VAC150 is a state-of-the-art vacuum chamber designed and built specifically for the fuming of crime scene objects of various shapes and sizes. The chamber interior is a generous 16" long with a 10" diameter. The heavy, 0.365" aluminum walls ensure structural integrity while being used. It features a heavy-duty, diaphragm-type pump controlled by a precision vacuum switch. The operation and use of the No. VAC150 is both straightforward and simple.

Specifications

Net Weight
Dimensions

44 lbs. (19.96 kg)
17" x 11 1/2" dia.
(43.2 cm x 29.2 cm dia.)

Leading Particulars

- End Cap Retention: Elastic T-handles
- Finish: Black wrinkle epoxy paint
- Materials: Aluminum and Lexan™
- Pump Shut Off: 15 inches of Hg
- Wall Thickness: 0.365 inch
- Rapid pumpdown
- Automatic shutoff and restart to maintain vacuum



No. VAC150 consists of:

- 1-No. VAC100 Vacuum Chamber for Cyanoacrylate Development, 17"
- 1-No. VAC50 Vacuum Pump, Diaphragm Type, 115 VAC

CATALOG NO.	CYANOVAC I LABORATORY FUMING CHAMBER	PRICE
VAC150	110V AC	\$995.00
VAC150220	220V AC	\$1,095.00

CYANOVAC II LABORATORY FUMING CHAMBER OUTFIT

The No. VAC250's vacuum chamber was designed for, but is not limited to, fuming rifles and shotguns under controlled vacuum conditions. Glue-fuming under vacuum improves latent fingerprint development in every way. It is not only faster, but the fumes are distributed far more evenly. Over-fuming is practically a thing of the past under vacuum. Fumes travel into crevices and around corners much more readily. Although the size of this chamber was engineered to accommodate rifles, it can be used to glue-fume literally anything that will fit, even items that are wrinkled and creased, such as plastic garbage bags. Constructed with heavy, 1/4" aluminum walls, the No. VAC250 is engineered to easily withstand years of demanding service. It is supplied with a matched, heavy-duty, diaphragm-type vacuum pump, release valve and gauge. This is a complete system—all that is needed is the glue and the suspect item!

Specifications

Net Weight
Dimensions

43.8 lbs. (19.84 kg)
48 3/4" x 9" dia.
(123.8 cm x 22.9 cm dia.)

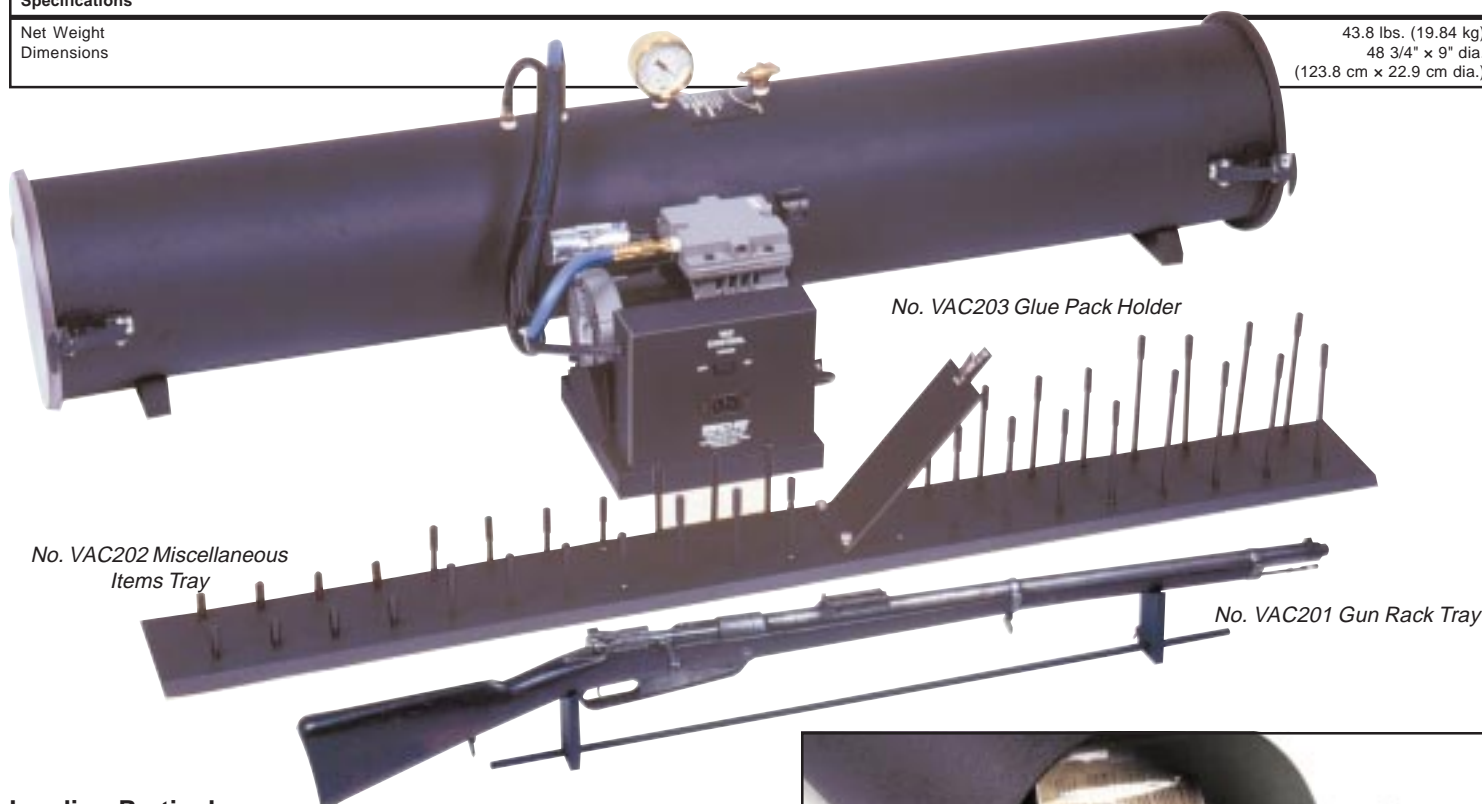

Leading Particulars

- End Cap Retention: Elastic T-handles
- Finish: Black wrinkle epoxy paint
- Materials: Aluminum and Lexan™
- Pump Shut Off: 15 inches of Hg
- Wall Thickness: 0.25"
- Rapid pumpdown
- Automatic shutoff and restart to maintain vacuum

No. VAC250 consists of:

- 1-No. VAC200 Vacuum Chamber for Cyanoacrylate Development, 48"
- 1-No. VAC201 Gun Rack Tray
- 1-No. VAC202 Miscellaneous Items Tray
- 1-No. VAC203 Glue Pack Holder
- 1-No. VAC50 Vacuum Pump, Diaphragm Type, 115 VAC

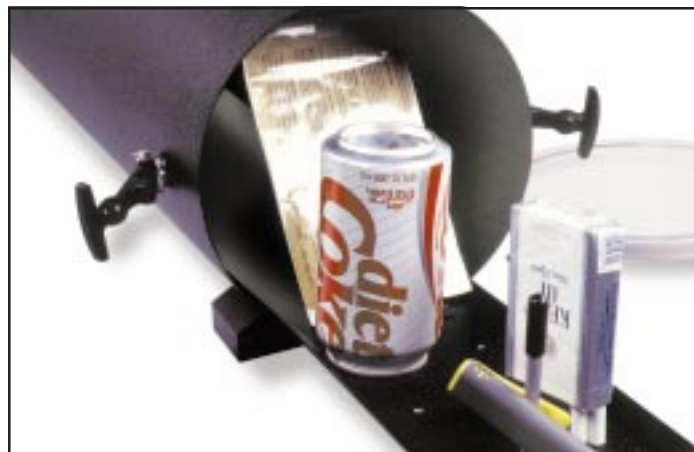

Evidence is placed on the CyanoVac II's miscellaneous item tray and inserted into the chamber for fuming.

CATALOG NO.	CYANOVAC II LABORATORY FUMING CHAMBER	PRICE
VAC250	110V AC	\$1,089.00
VAC250220	220V AC	\$1,189.00

LIFTING DEVELOPED LATENT FINGERPRINTS WHEN AND WHY

After developing latent fingerprints by utilizing any of the following methods:

- A. FINGERPRINT POWDERS, BOTH REGULAR, MAGNETIC AND FLUORESCENT
- B. SMALL PARTICLE REAGENT (SPR)
- C. CYANOACRYLATE (SUPER GLUE) THAT HAS BEEN ENHANCED WITH FINGERPRINT POWDER

The fingerprints should be photographed and then lifted from the surface on which they reside, for preservation and/or optical enhancement/comparison or computer database storage.

SIRCHIE® manufactures a wide choice of fingerprint lifting mediums for effecting this procedure.

AVAILABLE RESOURCES FOR LIFTING

1. **SEARCH**® Hinge Lifters (page 91)
2. **SEARCH**® LIFT-O-TABS™ and **SIRCH-LIFT**™ Tabs (pages 92-93)
3. **SEARCH**® Fingerprint Lifting Tapes (pages 94-95)
4. **SEARCH**® Rubber Lifters, Fingerprint and Palm Print (pages 96-97)
5. **SEARCH**® Liquid Rubber Lifters (page 97)

After lifting developed fingerprints, it is necessary to back up the lifting medium. This is accomplished with printed data cards of various standard formats or on blank, transparent or opaque backing sheets (coated paper or plastic). See pages 100-101 for standard products.

CHOOSING A LIFTER MEDIUM ...

Because latent fingerprints are found on almost every conceivable surface—regardless of shape or material—certain guidelines are recommended. A general selection table follows:

SURFACE TYPE AND EXAMPLE	LIFTER SELECTION	PAGE NO.
NONPOROUS FLAT SURFACES Metals (finished, coated), Smooth Plastics, Glass, Wood (finished, coated)	SEARCH ® Hinge Lifters SEARCH ® LIFT-O-TABS™ SEARCH ® Lifting Tape	91-95
NONPOROUS and POROUS IRREGULAR CONTOUR SURFACES	SEARCH ® Lifting Tape SEARCH ® Rubber Lifters	94-97
NONPOROUS GRAINED, FLAT AND IRREGULAR CONTOUR SURFACES	SEARCH ® Rubber Lifters	96-97
NONPOROUS, SOFT SUBSTANCES Clay, Putty, Etc.	SEARCH ® Liquid Rubber	97

SEARCH® FINGERPRINT HINGE LIFTERS



SELECTIONS



- FAST
 - EFFICIENT
 - ECONOMICAL
- the **SEARCH**® HINGE LIFTER

Since **SIRCHIE**® Finger Print Laboratories introduced the hinge lifter in the 1960s, it has become the standard for leading investigative agencies throughout the world. The hinge lifter draws its uniqueness from the fact that a special adhesive formulation permits optically clear viewing of latent prints years after lifting.

about **THE SEARCH[®] HINGE LIFTER ...**

The hinge lifter is a pre-assembled device that combines the lifting medium (acrylic adhesive on a 5 mil [.005"] clear acetate tab) and a backing sheet of either clear acetate or opaque vinyl. The hinge concept means that the lifter and backing material are a one-piece unit, ready to lift, seal and protect fragile latent fingerprints.

IMMEDIATE COMPARISONS

Immediate comparisons may be made with suspected prints. The print may be used directly for contact prints or enlargements. Foolproof: The lifter is marked with a * on the viewing side so that the print cannot be reversed in handling and the user always knows which side to view.

Lifter: .005 Mylar with special crystal clear adhesive surface

Cover: .010 Rigid vinyl black, white opaque or transparent acetate cover



1 1/2" x 2" HINGE LIFTERS

Sized for single fingerprint lifting

CATALOG NO.	BACKING COLOR	QUANTITY/BOX	PRICE/BOX
130LT	TRANSPARENT	24 EA.	\$7.75
130LW	WHITE	24 EA.	\$7.75
130LB	BLACK	24 EA.	\$7.75



2" x 4" HINGE LIFTERS

Sized for multiple fingerprints or partial palm prints

CATALOG NO.	BACKING COLOR	QUANTITY/BOX	PRICE/BOX
131LT	TRANSPARENT	12 EA.	\$6.75
131LW	WHITE	12 EA.	\$6.75
131LB	BLACK	12 EA.	\$6.75



4" x 4" HINGE LIFTERS

Sized for multiple fingerprints or full palm prints

CATALOG NO.	BACKING COLOR	QUANTITY/BOX	PRICE/BOX
131LT4	TRANSPARENT	12 EA.	\$7.75
131LW4	WHITE	12 EA.	\$7.75
131LB4	BLACK	12 EA.	\$7.75



SUPER HINGE LIFTER ASSORTMENTS

Super Hinge Lifter Assortment

- 16 ea. 1 1/2" x 2" Trans. 8 ea. 4" x 4" Trans. 8 ea. 2" x 4" Trans.
- 16 ea. 1 1/2" x 2" White 8 ea. 4" x 4" White 8 ea. 2" x 4" White
- 16 ea. 1 1/2" x 2" Black 8 ea. 4" x 4" Black 8 ea. 2" x 4" Black

CATALOG NO. 133LTWB PRICE: 29.75



POLICE SPECIAL ASSORTMENT

TRANSPARENT, BLACK OR WHITE

Consists of 48 ea. hinge lifters:

24 each: 1 1/2" x 2", 12 each: 2" x 4", 12 each: 4" x 4"

CATALOG NO.	DESCRIPTION	PRICE
132LT	TRANSPARENT	\$18.75
132LW	WHITE	\$18.75
132LB	BLACK	\$18.75

LATENT PRINT LIFTING PRODUCTS



SEARCH® LIFT-O-TABS™

SEARCH® LIFT-O-TABS™ are individual, pre-cut and scored transparent lifters made of .005" Mylar® that feature a clear adhesive for maximum clarity. Tabs are protected by peel-off covers that are made of polyester and scored for easy removal. Leave the lifter in place on the lifting surface to protect the latent print or peel the lifter off the surface and mount on a backing cover.

Leading Particulars

- Clear adhesive
- Tab identification for positive viewing
- Three convenient sizes
- Supplied in dust-free plastic boxes
- Plastic backing covers provided with each lifter

SEARCH® LIFT-O-TABS™ (1 1/2" x 2" SIZE)

These tabs are 1 1/2" x 2" and are packaged 24 to a box with 24 covers.



CATALOG NO.	BACKING COLOR	QUANTITY/BOX	PRICE
TLT01	TRANSPARENT	24 TABS & COVERS	\$6.75
TLT02	WHITE	24 TABS & COVERS	\$6.75
TLT03	BLACK	24 TABS & COVERS	\$6.75



SEARCH® LIFT-O-TABS™ (2" x 4" SIZE)

These tabs are 2" x 4" and are packaged 24 to a box with 24 covers.

CATALOG NO.	BACKING COLOR	QUANTITY/BOX	PRICE
TLT04	TRANSPARENT	24 TABS & COVERS	\$7.50
TLT05	WHITE	24 TABS & COVERS	\$7.50
TLT06	BLACK	24 TABS & COVERS	\$7.50



SEARCH® LIFT-O-TABS™ (4" x 4" SIZE)

These tabs are 4" x 4" and are packaged 12 to a box with 12 covers.

CATALOG NO.	BACKING COLOR	QUANTITY/BOX	PRICE
TLT07	TRANSPARENT	12 TABS & COVERS	\$7.75
TLT08	WHITE	12 TABS & COVERS	\$7.75
TLT09	BLACK	12 TABS & COVERS	\$7.75

SIRCH-LIFT™ TABS (LIFT-O-TABS™ on a roll)

SIRCH-LIFT™ TABS™ feature high-quality fingerprint lifters on a pre-cut and scored roll—packaged in a unique dispenser carton. The carton stores the tabs and dispenses them one-at-a-time. So they're ready to use anytime, anywhere without any backing material to remove. Lifters are 1 1/2" x 2" and packaged 100 to a carton.

- CONVENIENT
- CLEAN
- EFFECTIVE



SIRCH-LIFT™ TABS are dispensed on a roll, making them easy to use.

Leading Particulars

- Lifters are made of .005" (5 mil) thick clear acetate
- Acrylic adhesive is optically clear, free of "fish eyes" and streaks
- A .001" (1 mil) thick polyester liner covers the adhesive and serves as a dispenser mechanism
- Dispenser carton dispenses tabs one-at-a-time
- Tabs may be backed on any medium

CATALOG NO.	DESCRIPTION	PRICE
SLT100	LIFT-O-TABS™/100	\$16.50
SLT101	BLACK/WHITE BACKERS/100	\$4.25

SEARCH® LIFT-O-TABS™ COMBINATION

The **SEARCH®** LIFT-O-TABS™ combination features an assortment of LIFT-O-TABS™ to meet most latent print lifting requirements. Each combination is comprised of 108 lifters in the following sizes and quantities:

LIFTER QUANTITY	SIZE	BACKER QUANTITY	COLOR
16	1 1/2" x 2"	16	TRANSPARENT
16	1 1/2" x 2"	16	WHITE
16	1 1/2" x 2"	16	BLACK
12	2" x 4"	12	TRANSPARENT
12	2" x 4"	12	WHITE
12	2" x 4"	12	BLACK
8	4" x 4"	8	TRANSPARENT
8	4" x 4"	8	WHITE
8	4" x 4"	8	BLACK



CATALOG NO. TLT10 AS LISTED ABOVE (TOTAL 108 LIFTERS) PRICE: \$29.95

LATENT PRINT DEVELOPMENT PRODUCTS



FINGERPRINT LIFTING TAPES

MUST BE ...

- UNIFORM IN ADHESIVE COATING
- AIR-BUBBLE FREE
- CONTROLLED PRESSURE WOUND
- AIR FLOW, HEAT TREATED

SIRCHIE® TAPE EXCEEDS THE STANDARDS

SIRCHIE® LIFTING TAPES (ALL SIZES)

PROCEDURAL USE OF TAPES ...

1. After the latent print has been developed with powders and photographed, lifting should be accomplished.
2. Hold the loose end of the tape with the thumb and forefinger of one hand and the roll in the other.
3. Pull out enough tape to cover the area to be lifted (usually six to seven inches).
4. Secure the loose end of the tape beside the print or prints to be lifted and hold it there with the forefinger.
5. The thumb is then "slid" along the top of the tape, forcing it gently down over the print.
6. The roll being held in the other hand should not be released during this operation.
7. Using care, the tape should be smoothed down over the print, forcing out any air bubble entrapments, as the thumb moves toward the roll.

AFTER THE TAPE IS SECURED ...

1. If the surface on which the print is located would be destroyed by removing the tape, it should be left on and the article secured for transport from the field.
2. If the above is not the case, the powdered print may be removed by pulling up on the roll end.
3. When the tape is free of the surface it should be transferred to a backing card or other medium (See pages 100-101).
4. When secured, the tape should be cut from the roll and the loose end folded over. Tape dispensers (See page 95) are very desirable accessories when using lifting tape.



TRANSPARENT AND FROSTED LIFTING TAPES BY SIRCHIE®

Choose the appropriate finish and size of the finest lifting tapes available—only by **SIRCHIE®**. All sizes and finishes are pressure wound, heat treated and "fish-eye" free. After lifting the powdered prints the tape is easily mounted on rigid vinyl or coated paper backing sheets. See pages 100-101 for backing selection. All sizes are wound on standard 1" cores to fit **SIRCHIE®** lifting tape dispensers (See page 95).

CATALOG NO.	DESCRIPTION/SIZE	PRICE
144.5L	TRANSPARENT, 1" x 360"	\$3.25
144L	TRANSPARENT, 1 1/2" x 360"	\$4.50
144L2	TRANSPARENT, 2" x 360"	\$5.50
145.5L	FROSTED, 1" x 360"	\$3.25
145L	FROSTED, 1 1/2" x 360"	\$4.95
145L2	FROSTED, 2" x 360"	\$6.50

ONE-INCH TAPES ARE SUPPLIED IN DUST-FREE PLASTIC BAGS.

ONE AND A HALF-INCH AND TWO-INCH TAPES ARE SUPPLIED IN DUST-FREE PLASTIC JARS.

LIFTED PRINT BACKING CARDS—SEE PAGES 100 AND 101.



Lift palm prints or multiple fingerprints with **SIRCHIE**®'s palm/cluster fingerprint lifting tapes.

PALM/CLUSTER FINGERPRINT LIFTING TAPES

As their name implies, palm/cluster fingerprint lifting tapes are designed for lifting developed palm prints or cluster (multiple) fingerprints. The tape is available in transparent or frosted and is pressure-wound and heat-treated to eliminate imperfections and uneven adhesive. Available in two sizes, the tape is individually packaged in resealable plastic bags for dust protection.



CATALOG NO.	DESCRIPTION/SIZE	PRICE
144L3	TRANSPARENT, 3" x 360"	\$8.00
144L4	TRANSPARENT, 4" x 360"	\$9.25
145L3	FROSTED, 3" x 360"	\$8.75
145L4	FROSTED, 4" x 360"	\$9.75

SEARCH® POLYETHYLENE LIFTING TAPE (TRANSPARENT)

SEARCH® polyethylene lifting tape is the perfect choice for lifting developed, powdered latent prints from curved or irregular surfaces. Made of strong, elastic, transparent polyethylene, this tape adapts to textured, convex and concave surfaces, and is able to withstand strain without damaging prints. The lifting tape is available in a 1 1/2" width and a 2" width and is supplied in a dust-free plastic container.



Leading Particulars

- Flexible
- Elastic
- Not affected by extremes in temperature
- Non-distorting
- Excellent adhesion



SIRCHIE®'s No. 169PPA polyethylene lifting tape is perfect for lifting developed prints from curved or irregular surfaces.

CATALOG NO.	DESCRIPTION	PRICE
169PPA	1 1/2" x 360" TRANSPARENT	\$8.75
269PPB	2" x 360" TRANSPARENT	\$10.95

FINGERPRINT LIFTING TAPE DISPENSERS

SIRCHIE® tape dispensers provide a convenient method for holding, dispensing and cutting a variety of lifting tape sizes. The sharp, high-carbon steel, serrated cutting blades provide a clean cut—every time. Average weight is two ounces. Fabrication: Clear brushed, nickel-plated steel with integral cutting blade to accommodate one inch diameter core size.

CAT. NO.	DESCRIPTION/SIZE	PRICE
145TW	DISPENSER FOR 1" WIDE TAPE	\$7.25
146L	DISPENSER FOR 1 1/2" WIDE TAPE	\$7.50
146TW	DISPENSER FOR 2" WIDE TAPE	\$7.95
147TW	DISPENSER FOR 3" WIDE TAPE	\$8.75
148TW	DISPENSER FOR 4" WIDE TAPE	\$9.75



LATENT PRINT LIFTING PRODUCTS

SEARCH® RUBBER FINGERPRINT LIFTERS

SEARCH® rubber fingerprint lifters are among the best available. Used exclusively by some of the major investigation bureaus in the world, these lifters feature an exceptional adhesive face designed to pick up all powder traces from developed prints—without adhering to the lifting surface. This is true even if the surface is porous (such as paper). These lifters are especially useful for lifting developed prints off highly grained surfaces, as well as irregular and curved surfaces. Simply remove the protective, transparent acetate cover, lift the developed print and replace the cover for protection.



Apply SEARCH®'s rubber fingerprint lifters to an irregular surface, such as the one pictured above.



Prints are transferred to the lifter.

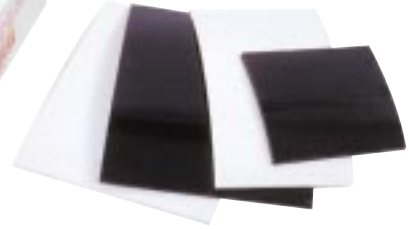

Leading Particulars

- Absolute duplication of developed print
- Low-density adhesive
- Quick recovery from irregular surfaces
- Excellent contour of conformity
- High-contrast black or white
- Ideal thickness: 1/16" (.062")

CATALOG NO.	DESCRIPTION/SIZE	QUANTITY	PRICE
126LW	WHITE, 2" x 2"	12	\$7.75
126LB	BLACK, 2" x 2"	12	\$7.75
127LW	WHITE, 2" x 4"	12	\$9.25
127LB	BLACK, 2" x 4"	12	\$9.25
128LW	WHITE, 3" x 4"	12	\$9.95
128LB	BLACK, 3" x 4"	12	\$9.95
129LW	WHITE, 4" x 10"	1	\$5.25
129LB	BLACK, 4" x 10"	1	\$5.25



An operator replaces the protective cover after lifting.

SEARCH® RUBBER PALM/CLUSTER LIFTERS

Use this lifter whenever powder-developed palm prints or clusters (multiple prints) need to be lifted from irregular or curved surfaces. The 7" x 9" size is ideal for lifting a full handprint. The lifters are supplied six to a package.

CATALOG NO. 125LW WHITE, 6 EACH PRICE: \$23.25

CATALOG NO. 125LB BLACK, 6 EACH PRICE: \$23.25

SEARCH® LIQUID RUBBER FINGERPRINT LIFTER KIT

SIRCHIE®'s liquid rubber lifter kit is used to lift latent prints—developed with powder—from surfaces that are wrinkled or creased, such as metal foils, plastic bags, and fabrics, that may be distorted by the pressure required using standard fingerprint lifters. Simply mix and pour the liquid rubber over the latent print and lift.

Liquid rubber is also recommended for making exact reproductions of fingerprint impressions that do not require powder development, such as those found in plastic materials such as caulking, putty and clay. Liquid rubber is supplied with the necessary mixing tools and complete instructions.

No. LRL123 consists of:

- 1- No. LRL4 Liquid Rubber Lifter, 4 oz.
- 1- No. STM1003 Modeling Clay, 1/4 lb.
- 5- No. CNA1061 Disposable Aluminum Mixing Containers
- 5- No. KCP202 Wood Spatulas, 4 1/2"
- 1- No. TM1.5 Silicon Rubber Catalyst, .5 fl. dr. (3.7 ml)
- 20- No. 130LT1 Transparent Hinge Lifters, 1 1/2" x 2"
- 1- No. LRL2 Black Molded Copolymer Case, 8 1/2" x 7 3/4" x 3 5/8"



CATALOG NO. LRL1234 PRICE \$49.95

SEARCH® TRANSPARENT PALM/CLUSTER LIFTERS

These 6" x 9" lifters are designed to accommodate palm or cluster (multiple) prints that are developed with powder on flat surfaces. The lifters are transparent and pre-assembled—featuring a clear acrylic adhesive on a .005" thick Mylar® sheet attached to a .010" thick transparent, black or white vinyl backing sheet. The lifters are packaged 12 to a box.



palm/cluster lifters

CATALOG NO.	BACKING COLOR	QUANTITY	PRICE
135LT	TRANSPARENT	12	\$21.95
135LW	WHITE	12	\$21.95
135LB	BLACK	12	\$21.95

RETRACTABLE LIFTER KNIFE

This is a pocket, pen-type knife for trimming fingerprint lifter materials, including rubber, Mylar®, acetate, and SEARCH® liquid rubber after setting. Made of anodized aluminum, the knife features a pocket clip and a replaceable blade. The knife dimensions are: 5.5" overall length; blade size: 5/16".



CATALOG NO. GL002 KNIFE W/ BLADE PRICE: \$12.25
CATALOG NO. GL012 5/16" REPLACEMENT BLADE PRICE: \$3.95

LATENT PRINT LIFTING PRODUCTS

SEARCH® WRITE-ON TAB HINGE LIFTERS

This lifter is a pre-assembled device that combines the lifting medium (acrylic adhesive on a .005" clear acetate tab) a backing sheet of clear acetate or opaque vinyl and the addition of an information write-on tab at the base of the assembly.

SIMPLIFIED APPLICATION

The write-on tab hinge lifter is constructed of .005" thick Mylar® to eliminate tab peeling—completely. The thickness helps to eliminate air pockets and distortion.

IMMEDIATE COMPARISONS

Immediate comparisons may be made with suspected prints and the print be used directly for contact prints or enlargements.

WRITE-ON TAB

Critical notations on the tab can be made and remain with the lifted evidence as an integral component.



An operator notates a lifted print on write-on hinge lifters.

CATALOG NO.	COLOR/SIZE	QTY./BOX	PRICE
LP130LB	BLACK, 1 1/2" x 2"	24 EA.	\$8.75
LP130LT	TRANSPARENT, 1 1/2" x 2"	24 EA.	\$8.75
LP130LW	WHITE, 1 1/2" x 2"	24 EA.	\$8.75
LP131LB	BLACK, 2" x 4"	12 EA.	\$7.75
LP131LT	TRANSPARENT, 2" x 4"	12 EA.	\$7.75
LP131LW	WHITE, 2" x 4"	12 EA.	\$7.75
LP131LB4	BLACK, 4" x 4"	12 EA.	\$8.75
LP131LT4	TRANSPARENT, 4" x 4"	12 EA.	\$8.75
LP131LW4	WHITE, 4" x 4"	12 EA.	\$8.75

HINGE LIFTERS/SUPER ASSORTMENT WITH WRITE-ON TAB

This assortment of hinge lifters covers "all the bases." Included are all the popular standard sizes with assorted black, white, and transparent backing covers. Each lifter has a write on tab as an integral part of the lifter assembly.



No. LP133LTWB consists of:

- 16- No. LP130LB1 Black, with Write-On Tabs, 1 1/2" x 2"
- 8- No. LP131LB1 Black, with Write-On Tabs, 2" x 4"
- 8- No. LP131LB41 Write-On Tabs, 4" x 4"
- 16- No. LP130LT1 Transparent, with Write-On Tabs, 1 1/2" x 2"
- 8- No. LP131LT1 Transparent, with Write-On Tabs, 2" x 4"
- 8- No. LP131LT41 Transparent, with Write-On Tabs, 4" x 4"
- 16- No. LP130LW1 White, with Write-On Tabs, 1 1/2" x 2"
- 8- No. LP131LW1 White, with Write-On Tabs, 2" x 4"
- 8- No. LP131LW41 White, with Write-On Tabs, 4" x 4"

CATALOG NO. LP133LTWB HINGE LIFTER SUPER ASSORTMENT \$30.75

RUBBER FOOTPRINT LIFTERS

The **SEARCH**® rubber footprint lifters are uniquely designed to allow for an accurate transfer of foot or footwear prints from dusty and/or dirty surfaces. They are particularly useful when dealing with lightly covered surfaces because they don't generate static electricity like standard lifting tapes. The rubber footprint lifters may be reused if they are properly cleaned and rejuvenated with **SIRCHIE**'s No. 647C101 rejuvenator cleaner spray. Two 6" x 15" rubber footprint lifters—one black and one white—and a bottle of rejuvenator cleaner spray are supplied with each order.

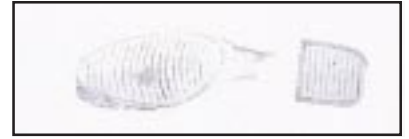

CATALOG NO. 647C100 COMPLETE AS DESCRIBED PRICE: \$26.50

REJUVENATOR CLEANER SPRAY

Rejuvenator cleaner spray is specifically formulated for cleaning **SIRCHIE**'s rubber footprint lifters. The spray is supplied in an eight-ounce amber glass bottle with a white plastic spray head.



CATALOG NO. 647C101 PRICE: \$11.00

PEEL AND LIFT TAPE PADS

Lifting latent prints is made easy with **SIRCHIE**'s peel and lift tape pads. Each pad features 25 pre-cut sheets of lifting tape, six inches in length. Each sheet is designed with its very own leader so that peeling and using the tape is a snap. The pads are available with a transparent or frosted finish, in a 2-inch width or a 4-inch width. Twenty-five black and white reversible backing covers are included.



Leading Particulars

- Convenient and extremely easy to use and peel
- Flat sheets minimize the chance of air bubbles
- Simple to transport and store
- Available in both clear and frosted
- Reversible backing cards (25 each)
- 25 individual lifters per pad

***SIRCHIE**'s peel and lift tape pads are easy to use. Simply pull back the leader and lift prints.*

CATALOG NO.	DESCRIPTION	PRICE
PL200	TRANSPARENT, PAD OF 25 WITH COVERS (6" x 2")	\$5.75
PL400	TRANSPARENT, PAD OF 25 WITH COVERS (6" x 4")	\$9.50
PL200F	FROSTED, PAD OF 25 WITH COVERS (6" x 2")	\$6.75
PL400F	FROSTED, PAD OF 25 WITH COVERS (6" x 4")	\$10.50

LATENT PRINT DEVELOPMENT PRODUCTS

SEARCH® LIFTED PRINT BACKING CARDS

Latent prints lifted with lifting tape are mounted on **SIRCHIE®**'s high-quality backing cards. **SIRCHIE®** offers an excellent selection of backing cards for use with any of the following products:

- 1) **SIRCHIE®** Lifting Tapes (all sizes)
- 2) **SEARCH®** LIFT-O-TABS™ (page 92)
- 3) **SIRCH-LIFT™** TABS (page 93)
- 4) Any transparent or frosted adhesive lifter

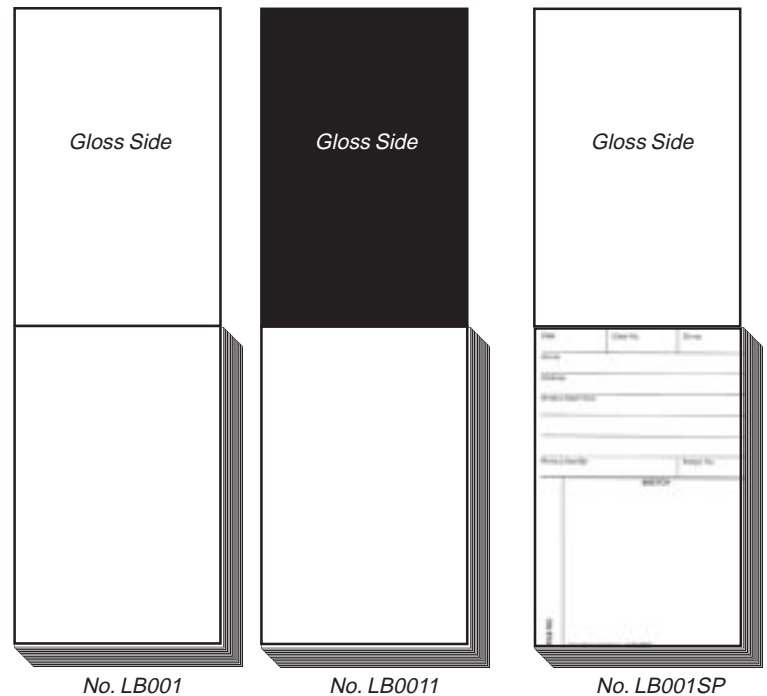

LIFTED PRINT BACKING SHEET PADS

SIRCHIE®'s lifted print backing sheet pads offer both economy and quality. Produced from high-quality, cast-coated card stock, 50 backing sheets are bound into pads with a tear-resistant cover that won't fall apart. Available in a "reversible" format (high-gloss black on one side, white on the other) and a high-gloss white format. Cards are .012" thick.



CATALOG NO.	DESCRIPTION	PAD SIZE	PRICE
LB001	GLOSS WHITE	5 1/2" x 8 1/2"	\$9.75
LB002	GLOSS WHITE	2 1/4" x 4"	\$7.75
LB003	GLOSS WHITE	3" x 5"	\$8.00
LB0011	GLOSS BLACK REVERSIBLE	5 1/2" x 8 1/2"	\$10.25
LB0021	GLOSS BLACK REVERSIBLE	2 1/4" x 4"	\$8.25
LB0031	GLOSS BLACK REVERSIBLE	3" x 5"	\$8.75
LB001SP	GLOSS WHITE/SKETCH CARD	5 1/2" x 8 1/2"	\$12.95

RIGID PLASTIC BACKING SHEET (VINYL)

SIRCHIE®'s rigid vinyl backing sheets are available in three sizes in white, black or transparent. Use the backing sheets with lifting tapes, LIFT-O-TABS™, or any other transparent or frosted lifter. They reduce the risk of damage to latent prints that may be caused by inadvertent folding of paper backing cards. These backing sheets are supplied with tissue paper intermediaries to prevent scratching of high-gloss finishes.

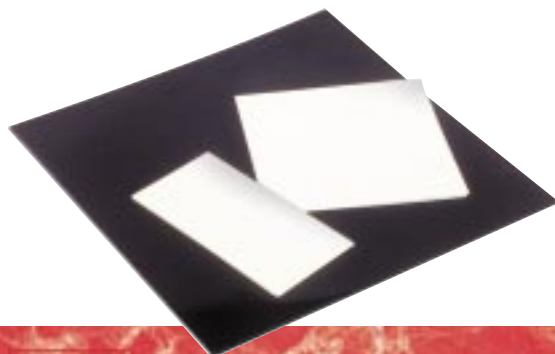

CATALOG NO.	COLOR	SIZE	QUANTITY	PRICE
LB201	WHITE	2" x 4"	30	\$10.50
LB202	BLACK	2" x 4"	30	\$10.50
LB203	TRANSPARENT	2" x 4"	30	\$10.50
LB204	WHITE	4" x 4"	20	\$13.75
LB205	BLACK	4" x 4"	20	\$13.75
LB206	TRANSPARENT	4" x 4"	20	\$13.75
LB207	WHITE	8" x 8"	20	\$21.50
LB208	BLACK	8" x 8"	20	\$21.50
LB209	TRANSPARENT	8" x 8"	20	\$21.50

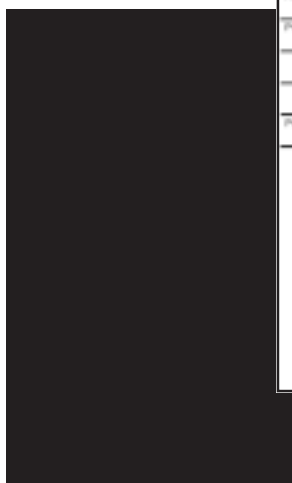

No. LPB100 (Back)

Date	Case No.	Crime
Victim		
Address		
Finger Lifted From		
Finger Lifted By		
Sketch No.		
SKETCH		
FILE NO.	Sirchie Finger Print Lab No. LPB100	

No. LPB100 (Front)

Date	Case No.	Crime
Victim		
Address		
Finger Lifted From		
Finger Lifted By		
Sketch No.		
SKETCH		
FILE NO.	Sirchie Finger Print Lab No. LPW100	

No. LPW100 (Front)



No. LPW100 (Back)

LIFTED PRINT BACKING/ SKETCH/RECORD CARDS

After latent prints are developed, they may be lifted and mounted on the cast-coated, high-gloss back side of **SIRCHIE**®'s lifted print backing/sketch/record cards. The front side of the 3" x 5" card is used for recording case information, including a rough sketch of the location of the latent prints. Two card formats are available: 1) A gloss **BLACK** back for light-color-powder lifts (No. LPB100). 2) A gloss **WHITE** back for dark-color-powder lifts (No. LPW100).

CATALOG NO.	DESCRIPTION	QUANTITY	PRICE
LPB100	GLOSS BLACK BACK	100	\$15.50
LPB1005	GLOSS BLACK BACK	500	\$61.75
LPW100	GLOSS WHITE BACK	100	\$15.50
LPW1005	GLOSS WHITE BACK	500	\$61.75

SEARCH® REVERSIBLE BACKING CARDS

The choice of many federal law enforcement agencies, this reversible backing card is produced from the finest quality, cast-coated paper stock. Cards feature a high-gloss, black finish on one side and a white, matte finish on the other side. Card dimensions: 3" x 5" x .012" thick.

CATALOG NO.	QUANTITY	PRICE
FC343	100	\$13.75
FC3431	500	\$54.50
FC3432	1000	\$92.95



COMBINATION BACKING/RECORD CARDS

These cards are designed primarily for use with single fingerprints, dusted with powder and lifted with 1", 1 1/2" or 2" lifting tape or LIFT-O-TABS™. Space is provided for recording pertinent crime scene data. Cards are available with black or white contrast area for prints. Card dimensions: 3" x 5" x .012" thick.

CATALOG NO.	LIFT AREA COLOR	QUANTITY	PRICE
FC337	BLACK	100	\$15.95
FC3375	BLACK	500	\$57.75
FC340	WHITE	100	\$13.75
FC3405	WHITE	500	\$54.50

NAME	TYPE	CODE	
ALIAS	RECORD NO.	FINGER	
FOUND AT			
DEVELOPED BY			
GENERAL F.P.O.			
SIRCHIE FINGER PRINT LAB. 1100-1100			LIGHT POWDER PRINT
DEVELOPED BY			
GENERAL F.P.O.			
SIRCHIE FINGER PRINT LAB. 1100-1100			
			DARK POWDER PRINT

INTRODUCTION LATENT PRINT FIELD KITS

Used by law enforcement agencies worldwide, **SIRCHIE**'s latent print field kits offer a combination of many of the most widely used latent print development products available. The products in these kits are of the highest quality and are designed to best accommodate the needs and requirements of crime scene investigators. The kits vary according to the numerous functions performed by crime scene investigators and range from the very modest to very complex. *However, SIRCHIE realizes that agencies have varying requirements and that kits must conform to the special needs of their investigators. SIRCHIE is prepared to assist your department in designing customized kits that provide your investigator with the supplies and materials which will make their work more efficient.*



PATROL LATENT PRINT KIT

This kit is ideal for the department whose patrol officer's responsibilities include crime scene investigation as well as regular patrol duties. It comes with complete instructions.

No. MFC100 consists of:

- 1-No. 101L Silk Black Latent Powder, 2 oz.
- 1-No. 145L2 Lifting Tape, 2" x 360"
- 1-No. 122L1 Kit Size Fiberglas® Brush
- 1-No. LB003 Backing Sheet Pad, 3" x 5", (50 sheets)
- 1-No. SF00771 Disposable Latex Glove, Pair
- 1-No. MFC100C Black Molded Copolymer Case
Dimensions: 8 1/2" x 7 3/4" x 3 5/8"
Weight: 1.7 lbs.

CATALOG NO. MFC100 PRICE: \$27.50



DETECTIVE POCKET LATENT KIT

This kit is an effective kit which fits comfortably in a shirt or coat pocket. It is used for on-the-spot latent print searches and development.

No. 157L consists of:

- 1-No. 101L4 Silk Black Latent Powder, 1/2 oz.
- 1-No. 103L4 Indestructible White Latent Powder, 1/2 oz.
- 1-No. SR301L4 Silver/Red Safecracker Latent Powder, 1/2 oz.
- 2-No. 131LT1 Transparent Hinge Lifters, 2" x 4"
- 2-No. 131LW1 White Hinge Lifters, 2" x 4"
- 2-No. 131LB1 Black Hinge Lifters, 2" x 4"
- 2-No. 118L Regular Powder Brushes
- 1-No. KCP112 Straight Handle Magnifier, 3X
- 1-No. 157LC Leatherette Zipper Case
Dimensions: 6 3/4" x 4" x 2"
Weight: 0.4 lbs.

CATALOG NO. 157L PRICE: \$24.50





SEARCH® LATENT PRINT TECHNICIAN KIT

This is a professional latent print development kit, rugged and produced from selected leather for durable service. This kit is the ideal choice for high-incident crime areas and is supplied with complete instructions.

No. 175L consists of:

- 1-No. 101L Silk Black Latent Powder, 2 oz.
- 1-No. 103L Indestructible White Latent Powder, 2 oz.
- 1-No. 144L Lifting Tape, 1 1/2" x 360"
- 6-No. 130LT1 Transparent Hinge Lifters, 1 1/2"
- 6-No. 130LW1 White Hinge Lifters, 1 1/2" x 2"
- 6-No. 130LB1 Black Hinge Lifters, 1 1/2" x 2"
- 2-No. 118L Regular Powder Brushes
- 1-No. KCP110 Scissors, 5"
- 1-No. 379M Attached Case Magnifier, 1 3/4"
- 1-No. SF00771 Latex Disposable Gloves, Pair
- 1-No. 175LC Black Molded Copolymer Case
Dimensions: 8 1/2" x 7 3/4" x 3 5/8"
Weight: 1.8 lb

CATALOG NO. 175L PRICE: \$36.25

SEARCH® SCOTT LATENT PRINT KIT

This professional latent print kit offers an increased selection of fingerprint powders along with an augmented selection of fingerprint lifters. It is a kit containing a desirable complement of components for those departments handling a wide range of crime scene situations. Each kit is supplied with complete instructions.

No. 176L consists of:

- 1- No. 101L Silk Black Latent Powder, 2 oz.
- 1- No. 103L Indestructible White Latent Powder, 2 oz.
- 1- No. SG202L Silver/Gray Latent Powder, 2 oz.
- 3- No. 118L Regular Powder Brushes
- 1- No. 130LT Transparent Hinge Lifters, 1 1/2" x 2", 24 each
- 12- No. 130LW1 White Hinge Lifters, 1 1/2" x 2"
- 12- No. 130LB1 Black Hinge Lifters, 1 1/2" x 2"
- 2- No.127LW1 White Rubber Lifters, 2" x 4"
- 2- No. 127LB1 Black Rubber Lifters, 2" x 4"
- 1- No. KCP110 Scissors, 5"
- 1- No. 379M Attached Case Magnifier, 1 3/4"
- 1- No. SF00771 Latex Disposable Gloves, Pair
- 6- No. ZTE022 Evidence Bags, 4" x 6"
- 6- No. EIL011 Crime Evidence Labels
- 1- No. 176LC Black Molded Copolymer Case
Dimensions: 8 1/2" x 7 3/4" x 3 5/8"
Weight: 2.3 lbs.



CATALOG NO.176L PRICE: \$43.95

LATENT PRINT DEVELOPMENT PRODUCTS



SEARCH® POWDER FOAM-AWAY

This product is used primarily for cleaning latent fingerprint powders from various surfaces after investigations. FOAM-AWAY will not harm any of the following surfaces: formica, varnished wood, painted surfaces, vinyl upholstery, glass, fabrics, carpeting or any metal surface. FOAM-AWAY does not contain ammonia or other harsh chemicals that are harmful to the skin. Excellent for cleaning kits of spilled powders. NON-FLUOROCARBON PROPPELLANT. Available in a 16-ounce aerosol can.

CATALOG NO. PC100 PRICE: \$14.50



SWEEPER MAGNETIC LATENT PRINT KIT

This is an excellent kit for sweeping large areas with magnetic fingerprint powder. It features a wide-sweep magnetic sweeper wand and three magnetic powders to cover any situation. Powders are supplied in wide-mouth containers for optimum sweeper access.

No. 160L consists of:

- 1-No. MSW114L Regular Black Magnetic Latent Print Powder Pack
 - 1-No. MSW200 Magnetic Sweeper Wand
 - 1-No. MSWBM10 Silver/Gray Magnetic Latent Print Powder Pack
 - 1-No. MSWSBM9 Silver/Black Magnetic Latent Print Powder Pack
 - 1-No. KC101 Molded Plastic Carrying Case with Component Inserts
- Dimensions: 14 3/8" x 7 1/4" x 7" and Weight: 4.4 lbs.

CATALOG NO. 160L PRICE: \$86.50



ADHESIVE SIDE POWDER KIT

This kit contains all the components necessary to develop latent prints on the adhesive surface of tapes, labels and similar surfaces. Adhesive-side powder yields excellent results on duct tape, plastic tapes (clear, frosted and opaque), paper labels and tapes (except those with water-activated adhesives), vinyl surgical tape (excellent fidelity but low contrast). **SIRCHIE®**'s No. ASP50UVP powder is ideal for vinyl or plastic black electrical tape. Use it with the ultraviolet lamp supplied. The No. TRA20 adhesive tape release agent allows tangled tape to be released without damage to latent prints which may be present. Complete instructions are included.

No. ASP150 consists of:

- 1-No. ASP50 Adhesive Side Powder, 50 g
- 1-No. ASP50UV UV Adhesive Side Powder, 25 g
- 1-No. ASP10 EZFLO Super Concentrate, 6 oz. (198 ml)
- 1-No. TRA20 Adhesive Tape Release Agent, 1 oz. (29 ml)

- 1-No. CUV100T Longwave Ultraviolet Light, DC
 - 4-No. KCP230 AA-Cell Batteries, Alkaline
 - 1-No. KCP300 LDPE Bottle with Cap, 6 oz. (198 ml)
 - 2-No. 118L Regular Powder Brushes
 - 2-No. KCP139 Plastic Tweezers
 - 1-No. KCP301 Rinse Basin/Kit Case
 - 2-No. KCP302 Mixing Bowl with Lid
 - 2-No. SF00771 Disposable Latex Glove Pairs
 - 1-No. KCP303 Measuring Spoon, 1 tsp. (5 ml)
 - 1-No. KCP304 Measuring Spoon, 0.15 ml
 - 1-No. TI3210 Instructions for No. ASP150 Use
 - 1-No. TI3211 Instructions for No. TRA20 Use
 - 1-No. ASP501 Texturized, Molded-Plastic Carrying Case
- Dimensions: 17 1/2" x 10 1/8" x 8 7/8"

CATALOG NO. ASP150 PRICE: \$99.50

SEARCH® SMALL PARTICLE REAGENT (SPR) KIT (FOR FIELD AND LABORATORY USE)

Small particle reagent is a suspension of fine molybdenum disulfide particles in a surface-active solution for light-colored surfaces and a white suspension for dark-colored surfaces. It adheres to the fatty constituents of latent fingerprints to form a gray or white deposit—depending on the reagent, and is a quick and simple latent print development process (recommended by the U.K. Home Office, Scientific Research and Development Branch). Each kit includes complete instructions.

SPR may be utilized on the following:

- All non-porous surfaces that are wet or dry
- Glass or gloss painted articles
- Polyethylene bags, etc.
- Waxed and plastic-coated paper and products
- Polystyrene and polycarbonate products
- Exteriors of automobiles
- Exterior windows or other points of entry
- All types of dry or wet cans, bottles, etc.

No. SPR300 consists of:

- 2- No. SPR1001 Dark Small Particle Reagent (SPR), 500 ml
- 2- No. SPR2001 White Small Particle Reagent (SPR), 500 ml
- 2- No. KCP220 Dispenser Spray Heads
- 2- No. KCP221 Bottles, Plastic for Rinse Water, 500 ml
- 3- No. SF00771 Disposable Latex Glove Pairs
- 1- No. 236T16 Spray Magic Cleaner, 16 oz.



- 1- No. 144L4 Transparent Lifting Tape, 4" x 360"
- 6- No. KCP238 Plastic Sheet, 4" x 10" x .010"
- 12- No. FPT2541 Cleaner Towelettes
- 1- No. 144L2 Transparent Lifting Tape, 2" x 360"
- 1- No. LB0011 Lifted Print Backing Pad, 5 1/2" x 8 1/2", (50 sheets)
- 1- No. KCP110 Scissors, 5"
- 1- No. KCP223 Towel Storage Box, Plastic
- 1- No. SPR3001 Texturized, Molded-Plastic Carrying Case
Dimensions: 17 1/2" x 10 1/8" x 8 7/8"
Weight: 11.2 lbs.

CATALOG NO. SPR300 PRICE \$89.95

IODINE FUMING KIT

The technique for iodine fuming is simple and will not interfere with subsequent processing, either powder or chemical. Iodine vapor is absorbed by latent fingerprint deposits when present and form a brown image. The developed print may be photographed, fixed or transferred to silver sheets. FUMETTE™ disposable iodine fuming guns make it possible to process any surface with iodine vapor anytime, anywhere.

No. LPF100 consists of:

- 8-No. DF201 FUMETTE™ Disposable Iodine Fuming Guns
- 8-No. DCA1 Iodine Print Enhancer Ampoules
- 2-No. SP501 Silver Transfer Plates, 2" x 2"
- 1-No. SP505 Silver Cleaner/Polish, 2 oz.
- 4-No. SF00771 Disposable Latex Glove Pairs
- 1-KCP226 Suction Cup Plate Holder
- 1-No. LPF1001 Texturized, Molded-Plastic Carrying Case
Dimensions: 14 1/4" x 8 1/4" x 7"
Weight: 2.6 lbs.



CATALOG NO. LPF100 PRICE \$76.50



No. PLP100 consists of:

Latent Print Powders

- 1- No. 101L Silk Black Latent Powder, 2 oz.
- 1- No. 103L Indestructible White Latent Powder, 2 oz.
- 1- No. SB201L Silver/Black Latent Powder, 2 oz.
- 1- No. SR301L Silver/Red Safecracker Latent Powder, 2 oz.

Latent Print Brushes

- 3- No. 122L1 Kit Size Fiberglas® Latent Print Brushes
- 3- No. 119L Spread Powder Brushes

PROFESSIONAL LATENT PRINT KIT

This field kit incorporates the latest in brush applicators for powders—and a selection of **SIRCHIE**®'s finest latent print powders. With this system, multiple colored powders may be used effectively with "no intermix," and it is cost effective and efficient. All the necessary support components are included to aid in producing the desired result—latent print development.

Fingerprint Lifters

- 1- No. 145L2 Lifting Tape, 2" x 360"
- 12- No. 130LT1 Transparent Hinge Lifters, 1 1/2" x 2"
- 6- No. 131LT1 Transparent Hinge Lifters, 2" x 4"
- 6- No. 131LW1 White Hinge Lifters, 2" x 4"
- 6- No. 131LB1 Black Hinge Lifters, 2" x 4"
- 6- No. 127LW1 White Rubber Lifters, 2" x 4"
- 6- No. 127LB1 Black Rubber Lifters, 2" x 4"
- 6- No. 131LT41 Transparent Hinge Lifters, 4" x 4"

Support Components

- 1- No. LB0031 Backing Sheet Pad, 3" x 5", (50 sheets)
- 1- No. 379M Attached Case Magnifier
- 1- No. KCP110 Scissors, 5"
- 3- No. SF00771 Disposable Latex Glove Pairs
- 10- No. ZTE011 Evidence Bags, 4" x 6"
- 10- No. EIL011 Crime Evidence Labels
- 1- No. PLP1001 Attache-Type, Molded Polypropylene, Carrying Case with Metal Frame and Machined Internal Component Pad
Dimensions: 18" x 13 1/4" x 5 3/8"
Weight: 8 lbs.

CATALOG NO. PLP100 PRICE: \$142.75



HUNTER LATENT PRINT KIT

This is a compact latent print kit for use at any crime scene. Integrity and cleanliness of the kit and components are assured through utilization of the **SIRCHIE**® Fiberglas® retractable brush. Components are nested in a high-density polyethylene carrying case.

No. KHC500 consists of:

- 1-No. 101L Silk Black Latent Powder, 2 oz.
- 1-No. 103L Indestructible White Latent Powder, 2 oz.
- 2-No. RFF200 Fiberglas® Retractable Brushes
- 1-No. 144L Lifting Tape, 1 1/2" x 360"
- 1-No. LB0021 Backing Sheet Pad, 2 1/4" x 4", (50 sheets)
- 1-No. KCP110 Scissors, 5"
- 1-No. 379M Attached Case Magnifier
- 2-No. SF00771 Disposable Latex Glove Pairs
- 1-No. KHC5001 Black Molded Copolymer Carrying Case, Textured
Dimensions: 12 1/4" x 9" x 3 7/8"
Weight: 2 lbs.

CATALOG NO. KHC500 PRICE: \$65.50

LATENT PRINT SEARCH® KIT

This is a complete, multi-purpose latent print development kit that includes the efficient retractable Fiberglas® brush for regular powder application and the standard magnetic wand for magnetic powder application. All the components are housed in a professional carrying case with pre-formed component placement for access and efficiency. It is an excellent choice for crime scene search teams.

No. LPS100 consists of:

- 1-No. 101L Silk Black Latent Powder, 2 oz.
- 1-No. 103L Indestructible White Latent Powder, 2 oz.
- 1-No. M114L Black Magnetic Latent Powder
- 1-No. M116L White Magnetic Powder
- 2-No. RFF200 Fiberglas® Retractable Brushes
- 1-No. 125L Standard Magnetic Applicator
- 1-No. LB0021 Backing Sheet Pad, 2 1/4" x 4", (50 sheets)
- 1-No. 144L Lifting Tape, 1 1/2" x 360"
- 6-No. 130LT1 Transparent Hinge Lifters, 1 1/2" x 2"
- 6-No. 130LW1 White Hinge Lifters, 1 1/2" x 2"
- 6-No. 130LB1 Black Hinge Lifters, 1 1/2" x 2"
- 1-No. KCP110 Scissors, 5"
- 1-No. 379M Attached Case Magnifier, 1 3/4" diameter
- 1-No. KCP114 Retractable Measuring Tape, 6 ft.
- 3-No. SF00771 Latex Disposable Glove Pairs



- 1- No. LPS1001 Attache-Type, Molded Polypropylene, Carrying Case with Metal Frame and Machined Internal Component Pad
Dimensions: 18" x 13 1/4" x 5 3/8"
Weight: 7.8 lbs.

CATALOG NO. LPS100 PRICE: \$109.50

FINDER III LATENT PRINT KIT

This is a versatile and effective latent print development kit. It includes **SIRCHIE®**'s unique self-contained powder and brush delivery system, the FACII®, for regular print development and **SIRCHIE®**'s magnetic powder and wand application system for magnetic print development. Complete instructions are included.

No. FLP100 consists of:

- 1-No. FAC101 Silk Black FACII® Powder/Brush Combination
- 1-No. FAC103 Indestructible White FACII® Powder/Brush Combination
- 1-No. M114L Black Magnetic Latent Powder
- 1-No. M116L White Magnetic Powder
- 1-No. 125L Standard Magnetic Applicator
- 1-No. 144L Lifting Tape, 1 1/2" x 360"
- 1-No. LB0021 Backing Sheet Pad, 2 1/4" x 4", 50 sheets
- 6-No. 130LT1 Transparent Hinge Lifters, 1 1/2" x 2"
- 6-No. 130LW1 White Hinge Lifters, 1 1/2" x 2"
- 6-No. 130LB1 Black Hinge Lifters, 1 1/2" x 2"
- 4-No. 131LT1 Transparent Hinge Lifters, 2" x 4"
- 4-No. 131LW1 White Hinge Lifters, 2" x 4"
- 1-No. KCP223 Hinged Polystyrene Box
- 4-No. 131LB1 Black Hinge Lifters, 2" x 4"
- 1-No. KCP110 Scissors, 5"
- 1-No. 379M Attached Case Magnifier, 1 3/4" diameter



- 1-No. KCP114 Retractable Measuring Tape, 6 ft.
- 3-No. SF00771 Latex Disposable Glove Pairs
- 1-No. FLP1001 Attache-Type, Molded Polypropylene, Carrying Case with Metal Frame and Machined Internal Component Pad
Dimensions: 18" x 13 1/4" x 5 3/8"
Weight: 7.4 lbs.

CATALOG NO. FLP100 PRICE: \$131.50

LATENT PRINT LIFTING PRODUCTS

MASTER EXPERT LATENT PRINT KIT

This **SIRCHIE**[®] kit is the culmination of the latent fingerprint processing section of this manual.

It offers the crime scene investigator all the methods of developing fingerprints available from **SIRCHIE**[®].

All of the necessary support equipment is included.

The components of this kit should enable the user to accomplish successful latent fingerprint development in the field or laboratory.



No. MEL500 consists of:

Regular Powder Processing

- 1- No. 101L Silk Black Latent Powder, 2 oz.
- 1- No. 103L Indestructible White Latent Powder, 2 oz.
- 1- No. SB201L Silver/Black Latent Powder, 2 oz.
- 1- No. SG202L Silver/Gray Latent Powder, 2 oz.
- 1- No. SR301L Silver/Red Safecracker Latent Powder, 2 oz.
- 2- No. 122L Fiberglas[®] Latent Print Brushes
- 5- No. 118L Regular Powder Brushes

Magnetic Powder Processing

- 1- No. M114L Black Magnetic Latent Powder
- 1- No. M116L White Magnetic Powder
- 1- No. SBM9 Silver/Black Magnetic Latent Powder
- 1- No. SBM10 Silver/Gray Magnetic Latent Powder
- 1- No. SBM12 Silver/Red Magnetic Latent Powder
- 1- No. 125L Standard Magnetic Applicator

Chemical Fuming Processing

- 6- No. CNA20001 FINDER[™] Cyanoacrylate Packets
- 4- No. DF201 FUMETTE[™] Disposable Iodine Fuming Guns
- 4- No. DCA1 Iodine Print Enhancers

Chemical Processing

- 1- No. NSI609 Ninhydrin Spray, 8 oz.
- 1- No. 205C Silver Nitrate Spray, 8 oz.
- 1- No. SPR1008 Small Particle Reagent (SPR) 250 ml

Fingerprint Lifting

- 1- No. 144L2 Transparent Lifting Tape, 2" x 360"
- 1- No. 145L2 Frosted Lifting Tape, 2" x 360"
- 12- No. 130LT1 Transparent Hinge Lifters, 1 1/2" x 2"
- 12- No. 130LW1 White Hinge Lifters, 1 1/2" x 2"
- 12- No. 130LB1 Black Hinge Lifters, 1 1/2" x 2"

- 4- No. 131LT41 Transparent Hinge Lifters, 4" x 4"
- 4- No. 131LW41 White Hinge Lifters, 4" x 4"
- 4- No. 131LB41 Black Hinge Lifters, 4" x 4"
- 2- No. 125LW1 White Rubber Palm Lifters, 7" x 9"
- 2- No. 125LB1 Black Rubber Palm Lifters, 7" x 9"
- 1- No. LB0011 Lifted Print Backing Pad, 5 1/2" x 8 1/2", (50 sheets)

Process Support Materials

- 1- No. 316M Magnifier, 2 1/2"
- 1- No. KCP115 Penlight, 2-AA, 1.5 volt
- 2- No. KCP231 AA Cell Batteries, Carbon Zinc
- 1- No. 601E Photo Evidence Rule Tape, 1" x 360"
- 1- No. 603E Evidence Identification Tape, 1" x 500"
- 1- No. KCP110 Scissors, 5"
- 1- No. KCP114 Retractable Measuring Tape, 6 ft.
- 1- No. KCP116 Notebook
- 1- No. KCP225 Water Dispensing Bottle, 8 oz.
- 4- No. KCP117 Disposable Towels, 4 ply
- 8- No. ZTE011 Evidence Bags, 4" x 6"
- 3- No. ZTE021 Evidence Bags, 9" x 12"
- 4- No. SF00771 Latex Disposable Glove Pairs
- 8- No. FPT2541 Ink Cleaner Towelettes
- 2- No. KCP224 Molded-Polypropylene Storage Containers, 10 3/8" x 4 5/8" x 1 11/16"

Carrying Case

- 1- No. MEL5001 Vinyl-Leatherette, Texturized, Customized Carrying Case with Nickel-Plated Steel Hardware
Dimensions: 20 7/8" x 13 3/4" x 9 1/2"
Weight: 19.4 lbs

CATALOG NO. MEL500 PRICE: \$329.50

MULTI-TASK FINGERPRINT INVESTIGATION KITS

SIRCHIE® offers various kit combinations and sizes so that agencies may make selections based on individual or investigative needs and requirements. The following 10 pages contain a selection of kits that will enable an investigator to efficiently process a crime scene by:

- 1. Locating, developing and lifting latent fingerprint evidence
- 2. Collecting and preserving latent fingerprint evidence
- 3. Recording and rolling fingerprints of suspects as well as those of people with authorized access to the crime scene (for elimination prints)

SEARCH® MASTER POCKET LATENT PRINT KIT

The **SEARCH®** master pocket latent print kit is a latent print kit with fingerprint elimination supplies.

No. SEC500 consists of:

- 1-No. 101L1 Silk Black Latent Powder, 1 oz.
- 1-No. SG202L1 Silver/Gray Latent Powder, 1 oz.
- 2-No. 118L Regular Powder Brushes
- 4-No. 131LT1 Transparent Hinge Lifters, 2" x 4"
- 4-No. 131LB1 Black Hinge Lifters, 2" x 4"
- 4-No. 131LW1 White Hinge Lifters, 2" x 4"
- 4-No. LPB1001 Black Backing/Sketch/Record Cards, 3" x 5"
- 4-No. LPW1001 White Backing/Sketch/Record Cards, 3" x 5"
- 1-No. FPT270A Elimination Fingerprint Form Pad (50 sheets)
- 1-No. PMP100 Micro Porelon® Pad
- 1-No. SEC5001 Leatherette Carrying Case with Zipper
- 1-No. 379M Attached Case Magnifier, 1 3/4" diameter
- 4-No. FPT2541 Ink Cleaner Towelettes
- 1-No. FPT2701 Black Molded Copolymer Carrying Case, Textured
Dimensions: 8 1/2" x 7 3/4" x 3 5/8"
Weight: 1.82 lbs.



CATALOG NO. SEC500 PRICE: \$50.95

SEARCH® MULTI-PROCESS LATENT PRINT KIT

The **SEARCH®** multi-process latent print kit is a complete, coat-pocket-sized latent print kit. As its name implies, this kit features supplies for processing latent prints utilizing regular and magnetic methods. A pocket mini Porelon® elimination pad is included for recording fingerprints at the scene of the crime.

No. SEC600 consists of:

- 1-No. SB201L1 Silver/Black Latent Powder, 1 oz.
- 1-No. 118L Regular Powder Brush
- 1-No. SBM91 Silver/Black Magnetic Latent Powder, 1 oz.
- 1-No. 125L Standard Magnetic Applicator
- 4-No. 131LT1 Transparent Hinge Lifters, 2" x 4"
- 4-No. 131LB1 Black Hinge Lifters, 2" x 4"
- 4-No. 131LW1 White Hinge Lifters, 2" x 4"
- 4-No. LPB1001 Black Backing/Sketch/Record Cards, 3" x 5"
- 4-No. LPW1001 White Backing/Sketch/Record Cards, 3" x 5"
- 1-No. FPT270A Elimination Fingerprint Form Pad (50 sheets)
- 1-No. PMP100 Micro Porelon® Pad
- 6-No. FPT2541 Ink Cleaner Towelettes
- 1-No. 379M Attached Case Magnifier, 1 3/4" diameter
- 1-No. SEC5001 Leatherette Carrying Case with Zipper
- 1-No. FPT2701 Black Molded Copolymer Carrying Case, Textured



Dimensions: 8 1/2" x 7 3/4" x 3 5/8"
Weight: 1.98 lbs.

CATALOG NO. SEC600 PRICE: \$54.95

LATENT PRINT LIFTING PRODUCTS

THE SEARCH® II LATENT PRINT KIT



Leading Particulars

- Preserving and identifying latent print evidence
- Field comparison and elimination
- Locating and developing latent prints

about THE KIT ...

This is the most complete, compact latent print field kit. This kit is complete with a "search" comparison and elimination book along with the compact Porelon® fingerprint pad. This combination kit permits the investigator to locate, develop, lift and preserve latent evidence plus take elimination fingerprints at the scene. **SIRCHIE**®'s best Fiberglas® brush is provided for each color of powder. Powder colors may be changed if desired. A large selection of fingerprint lifters is included. This kit is an excellent choice for those departments with crime scene search teams.

No. 177L consists of:

Powders and Brushes

- 1- No. 101L Silk Black Latent Powder, 2 oz.
- 1- No. 103L Indestructible White Latent Powder, 2 oz.
- 1- No. SG202L Silver/Gray Latent Powder, 2 oz.
- 3- No. 122L1 Kit Size Fiberglas® Latent Print Brushes

Lifting Materials

- 1- No. 130LT Transparent Hinge Lifters, 1 1/2" x 2", 24 each
- 12- No. 130LB1 Black Hinge Lifters, 1 1/2" x 2"
- 12- No. 130LW1 White Hinge Lifters, 1 1/2" x 2"
- 6- No. 131LT1 Transparent Hinge Lifters, 2" x 4"
- 6- No. 131LB1 Black Hinge Lifters, 2" x 4"
- 6- No. 131LW1 White Hinge Lifters, 2" x 4"
- 2- No. 127LW1 White Rubber Lifters, 2" x 4"
- 2- No. 127LB1 Black Rubber Lifters, 2" x 4"

Evidence Collection Materials

- 1- No. FPT267 Porelon® Fingerprint Pad
- 1- No. FPT270A Elimination Fingerprint Form Pad (50 sheets)
- 1- No. 379M Attached Case Magnifier, 1 3/4" dia.
- 1- No. 603E Evidence Collection Tape, 1" x 500"
- 6- No. 621E1 Evidence Preserver Bags, 4" x 9"
- 9- No. FPT2541 Ink Cleaner Towelettes
- 1- No. FPT2701 Wallet-Type Vinyl Case
- 1- No. 177L1 Black Molded Copolymer Carrying Case, Textured
Dimensions: 12 1/4" x 9" x 3 7/8"
Weight: 3.7 lbs.

CATALOG NO. 177L PRICE: \$98.50

SEARCH® ALL-PURPOSE POLICE FIELD KIT



An operator records fingerprints with the cardholder mounted on the No. LP301A's carrying case.

Leading Particulars

- Compact size
- Replaceable components
- Ink slab or Porelon® fingerprint recording options
- Lightweight, rugged carrying case

about THE KIT ...

This is one of the most popular kits in the **SIRCHIE®** line. It is designed to meet the high standards required by today's police departments. This kit contains all the necessary materials for conducting investigations at the crime scene. A cardholder is mounted on the outside. Well-designed location of the contents permits the inclusion of materials for taking, developing, lifting, identifying and preserving evidence without a large case requirement. The carrying case is built for rugged use with reinforced steel corners.

Kits consist of:

Latent Fingerprint Developing and Lifting

- 1- No. 101L1 Silk Black Latent Powder, 1 oz.
- 1- No. 103L1 Indestructible White Latent Powder, 1 oz.
- 1- No. SB201L1 Silver/Black Latent Powder, 1 oz.
- 1- No. SG202L1 Silver/Gray Latent Powder, 1 oz.
- 1- No. SR301L1 Silver/Red Safecracker Latent Powder, 1 oz.
- 5- No. 118L Regular Powder Brushes
- 4- No. DF201 FUMETTE™ Disposable Fuming Guns
- 4- No. DCA1 Iodine Print Enhancers
- 1- No. 144L Transparent Lifting Tape, 1 1/2" x 360"
- 6- No. 131LT1 Transparent Hinge Lifters, 2" x 4"
- 6- No. 131LB1 Black Hinge Lifters, 2" x 4"
- 6- No. 131LW1 White Hinge Lifters, 2" x 4"
- 10- No. FC3371 Black Combination Backing Cards
- 10- No. FC3401 White Combination Backing Cards

Fingerprint Taking

- 1- No. FPT205 Glass Inking Slab, 4" x 10" (LP301A only)
- 1- No. FPT264M Fingerprint Cardholder, Mounted
- 1- No. FPR200 Unified Ink Roller, 2" (LP301A only)

- 1- No. 230T Fingerprint Ink, 2 oz. (LP301A only)
- 10- No. FPT2541 Ink Cleaner Towelettes
- 10- No. FC3301 Fingerprint Record Cards, 8" x 8"
- 1- No. FPT267 Porelon® Fingerprint Pad (LP301B only)

Evidence Collection and Identification

- 1- No. 316M Magnifier, 2 1/2" Dia.
- 1- No. KCP115 Penlight, 2 AA, 1.5 Volt
- 2- No. KCP231 AA-Cell Batteries, Carbon Zinc
- 1- No. KCP114 Retractable Measuring Tape, 6 ft.
- 1- No. 603E Evidence Identification Tape, 1" x 500"
- 3- No. EPS30W1 Photo Evidence Rulers, 6"
- 1- No KCP110 Scissors, 5"
- 1- No. KCP116 Notebook
- 1- No. SF00771 Latex Disposable Gloves, Pair
- 6- No. 621E1 Evidence bags, 4" x 9"

Case

- 1- No. LP3011 Attache-Type, Molded Polypropylene, Carrying Case with Metal Frame and Machined Internal Component Pad
Dimensions: 18" x 13 1/4" x 5 3/8"
Weight: 9.7 lbs. (LP301A) and 8.8 lbs. (LP301B)

CATALOG NO. LP301A INK SLAB AND ROLLER OPTION (AS PICTURED) PRICE: \$163.50
CATALOG NO. LP301B PORELON® OPTION PRICE: \$164.50

LATENT PRINT LIFTING PRODUCTS



SEARCH® BURGLARY SQUAD KIT



The No. LP304 features an exterior-mounted cardholder.

Leading Particulars

- Magnetic and regular powders
- Porelon® fingerprint taking
- Replacement components
- Lightweight, rugged carrying case

about THE KIT ...

The **SEARCH®** burglary squad kit is a multi-purpose latent print investigation kit for crime scene burglary specialists. Components permit rapid search and development of latent prints. Regular and magnetic powders are included. And a fingerprint cardholder is mounted externally to the kit's carrying case.

No. LP304 consists of:

Latent Fingerprint Developing and Lifting

- 1- No. 101L Silk Black Latent Powder, 2 oz.
- 1- No. SG202L Silver/Gray Latent Powder, 2 oz.
- 2- No. 118L Regular Powder Brushes
- 1- No. M114L Black Magnetic Latent Powder
- 1- No. SBM10 Silver/Gray Magnetic Latent Powder
- 1- No. 125L Standard Magnetic Applicator
- 6- No. 131LT1 Transparent Hinge Lifters, 2" x 4"
- 6- No. 131LB1 Black Hinge Lifters, 2" x 4"
- 6- No. 131LW1 White Hinge Lifters, 2" x 4"
- 4- No. 127LW1 White Rubber Lifters, 2" x 4"
- 4- No. 127LB1 Black Rubber Lifters, 2" x 4"
- 1- No. 144L Transparent Lifting Tape, 1 1/2" x 360"
- 10- No. FC3371 Black Combination Backing Cards
- 10- No. FC3401 White Combination Backing Cards
- 1- No. LB0031 Reversible Backing Sheet Pad, (50 sheets)

Fingerprint Taking

- 1- No. FPT267 Porelon® Fingerprint Pad
- 1- No. FPT264M Fingerprint Cardholder, Mounted
- 10- No. FPT2541 Ink Cleaner Towelettes

- 1- No. FPT2701 Wallet-Type Vinyl case
- 1- No. FPT270A Elimination Fingerprint Form Pad (50 sheets)
- 10- No. FC3301 Fingerprint Record Cards, 8" x 8"

Evidence Collection and Identification:

- 1- No. 316M Magnifier, 2 1/2" dia.
- 1- No. KCP115 Penlight, 2 AA, 1.5 Volt
- 2- No. KCP231 AA-Cell Batteries, Carbon Zinc
- 1- No. KCP114 Retractable Measuring Tape, 6 ft.
- 1- No. 603E Evidence Identification Tape, 1" x 500"
- 3- No. EPS30W1 Photo Evidence Ruler, 6"
- 1- No. KCP110 Scissors, 5"
- 1- No. KCP116 Notebook
- 1- No. SF00771 Disposable Latex Gloves, Pair
- 6- No. 621E1 Evidence Bags, 4" x 9"

Case

- 1- No. LP3041 Attache-Type, Molded Polypropylene, Carrying Case with Metal Frame and Machined Internal Component Pad
- Dimensions: 18" x 13 1/4" x 5 3/8"
Weight: 9.5 lbs.

CATALOG NO. LP304 PRICE: \$175.50

**SEARCH® SIGNAT
FINGERPRINT INVESTIGATION KIT**



Leading Particulars

- Porelon® crime scene access fingerprinting
- Lightweight, rugged attache carrying case
- Magnetic and regular latent powders
- Replaceable components

about **THE KIT ...**

The **SEARCH®** signat fingerprint investigation kit is an outstanding professional latent print value. This kit offers an excellent selection of regular and magnetic latent print powders. It also includes a Porelon® pad and elimination booklet for recording elimination prints at the crime scene. Supplies are stored in the kit's lightweight, durable, attache-type carrying case. The carrying case features expandable file folders for storing reports and other documents. Complete instructions are included.

No. SLP900 consists of:

Latent Fingerprint Developing and Lifting

- 1- No. 101L Silk Black Latent Powder, 2 oz.
- 1- No. 103L Indestructible White Latent Powder, 2 oz.
- 1- No. SB201L Silver/Black Latent Powder, 2 oz.
- 1- No. SG202L Silver/Gray Latent Powder, 2 oz.
- 4- No. 118L Regular Powder Brushes
- 2- No. 122L Fiberglas® Latent Print Brushes
- 1- No. M114L Black Magnetic Latent Powder
- 1- No. SBM9 Silver/Black Magnetic Latent Powder
- 1- No. SBM10 Silver/Gray Magnetic Latent Powder
- 1- No. 125L Standard Magnetic Applicator
- 1- No. 130LT Transparent Hinge Lifters, 1 1/2" x 2", 24 each
- 4- No. 131LT1 Transparent Hinge Lifters, 2" x 4"
- 4- No. 131LB1 Black Hinge Lifters, 2" x 4"
- 4- No. 131LW1 White Hinge Lifters, 2" x 4"
- 1- No. 144L Transparent Lifting Tape, 1 1/2" x 360"
- 1- No. LB0021 Reversible Backing Sheet Pad, (50 sheets)

- 1- No. FPT270A Elimination Fingerprint Form Pad (50 sheets)
- 10- No. FPT2541 Ink Cleaner Towelettes
- 1- No. FPT2701 Wallet-Type Vinyl Case

Evidence Collection and Identification

- 1- No. 316M Magnifier, 2 1/2" dia.
- 1- No. KCP115 Penlight, 2 AA, 1.5 Volt
- 2- No. KCP231 AA-Cell Batteries, Carbon Zinc
- 1- No. 603E Evidence Identification Tape, 1" x 500"
- 1- No. KCP114 Retractable Measuring Tape, 6 ft.
- 1- No. KCP110 Scissors, 5"
- 1- No. SF00771 Disposable Latex Gloves, Pair
- 10- No. 621E1 Evidence Bags, 4" x 9"

Case

- 1- No. SLP9001 Attache-Type, Molded Polypropylene, Carrying Case with Metal Frame and Machined Internal Component Pad
Dimensions: 18" x 13 1/4" x 5 3/8"
Weight: 10.9 lbs.

Fingerprint Elimination (Crime Scene Access)

- 1- No. FPT267 Porelon® Fingerprint Pad

CATALOG NO. SLP900 PRICE: \$185.95

LATENT PRINT LIFTING PRODUCTS



SEARCH®

LATENT PRINT FINDER KIT

about THE KIT ...

This is one of **SIRCHIE®**'s most popular latent print development kits. It is an excellent choice for departments with crime scene search teams. It is a complete kit with components for developing latent prints with regular or magnetic powders. A Porelon® pad, comparison and elimination record book and a generous supply of fingerprint lifters and backing cards are included. The latent powder brushes are Fiberglas® filament. Ample room is included for accessories.

Leading Particulars

- Regular latent and magnetic powders
- Porelon® crime scene access fingerprinting
- Fiberglas® filament brushes • Replaceable components
- Inner module accessory case
- Rugged carrying case • Machined internal component pad

No. LPS800 consists of:

Latent Fingerprint Developing and Lifting

- 1- No. 101L Silk Black Latent Powder, 2 oz.
- 1- No. 103L Indestructible White Latent Powder, 2 oz.
- 1- No. 107L Copper Metallic Latent Powder, 2 oz.
- 1- No. SB201L Silver/Black Latent Powder, 2 oz.
- 1- No. SG202L Silver/Gray Latent Powder, 2 oz.
- 5- No. 122L Fiberglas® Latent Print Brushes
- 1- No. M114L Black Magnetic Latent Powder
- 1- No. M116L White Magnetic Latent Powder
- 1- No. SBM9 Silver/Black Magnetic Latent Powder
- 1- No. 125L Standard Magnetic Applicator
- 1- No. 130LT Transparent Hinge Lifters, 1 1/2" x 2", 24 each
- 6- No. 131LB1 Black Hinge Lifters, 2" x 4"
- 6- No. 131LW1 White Hinge Lifters, 2" x 4"
- 6- No. 127LW1 White Rubber Lifters, 2" x 4"
- 6- No. 127LB1 Black Rubber Lifters, 2" x 4"
- 1- No. 131LT4 Transparent Hinge Lifters, 4" x 4", 12 each
- 1- No. 144L Transparent Lifting Tape, 1 1/2" x 360"
- 1- No. 145L Frosted Lifting Tape, 1 1/2" x 360"
- 1- No. LB0021 Reversible Backing Sheet Pad (50-sheets)

Fingerprint Elimination (Crime Scene Access)

- 1- No. FPT267 Porelon® Fingerprint Pad
- 10- No. FPT2541 Ink Cleaner Towelettes
- 1- No. FPT270A Elimination Fingerprint Form Pad (50 sheets)
- 1- No. FPT2701 Wallet-Type Vinyl Case

Evidence Collection and Identification

- 1- No. 316M Magnifier, 2 1/2" dia.
- 1- No. KCP115 Penlight, 2 AA, 1.5 Volt
- 2- No. KCP231 AA-Cell Batteries, Carbon Zinc
- 1- No. 603E Evidence Identification Tape, 1" x 500"
- 1- No. KCP114 Retractable Measuring Tape, 6 ft.
- 1- No. KCP110 Scissors, 5"
- 1- No. SF00771 Disposable Latent Gloves, Pair
- 1- No. KCP116 Notebook
- 12- No. ZTE101 Chain of Possession Labels
- 12- No. 608E/1 Evidence Tags with Ties
- 8- No. 620E1 Evidence Bags, 3" x 5"
- 8- No. 621E1 Evidence Bags, 4" x 9"
- 8- No. 622E1 Evidence Bags, 8" x 12"

Case

- 1- No. LPS8002 Texturized Polypropylene Accessory Case
- 1- No. LPS8001 Attache-Type, Molded Polypropylene, Carrying Case with Metal Frame and Machined Internal Component Pad
Dimensions: 18" x 13 1/4" x 5 3/8"
Weight: 10.9 lbs.

CATALOG NO. LPS800 PRICE: \$219.50

SEARCH® CRIME SCENE LATENT PRINT KIT

Leading Particulars

- Multiple methods of latent print development
- Replaceable components • Iodine processing with Iodettes™
 - Ninhydrin spray
- Porelon® crime scene access fingerprinting
 - Magnetic and regular latent powder
- Multiple methods of latent print development
 - Rugged attache carrying case



The **SEARCH®** crime scene latent print kit, No. CS800, is pictured with its components in place.

about **THE KIT ...**

The **SEARCH®** crime scene latent print kit is an exceptional kit designed for developing latent prints at the crime scene. Ninhydrin spray and Iodettes™ are included in the kit. Supplies are housed in the kit's texturized, polypropylene carrying case that features an expandable file folder for storing reports and other documents. Complete instructions are included.

No. CS800 consists of:

Latent Fingerprint Developing and Lifting

- 1- No. 101L Silk Black Latent Powder, 2 oz.
- 1- No. 103L Indestructible White Latent Powder, 2 oz.
- 1- No. SB201L Silver/Black Latent Powder, 2 oz.
- 2- No. 118L Regular Powder Brushes
- 2- No. 122L Fiberglas® Latent Print Brushes
- 1- No. M114L Black Magnetic Latent Powder
- 1- No. SBM10 Silver/Gray Magnetic Latent Powder
- 1- No. 125L Standard Magnetic Applicator
- 1- No. 202C Ninhydrin Spray, 6 oz. aerosol
- 1- No. AMP2066 Iodette™ Ampoules, 6 each
- 3- No. DCA1 Iodine Enhancement Applicators
- 3- No. ZTE021 Iodette™ Fuming Bags, 9" x 12"
- 1- No. 130LT Transparent Hinge Lifters, 1 1/2" x 2", 24 each
- 4- No. 131LT1 Transparent Hinge Lifters, 2" x 4"
- 4- No. 131LB1 Black Hinge Lifters, 2" x 4"
- 4- No. 131LW1 White Hinge Lifters, 2" x 4"
- 1- No. 144L Transparent Lifting Tape, 1 1/2" x 360"
- 1- No. LB0021 Reversible Backing Sheet Pad (50-sheets)

Fingerprint Elimination (Crime Scene Access)

- 1- No. FPT267 Porelon® Fingerprint Pad

- 1- No. FPT270A Elimination Fingerprint Form Pad (50 sheets)

- 10- No. FPT2541 Ink Cleaner Towelettes
- 1- No. FPT2701 Wallet-Type Vinyl Case

Evidence Collection and Identification

- 1- No. 379M Attached Case Magnifier, 1 3/4" dia.
- 1- No. KCP115 Penlight, 2 AA, 1.5 Volt
- 2- No. KCP231 AA-Cell Batteries, Carbon Zinc
- 1- No. 603E Evidence Identification Tape, 1" x 500"
- 1- No. KCP114 Retractable Measuring Tape, 6 ft.
- 1- No. KCP110 Scissors, 5"
- 1- No. SF00771 Disposable Latex Gloves, Pair
- 10- No. 621E1 Evidence Bags, 4" x 9"

Case

- 2- No. KCP152 Molded Polypropylene Cases, 8 1/2" x 4 1/2" x 1 3/4"
- 1- No. CS8001 Attache-Type, Molded Polypropylene, Carrying Case with Metal Frame and Machined Internal Component Pad
Dimensions: 18" x 13 1/4" x 5 3/8"
Weight: 11.3 lbs.

CATALOG NO. CS800..... PRICE: \$196.95



about **THE KIT ...**

This is one of **SIRCHIE®**'s finest, most complete latent print investigation kits. It is a professional kit containing all the latest, state-of-the-art components. Complete instructions on all the facets of latent print investigation are furnished. It is an excellent kit for all investigative branches of law enforcement agencies.

No. LP303A consists of:

Latent Fingerprint Powders

- 1- No. 101L Silk Black Latent Powder, 2 oz.
- 1- No. 103L Indestructible White Latent Powder, 2 oz.
- 1- No. SB201L Silver/Black Latent Powder, 2 oz.
- 1- No. SG202L Silver/Gray Latent Powder, 2 oz.
- 1- No. SR301L Silver/Red Safecracker Latent Powder, 2 oz.
- 1- No. M114L Black Magnetic Latent Powder
- 1- No. M116L White Magnetic Latent Powder
- 1- No. SBM9 Silver/Black Magnetic Latent Powder
- 1- No. SBM10 Silver/Gray Magnetic Latent Powder

Latent Print Chemical Developers

- 1- No. 202C Ninhydrin Spray, 6 oz. aerosol
- 4- No. DF201 FUMETTE™ Iodine Fuming Guns
- 4- DCA1 Iodine Print Enhancers
- 1- No. AMP2066 Iodette™ Ampoules, 6 each
- 4- No. CNA20001 FINDER™ Cyanoacrylate Packets

Latent Print Applicators and Equipment

- 5- No. 118L Regular Powder Brushes
- 2- No. 122L Fiberglas® Latent Print Brushes
- 1- No. 125L Standard Magnetic Applicator
- 1- No. 123LB Black Marabou Feather Duster
- 1- No. 123LW White Marabou Feather Duster
- 2- No. SP501 Silver Transfer Plates, 2" x 2"
- 1- No. KCP226 Suction Cup Plate Holder
- 1- No. SP505 Silver Cleaner/Polish, 2 oz.

Latent Print Lifting Materials

- 4- No. 131LT1 Transparent Hinge Lifters, 2" x 4"
- 4- No. 131LB1 Black Hinge Lifters, 2" x 4"
- 4- No. 131LW1 White Hinge Lifters, 2" x 4"
- 6- No. 127LW1 White Rubber Lifters, 2" x 4"

- 6- No. 127LB1 Black Rubber Lifters, 2" x 4"
- 1- No. 144L2 Transparent Lifting Tape, 2" x 360"
- 1- No. LB0021 Reversible Backing Sheet Pad (50 sheets)
- 10- No. LPB1001 Backing/Sketch/Black Cards, 3" x 5"
- 10- No. LPW1001 Backing/Sketch/White Cards, 3" x 5"

Fingerprint Taking Equipment

- 1- No. FPT267 Porelon® Fingerprint Pad
- 1- No. FEL101N Fingerprint Cardholder
- 1- No. FPT270A Elimination Fingerprint Form Pad (50 sheets)
- 10- No. FPT2541 Ink Cleaner Towelettes
- 20- No. FC3301 Fingerprint Record Cards, 8" x 8"
- 1- No. FPT2701 Wallet-Type Vinyl Case

Postmortem Equipment

- 1- No. PM283 Porelon® Postmortem Inking Tool
- 1- No. PMNS60 Postmortem Cardholder
- 1- No. PMFS500 Postmortem Finger Straightener
- 10- No. FC345R1 Postmortem Record Cards
- 10- No. FC345L1 Postmortem Record Cards

Evidence Collection and Identification

- 1- No. 317M Fingerprint Magnifier, 3" dia.
- 1- No. KCP115 Penlight, 2 AA, 1.5 Volt
- 2- No. KCP231 AA-Cell Batteries, Carbon Zinc
- 1- No. 603E Evidence Identification Tape, 1" x 500"
- 1- No. KCP114 Retractable Measuring Tape, 6 ft.
- 3- No. EPS30W1 Photo Evidence Rulers
- 1- No. KCP110 Scissors, 5"
- 2- No. SF00771 Disposable Latex Glove Pairs
- 1- No. 600E Photo Evidence Rule Tape
- 1- No. KCP116 Notebook
- 12- No. 621E1 Evidence Bags, 4" x 9"
- 8- No. 622E1 Evidence Bags, 8" x 12"
- 1- No. 611E Black Evidence Marker
- 1- No. KCP145 White China Marker

Case

- 1- No. LP303A1 Leatherette-Covered Professional Carrying Case with Steel-Reinforced Corners, and Hardware and Storage Compartments for Supplies
Dimensions: 24 1/4" x 14 3/4" x 7"
Weight: 21.4 lbs.

CATALOG NO. LP303A..... PRICE: \$439.50

SEARCH® MASTER LATENT PRINT INVESTIGATION KIT

This kit is the most complete kit of its kind. It features supplies for every method of processing crime scenes for latent prints, including the finest selection of fingerprint powders, both regular and magnetic, and an excellent selection of brushes. The kit is comprised of four separate, removable kits which may be used remotely from the main kit—for greater mobility and efficiency. Store the kit in a car trunk when necessary—it's the modular concept to crime scene processing by **SIRCHIE®**



No. MLP2020A consists of:

Regular Latent Print Powder Equipment

1-No. FAC1000 FACII® +2 Kit which consists of:

1-No. FAC10001 Custom-Molded Carrying Case

1-No. FAC101 Silk Black FACII® Powder/Brush Combination

1-No. FAC103 Indestructible White FACII® Powder/Brush Combination

4-No. 131LT1 Transparent Hinge Lifters, 2" x 4"

4-No. 131LB1 Black Hinge Lifters, 2" x 4"

4-No. 131LW1 White Hinge Lifters, 2" x 4"

12-No. 130LT1 Transparent Hinge Lifters, 1 1/2" x 2"

1-No. 101L Silk Black Latent Powder, 2 oz.

1-No. 103L Indestructible White Latent Powder, 2 oz.

1-No. SB201L Silver/Black Latent Powder, 2 oz.

1-No. SG202L Silver/Gray Latent Powder, 2 oz.

1-No. SR301L Silver/Red Safecracker Latent Powder, 2 oz.

1-No. CBG203L Coin Box/Galvanic Latent Powder, 2 oz.

1-No. 118L Regular Powder Brush

2-No. 122L Fiberglas® Latent Print Brushes

2-No. CFB100 Carbosmoove™ I Brushes

Magnetic Latent Print Powder Equipment

1-No. 159L Regular Magnetic Latent Print Kit which consists of:

1-No. M114L Black Magnetic Latent Powder

1-No. M116L Gray Magnetic Powder

1-No. M117L White Magnetic Powder

1-No. SBM9 Silver/Black Magnetic Latent Powder

1-No. 125L Standard Magnetic Applicator

1-No. KC100 Molded Plastic Carrying Case with Component Inserts

Chemical Latent Print Development Materials

1-No. NSI609 Special Formula Ninhydrin Spray, 8 oz.

1-No. SLPS300 Silver Latent Print Spray, 8 oz.

4-No. DF201 FUMETTE™ Iodine Fuming Guns

4-No. DCA1 Iodine Print Enhancers

4-No. CNA20001 FINDER™ Cyanoacrylate Packets

Latent Print Lifting Materials

1-No. 145L Frosted Lifting Tape, 1 1/2" x 360"

1-No. 144L Transparent Lifting Tape, 1 1/2" x 360"

1-No. 144L4 Transparent Lifting Tape, 4" x 360"

1-No. 130LT Transparent Hinge Lifters, 1 1/2" x 2" (24 each)

1-No. 131LT Transparent Hinge Lifters, 2" x 4" (12 each)

1-No. LB0021 Reversible Backing Sheet Pad (50 sheets)

1-No. LRL1234 Liquid Rubber Fingerprint Lifter Kit which consists of:

1-No. LRL4 Liquid Rubber Lifter, 4 oz.

1-No. STM1003 Modeling Clay, 1/4 lb.

5-No. CNA1061 Disposable Aluminum Mixing Containers

5-No. KCP202 Wood Spatulas, 4 1/2"

1-No. TM1.5 Silicone Rubber Catalyst, .5 fl. dr. (3.7 ml)

20-No. 130LT1 Transparent Hinge Lifters, 1.5" x 2"

1-No. LRL2 Molded Copolymer Case, 8" x 6 1/2" x 3 1/2"

Fingerprint Taking and Elimination Materials

1-No. EFP90 Crime Scene Fingerprint Elimination Kit which consists of:

1-No. FPT267 Porelon® Fingerprint Pad

1-No. FPT270A Elimination Pad (50 sheets)

24-No. FPT2541 Ink Cleaner Towelettes

1-No. EFP901 Zipper-Type, Simulated-Leather Carrying Case

1-No. FPT2701 Wallet-Type Vinyl Case

Miscellaneous Support Materials

1-No. 317M Fingerprint Magnifier, 3" dia.

2-No. KCP231 AA-Cell Batteries, Carbon Zinc

1-No. KCP115 Penlight, 2 AA, 1.5 Volt

1-No. 600E Photo Evidence Rule Tape

1-No. 603E Evidence Identification Tape, 1" x 500"

1-No. KCP114 Retractable Measuring Tape, 6 ft.

3-No. EPS30W1 Photo Evidence Rulers

1-No. KCP110 Scissors, 5"

2-No. SF00771 Disposable Latex Glove Pairs

1-No. KCP116 Notebook

12-No. 621E1 Evidence Bags, 4" x 9"

8-No. 622E1 Evidence Bags, 8" x 12"

1-No. 611E Black Evidence Marker

1-No. KCP145 White China Marker

1-No. EFP901 Zipper-Type, Simulated-Leather Carrying Case

1-No. KCP224 Texturized Polypropylene Accessory Case

Case

1-No. MLP2020A1 Professional, Leatherette-Covered Carrying Case w/Steel-Reinforced Corners and Hardware
Dimensions: 24 3/8" x 11 1/2" x 16 7/8"
Weight: 25.4 lbs.

CATALOG NO. MLP2020A..... PRICE: \$479.75

MILITARY SPECIFICATION KITS

about THE KITS ...

THESE KITS ARE DESIGNED AND DEVELOPED SPECIFICALLY FOR MILITARY APPLICATIONS. THEY ARE MANUFACTURED AND ASSEMBLED ACCORDING TO FEDERAL SPECIFICATION NO. GG-F-355A.

TYPE II BURGLARY FINGERPRINT I.D. KIT

This kit is designed specifically for finding, developing and lifting print evidence at the crime scene.



No. 355TYPE2 consists of:

- 1- No. 101L Silk Black Latent Powder, 2 oz.
- 1- No. 102L Silk Gray Latent Powder, 2 oz.
- 1- No. M114L Black Magnetic Latent Powder
- 1- No. M117L Gray Magnetic Powder
- 1- No. 118L Regular Powder Brush
- 1- No. 122L Fiberglas® Latent Print Brush
- 1- No. 125L Standard Magnetic Applicator
- 1- No. LB003 Backing Sheet Pad, 3" x 5", 50 sheets
- 1- No. 130LT Transparent Hinge Lifters, 1 1/2" x 2" (24)
- 1- No. 130LB Black Hinge Lifters, 1 1/2" x 2" (24)
- 1- No. 131LT Transparent Hinge Lifters, 2" x 4"

- 1- No. 130LW White Hinge Lifters, 1 1/2" x 2" (24 each)
- 1- No. 131LB Black Hinge Lifter, 2" x 4"
- 1- No. 131LW White Hinge Lifters, 1 1/2" x 2", 24 each
- 3- No. 621E1 Bags, 4" x 9" x .003"
- 1- No. KCP139 Pair of Tweezers
- 1- No. KCP243 Screwdriver
- 1- No. KCP115 Penlight, 2AA 1.5 volt
- 1- No. KCP244 Envelope, #7 White Coin
- 2- No. KCP242 Soft Toothbrushes
- 1- No. KCP245 Pocket Knife
- 2- No. KCP231 AA-Cell Batteries, Carbon Zinc
- 1- No. KCP110 Pair of Scissors, 5"
- 1- No. KCP246 Tape Measure, 10 ft.
- 1- No. 144L Transparent Lifting Tape
- 1- No. 131LW4 White Hinge Lifters, 4" x 4"
- 1- No. 131LB4 Black Hinge Lifters, 4" x 4"
- 6- No. 127LW1 Rubber Latent Print Lifter, White
- 6- No. 127LB1 Rubber Latent Print Lifter, Black
- 20- No. FC3431 Backing Cards, Black and White, 3" x 5"
- 10- No. FC3301 Fingerprint Record Cards
- 1- No. 316M 2X Magnifier, 2 1/2" dia.
- 1- No. FPT264M Cardholder
- 1- No. 603E Tape PSA Evidence Labeling, 1" x 500"
- 1- No. 600E Rule PSA Tape Photo Evidence, 1/2" x 360"
- 10- No. FPT2541 Ink Cleaner Towelettes
- 1- No. KCP224 Texturized Polypropylene Accessory Case
- 1- No. MILII-A Attache-Type, Molded Polypropylene, Carrying Case with Metal Frame and Machined Internal Component Pad, 18" x 13 1/4" x 5 3/8"

Weight: 10.3 lbs.

PRICE: \$227.95

CATALOG NO. 355TYPE2

TYPE III POSTMORTEM FINGERPRINT I.D. KIT

This kit is designed specifically for preparing and recording fingerprints of the dead.

No. 355TYPE3 consists of:

- 1- No. 316M 2.5X Magnifier, 2 1/2" dia.
- 8- No. KRL103D Tissue Builder Solution, 1/2 oz.
- 1- No. KRL1062 Tissue Builder Solvent, 2 oz.
- 1- No. 634CID Silicone Solution, 2 oz.
- 1- No. TM1 Silicone Catalyst, 1/2 oz.
- 1- No. PM283 Postmortem Tool (pad)
- 2- No. KRL1052 Finger Tissue Cleaner
- 1- No. PMNS60 Postmortem Record Strip Holder
- 12- No. FC345L1 Postmortem Card, Left Hand
- 12- No. FC345R1 Postmortem Card, Right Hand
- 15- No. KCP217 Cotton Balls
- 3- No. 621E1 Bags, 4" x 9" x .003"

- 1- No. KCP139 Pair of Tweezers
- 4- No. SF00771 Pairs of Disposable Latex Gloves
- 2- No. KCP242 Soft Toothbrushes
- 2- No. KCP231 AA Cell Batteries, Carbon Zinc
- 4- No. KCP148 Syringes, 3 cc Disposable
- 1- No. KCP115 Penlight, 2AA, 1.5 Volt
- 10- No. KCP117 Disposable Towels, 4-Ply
- 1- No. KCP152 Molded Polypropylene Case, 8 1/2" x 4 1/2" x 1 3/4"
- 1- No. MILIIIA Attache-Type, Molded Polypropylene, Carrying Case with Metal Frame and Machined Internal Component Pad, 18" x 13 1/4" x 5 3/8"

Weight: 8.2 lbs.

PRICE: \$182.95

CATALOG NO. 355TYPE3



ADVANCED RESPONSE KIT

The NYPD5 was designed to meet the needs of the investigator at the scene of the crime. Some crime scenes don't lend themselves to being processed with conventional fingerprint powder methods. The kit is complete with a variety of chemical processing equipment as well as a disposable fuming chamber.

No. NYPD5 consists of:

- 1-No. NS1609 Special Formula Ninhydrin Spray with Spray Pump
 - 1-No. DF2016 Fumette Disposable Iodine Fuming Gun, 8 oz.
 - 1-No. SCW100 Cyanowand Fingerprint Kit
 - 1-No. FA100 Disposable Fuming Combination
 - 2-No. SCW4001 Hulk Cyanowand Cartridges
 - 1-No. LVS600 Ardrex After Fuming Fluorescent Dye Spray, 500 mL
 - 1-No. DCA16 Iodine Print Enhancer, 6 each
 - 1-No. CUV100T UV Mini Light Longwave, DC only
 - 1-No. SPR1001 Small Particle Reagent, Dark
 - 1-No. SPR2001 Small Particle Reagent, White
 - 1-No. SPR400UVI Small Particle Reagent, Fluorescent
 - 1-No. NYPD51 Professional, Leatherette-Covered Carrying Case with Steel-Reinforced Corners and Hardware
- Dimensions: 21 1/2" x 16 1/2" x 6 1/2"
Weight: 18.9 lbs.



The kit contains a variety of chemical processing equipment which includes **SIRCHIE**®'s special formula ninhydrin (which virtually eliminates ink from running), disposable iodine fuming guns, the **SIRCHIE**® cyanowand, plus dyes and enhancers. An added feature is a disposable fuming chamber to assist in processing evidence. The entire kit is housed in a leatherette-covered carrying case.

CATALOG NO. NYPD5 ADVANCED RESPONSE KIT PRICE: \$495.00

LATENT PRINT DEVELOPMENT PRODUCTS

EVIDENCE TECHNICIAN KIT 1

The EKT1 was designed to assist the evidence technician with basic latent print/evidence collection when at the crime scene. The kit has a wide variety of latent print powders, both regular and magnetic, to accommodate the many different surfaces a technician may encounter. The kit is complete with cyanoacrylate, iodine and small particle reagent. The kit allows the technician to locate, process, collect and package all relevant evidence at the crime scene.



No. ETK1 consists of:

Powders and Brushes

- 3- No. 123L Marabou Feather Brushes, White
- 1- No. 103L Hi-Fi Volcano Latent Print Powder, Indestructible White, 2 oz.
- 1- No. 101L Hi-Fi Volcano Latent Print Powder, Silk Black, 2 oz.
- 1- No. SB201L Hi-Fi Latent Print Powder, Silver/Black, 2 oz.
- 1- No. LL701 REDescent Fluorescent Latent Print Powder, 2 oz.
- 1- No. LL703 GREENescent Fluorescent Latent Print Powder, 2 oz.
- 3- No. 122L1 Kit Size Fiberglass Brushes
- 1- No. M115L Magnetic Latent Print Powder, Midnight Black
- 1- No. M116L Magnetic Latent Print Powder, White
- 1- No. 125L Permanent Magnetic Wand

Lifting Materials

- 1- No. 144L Fingerprint Lifting Tape, Transparent, 1 1/2" x 360"
- 1- No. 144L2 Fingerprint Lifting Tape, Transparent, 2" x 360"
- 1- No. FC343 Reversible Backing Card, 100 each

Chemical Processing

- 1- No. AMP2066 Iodette Ampoule, 3 gm., 6 each
- 1- No. DCA16 Iodine Print Enhancer, 6 each
- 1- No. CNA102 Cyanoacrylate Fuming Compound, 20 gm.
- 1- No. SPR1001 Small Particle Reagent, Dark 500 ml

Process Support Materials

- 1- No. KCP139 Plastic Tweezers
- 1- No. KCP138 Plastic Scalpel
- 1- No. GL000 Carbide Tip Scriber
- 1- No. KCP114 Retractable Measuring Tape, 6 ft.
- 1- No. KCP115 Penlight, 2 AA, 1.5 Volt
- 2- No. KCP231 AA-Cell Batteries, Carbon
- 1- No. KCP110 Scissors, 5"
- 1- No. 318M Magnifier, 2X, 3 1/2 dia.
- 1- No. CUV100T UV Mini-Light, Longwave, DC only
- 4- No. KCP230 AA-Cell Batteries, Alkaline

Packaging Accessories

- 1- No. SM1000 SIRCHMARK Evidence Tape, Red, "Evidence," 1 1/2" x 648"
- 5- No. IEB40001 Integrity Evidence Bags, 4" x 7 1/2"
- 5- No. IEB75001 Integrity Evidence Bags, 7 1/2" x 10 1/2"
- 5- No. IEB12001 Integrity Evidence Bags, 12" x 15 1/2"
- 5- No. EB001P1 Kraft Evidence Bags, Printed, 7" x 4 1/2" x 13 3/4"
- 5- No. EB002P1 Kraft Evidence Bags, Printed, 8" x 5" x 18"

Carrying Case

- 1- No. KCP152 Molded Polypropylene Inner Storage Case, Dimensions: 8 3/8" x 4 1/2" x 1 11/16"
- 1- No. EKTII Attache-Type, Molded Polypropylene, Carrying Case with Metal Frame and Machined Internal Component Pad
Dimensions: 18" x 13 1/4" x 5 3/8"
Weight: 15 lbs.

CATALOG NO. ETK1 EVIDENCE TECHNICIAN I KIT PRICE: \$325.00



BLUEMAXX™

PORTABLE FORENSIC ILLUMINATION SOURCE

BLUEMAXX™ systems are portable illumination sources capable of causing certain materials of forensic interest—including physiological fluids (such as urine, semen and saliva), certain drugs, such as crack cocaine, and materials treated with certain powders and dyes to fluoresce, or give off light. They are especially useful as tools for locating evidence for subsequent collection and analysis through area searches at the crime scene.

BLUEMAXX™ is basically a high-quality flashlight which has been outfitted with a very high-efficiency reflector and a set of filters. This combination turns the flashlight into a surprisingly efficient forensic tool. **BLUEMAXX™** systems work with any potential evidence having excitation bands between approximately 390 nanometers and 520 nanometers.

***BLUEMAXX™** systems are essential in area searches for evidence at the crime scene and excellent for the photography of evidence after location.*

There are a number of factors which will affect the outcome of the search. First is whether or not the material or evidence being searched for is luminescent when exposed to light from the **BLUEMAXX™**, or whether it can be made so by chemical reaction. Not all substances are capable of luminescence—those that require excitation by specific wavelengths of light. Light of the wrong wavelength makes no contribution to the excitation of the specimen or to its luminescence. Fortunately, many substances of primary interest at the crime scene do luminesce when exposed to radiation such as provided by **BLUEMAXX™**. Additionally, many non-luminescent and weakly luminescent substances, such as blood and palmar oils, may be made luminescent by bonding luminescent agents (fluorochromes) to them. This latter technique is the basis for use of fluorescent powder, dyes, DFO (1,8-Diazafluoren-9-one), and luminol to locate blood spots.

Recognizing the importance of dedicated crime scene search tools, **SIRCHIE®** offers **BLUEMAXX™** systems complete with light source, excitation filter and barrier filter.

SECTION III TABLE OF CONTENTS

BLUEMAXX™

Portable Illumination Products

Accessories	129
Barrier Filters	129
Barrier Filter Glasses	129
Barrier Filter Goggles	129
BLUEMAXX™ Latent Specialist Kit	127
BLUEMAXX™ Master Kit	128
BLUEMAXX™ Lights	121-124
BLUEMAXX™ Light Kits	127-128
BLUEMAXX™ Photography	125-126
BLUEMAXX™ Patrol Kit	127
Camera Filters	129
Excitation Filters	129
Forensic Photography	126
Photographic Illumination Kit	125
Rechargeable Forensic Light	122
Standard Forensic Light	121
SUPER BLUEMAXX™	124
System 600 Forensic Light	123

ANATOMY OF A
BLUEMAXX™ FORENSIC LIGHT

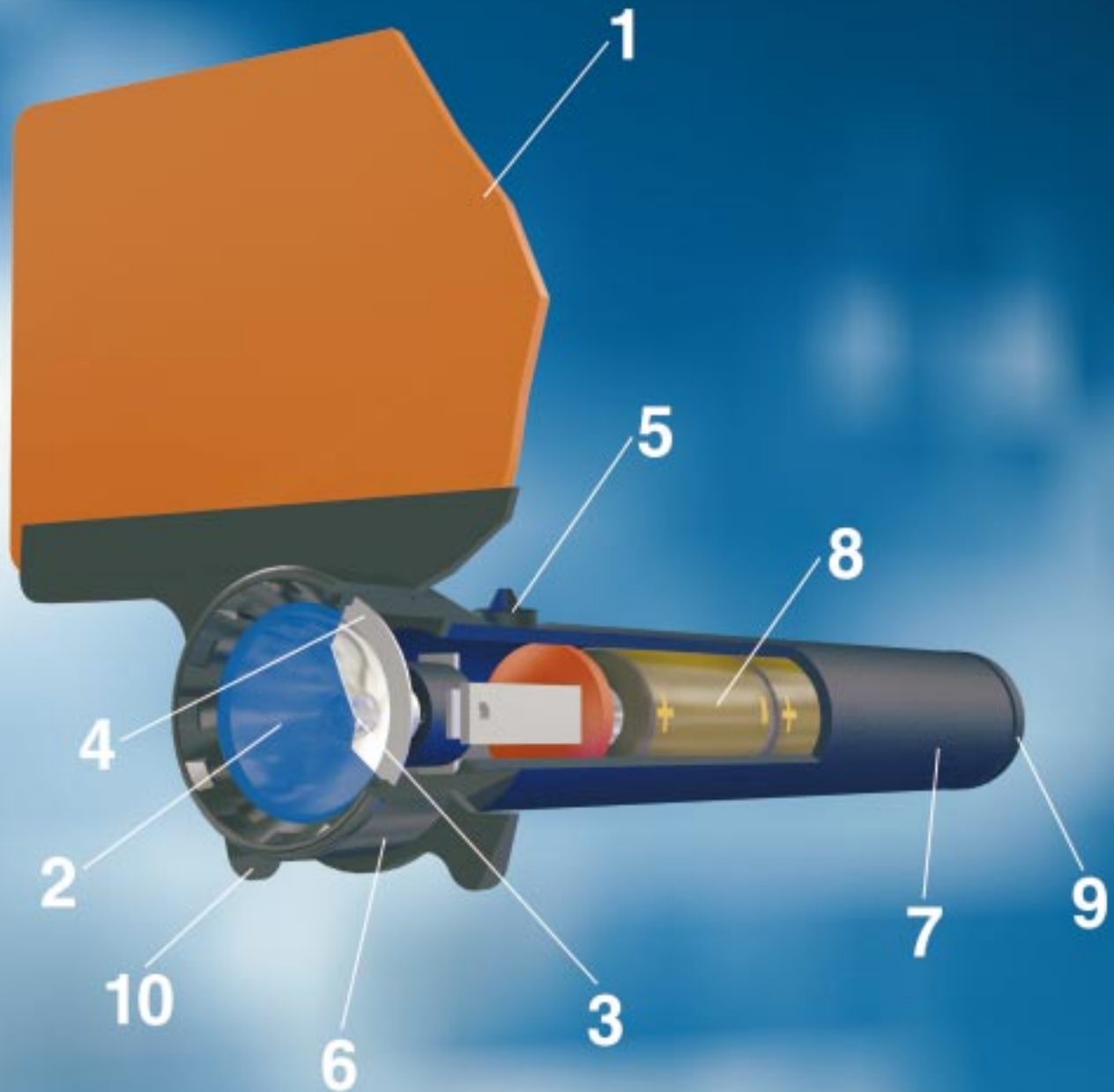

1. Longwave pass barrier filter—
550 nm edge
2. Excitation filter—
390 nm-520 nm passband
3. Krypton lamp
4. High efficiency reflector

5. Power on/off/momentary switch
6. ABS face cap and head assembly
7. Tough knurled ABS housing
8. Three D-cell high energy batteries
9. Battery cap with O-ring seal
10. Built-in steady rest

BLUEMAXX™ BM300 STANDARD FORENSIC LIGHT

The **BLUEMAXX™** forensic light, No. BM300, is pictured right, and below in its carrying case.



No. BM300

Specifications:

Bulb Type: Krypton, high intensity, 3.7-volt, 2.6-watt

Reflector: Parabolic, calibrated for 5"-8" spot at 10 feet

Beam Pattern: Spot

Maximum Output: 3.2 spherical candlepower

Length: 13.5" (343 mm)

Weight With Battery: 1 lb. 9 oz.

Switch: SPST combination momentary and alternate action

Battery Requirement: 3 alkaline "D" cells

Case Composition (flange): Cyclocac-T grade black ABS plastic with smooth finish

Case Composition (barrel): Cyclocac-GSE grade black ABS plastic with medium diamond knurl

Construction: Weatherproof seals at all connecting points

Battery Contacts: Plated coil spring

Excitation Filter: All-dielectric coating, extremely durable when exposed to humidity, heat, thermal shock and abrasion, meets or exceeds MIL-C-675A and MIL-M-13508C specifications

Barrier Filter: Acrylic, selected for its spectral characteristics and durability, 4.2" x 7.7"

BLUEMAXX™ FORENSIC LIGHT

The No. BM300 is **SIRCHIE®**'s standard **BLUEMAXX™** forensic light source. It is supplied complete with both finely tuned barrier and excitation filters. This rugged, self-contained, ABS plastic light source greatly enhances the crime scene investigator's tool chest. In addition to its ability to enhance many types of standard evidence, the No. BM300 also may be used for fluorescent photography. This quality forensic light source uses 3 standard "D" cells.



CATALOG NO. BM300 **BLUEMAXX™ LIGHT** PRICE: \$153.95
CATALOG NO. BM300CC **CARRYING CASE** PRICE: \$32.95

BLUEMAXX™ BM500 RECHARGEABLE FORENSIC LIGHT



No. BM500 Specifications:

- Bulb Type:** 6-volt, 10-watt halogen module with precision parabolic reflector
- Reflector:** Parabolic, calibrated for 5"-8" spot at 10 feet
- Beam Pattern:** Spot
- Maximum Output:** Up to 30,000 candle-power
- Length:** 13.5" (343 mm)
- Weight With Battery:** 1 lb. 10 oz. (737 g)
- Switch:** Ball-bearing operated, beryllium-copper contacts
- Battery:** Nickel cadmium-5 cell, 1/2 "D" battery stick
- Charge Rate:** 220 milliamperes typical
- Charge Time:** 12-14 hours typical
- Case Composition (flange):** Cycolac-T grade black ABS plastic with smooth finish
- Case Composition (barrel):** Cycolac-GSE grade black ABS plastic with medium diamond knurl
- Construction:** Weatherproof seals at all connecting points
- Battery Contacts:** Plated coil spring
- Excitation Filter:** All-dielectric coating, extremely durable when exposed to humidity, heat, thermal shock and abrasion, meets or exceeds MIL-C-675A and MIL-M-13508C specifications
- Barrier Filter:** Acrylic, selected for its spectral characteristics and durability, 4.2" x 7.7"
- CHARGER**
- Construction:** Black ABS "sleeve" type
- Power source:** Input-120 VAC, 60 Hz.
- Charging Indicator:** Red LED
- Output:** 12 VDC, 300 ma.

BLUEMAXX™ RECHARGEABLE FORENSIC LIGHT

This powerful, rechargeable forensic light source features a halogen lamp and a high-capacity battery. It is a super-effective, fully self-contained system, requiring no additional light source or filter. The No. BM500 is supplied complete with matched barrier and excitation filters. This is a one-hand, easy-to-use unit, making it ideal for both fluorescent photography and investigation. A 110-volt or 220-volt charging unit is included, depending on which is specified. A full charge delivers a running time of approximately 1 1/2 hours.

No. BM500 consists of:

- 1-No. BM501 Lamp Module
- 1-No. PL20P Rechargeable Pro-Light™ Flashlight
- 1-No. BMS102 Barrier Filter for Pro-Light™
- 1-No. BMF102 Excitation Filter for Pro-Light™
- 1-No. BM502 Charger Housing
- 1-No. BM503 Charger/Transformer, 110 Volt
- 1-No. BM505 NiCad Battery Stick, 6.0 Volt



The No. BM500 is pictured with an optional carrying case.

CATALOG NO.	DESCRIPTION	PRICE
BM500	BLUEMAXX™ RECHARGEABLE (110VAC)	\$197.95
BM500220	BLUEMAXX™ RECHARGEABLE (220VAC)	\$197.95
BM500CC	CARRYING CASE	\$37.50

BLUEMAXX™ SYSTEM 600 FORENSIC LIGHT

BLUEMAXX™ SYSTEM 600

The **SIRCHIE®** No. BM600 is a high-powered, tripod-mountable, portable forensic blue light source which utilizes an AC power supply. The No. BM600 is especially useful for extended crime scene searches and photography because it does not require any batteries. Crime scene photography is enhanced thanks to the No. BM600's high-light-output levels. An intensity control allows the user to customize the light level for individual needs. The No. BM600 is supplied with a standard 120-volt or 220-volt power supply unit, depending on the unit chosen. The No. BM600 kit is supplied with the No. BM600 light source packaged in a rugged copolymer carrying case

No. BM600 Specifications:

LIGHT HEAD

- Length:** 6.5"
- Major Diameter:** 2.25"
- Minor Diameter:** 1.70"
- Body:** ABS plastic with aluminum head
- Weight:** 9.4 ounces
- Lamp Type:** 20-watt quartz halogen, 12 VDC

INTENSITY ENHANCEMENT

- Lamp Driver:** Power mosfet
- Duty Cycle:** 22-100% typical
- Range:** 4.5 to 20-watts typical
- Parasitic Current:** Below 2 milliamperes

POWER SUPPLY

- Dimensions:** 2.35" x 3.0" x 8.25"
- Weight:** 5 lbs.
- Continuous Duty Amps:** 4.5
- Voltage Regulation:** Solid-state integrated
- Input/Output:** 120 VAC (60 Hz) input, 12 VDC output
- Construction:** Heat sinks with vented cabinet

No. BM600 consists of:

- 1-No. BM6001 AC Extension Cord, 12 ft.
- 1-No. BM6002 Cigarette Lighter Adapter Cord, 10 ft.
- 1-No. BM6003 Light Head, ABS Body with Aluminum Head
- 1-No. BM6004 Power Supply, 120 VAC to 12 VDC, 4.5 amp
- 1-No. BMS300 Barrier Filter Goggles
- 1-No. BM600CC Copolymer Carrying Case with Custom Inserts, Dimensions: 17 1/2" x 10 1/4" x 8 7/8"



The No. BM600 light head is pictured here.



The No. BM600 power source is pictured here.



CATALOG NO. BM600 **BLUEMAXX™ 600 (110 VAC)** **PRICE: \$236.50**
 CATALOG NO. BM600220 **BLUEMAXX™ 600 (220VAC)** **PRICE: \$259.50**

SUPER BLUEMAXX™ ONE MILLION CANDLEPOWER

The **SIRCHIE®** SUPER **BLUEMAXX™** kit is the right forensic tool for extended crime scene searches for physiological fluids such as urine, semen and saliva, certain drugs such as crack cocaine, or materials treated with fluorescent powders or dyes. The filtered output of a highly optimized one-million-candlepower hand-held spotlight provides excitation illumination sufficient to cause trace amounts of materials to glow. The unit is supplied with both an AC-power supply for continuous operation, and a DC-power pack capable of three hours of continuous use. It features a five-inch-diameter, mil spec, all-dielectric excitation filter and 1,000,000 candlepower.



The No. BM800 is pictured with the No. BMS800 barrier filter.



*The SUPER **BLUEMAXX™** is pictured in its case with its components.*



*These prints were photographed after they were enhanced with **SIRCHIE®**'s **REDESCENT™** fluorescent powder.*

No. BMK860 consists of:

- 1-No. BM800 SUPER **BLUEMAXX™** (One Million Candlepower)
- 1-No. BMF800 5" Diameter Excitation Filter
- 1-No. BMS800 Barrier Filter
- 1-No. BM808 Lens Guard
- 1-No. BM810 120VAC/12VDC Converter, 10 amp.
- 1-No. BM817 Rechargeable Battery Pack, 17 Amp-Hour
- 1-No. BM804 Retractable Extension Cord, 10 ft.
- 1-No. BM800CC Carrying Case, Leatherette Vinyl Covered
Dimensions: 24" x 17" x 7 1/2"
Weight: 38 lbs.

CATALOG NO. BMK860 SUPER BLUEMAXX™ KIT PRICE: \$595.50

BLUEMAXX™ FORENSIC PHOTOGRAPHY

Due to the weakness of luminescence, forensic photography often involves extended time exposures and special illumination techniques. As a result, all pictures should be photographed with the camera mounted on a tripod. The **BLUEMAXX™** light source also should be mounted on a tripod, whenever possible, to obtain uniform and even lighting. The No. BMP950 photographic illumination kit described below is supplied with the equipment for properly illuminating a crime scene for photographic purposes.

BLUEMAXX™ PHOTOGRAPHIC ILLUMINATION KIT

This kit is supplied with the necessary components to properly illuminate forensic evidence at the crime scene or the laboratory for photographic purposes. The kit includes a **BLUEMAXX™** light source, a heavy-duty tripod and accessories in a vinyl-leatherette carrying case. A camera and camera tripod are not furnished as they are assumed to be already included in the user agency's inventory.

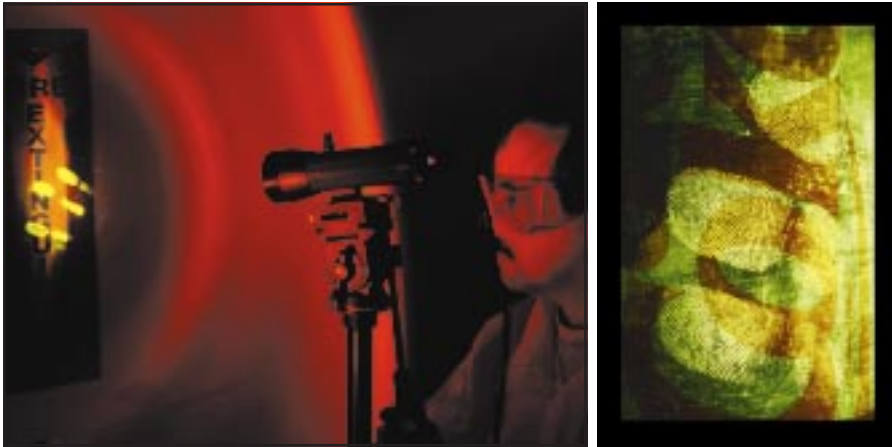

The developed latent prints pictured left are illuminated with the No. BM600 for photographing. The prints pictured right were photographed after they were developed with **SIRCHIE**'s GREENescent™ fluorescent powder.



The No. BM6003 light head is pictured on the tripod mount included in the **BLUEMAXX™** photographic illumination kit.

No. BMP950 consists of:

- 1-No. BM600 **BLUEMAXX™** 600, 110 VAC
- 1-No. BM6004 Power Supply, 120VAC to 12VDC
- 1-No. BM6001 AC Extension Cord, 12 ft.
- 1-No. BM6002 Cigarette Lighter Adaptor Cord, 10 ft.
- 1-No. BMS300 Barrier Filter Goggles
- 1-No. BM6009 Heavy-Duty Tripod for **BLUEMAXX™**
- 1-No. BMCF100 Camera Lens Barrier Filter, (See page 129 for size requirements, please specify when ordering)
- 1-No. BMP950CC Carrying Case, Vinyl Leatherette
Dimensions: 26 1/2" x 13 1/2" x 5"
Weight: 18.5 lbs.



CATALOG NO. BMP950 PHOTOGRAPHIC ILLUMINATION KIT, 110VAC PRICE: \$435.95
CATALOG NO. BMP950220 PHOTOGRAPHIC ILLUMINATION KIT, 220VAC PRICE: \$470.50

Fig. 1



Latent prints developed with No. LL601 Magnetic REDCHARGE™

Fig. 2

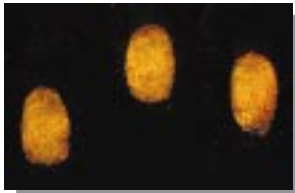

Latent prints developed with No. LL602 Magnetic ORANGECHARGE™

Fig. 3

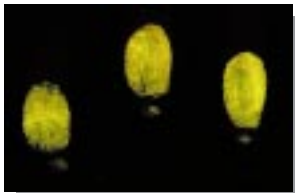

Latent prints developed with No. LL603 Magnetic GREENCHARGE™

Fig. 4



Latent prints developed with No. LL605 Magnetic YELLOWCHARGE™

Fig. 5

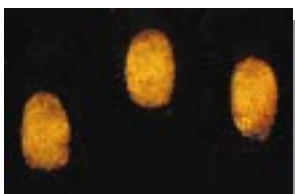

Latent prints developed with No. LL701 REDeSCENT™

Fig. 6

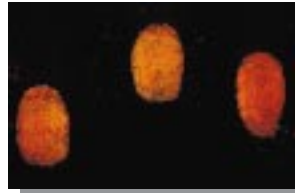

Latent prints developed with No. LL702 PINKeSCENT™

Fig. 7

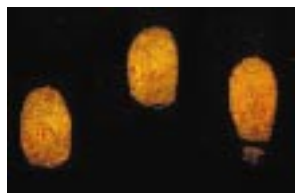

Latent prints developed with No. LL704 SILVER/REDeSCENT™

Fig. 8



Latent prints developed with No. LL703 GREENeSCENT™

Fig. 9



Latent prints developed with No. LL705 YELLOWeSCENT™

Pictured below is a series of photographs of latent prints developed with various **SIRCHIE®** fluorescent powders exposed to a **BLUEMAXX™** light source. The pictures were photographed with a standard 35mm camera and Kodak Ektachrome Elite 150 color slide film. Exposure times varied as noted. The maximum level of brilliance for optimum photographic fingerprint ridge detail may be obtained by varying the exposure time. This type of photographic enhancement is not possible with powder-developed fingerprints that have not been externally excited by a forensic light source.

EXPOSURE GUIDE (USING KODAK ELITE 150/100/21° SLIDE FILM)

Figure	Time	Aperture
1-LL601	4 seconds	f8
2-LL602	15 seconds	f16
3-LL603	4 seconds	f5.6
4-LL605	8 seconds	f4
5-LL701	15 seconds	f5.6
6-LL702	30 seconds	f11
7-LL703	30 seconds	f5.6
8-LL704	15 seconds	f5.6
9-LL705	8 seconds	f4
10-urine	1 second	f5.6
11-saliva	1 second	f5.6
12-semen	1 second	f5.6

Fig. 10

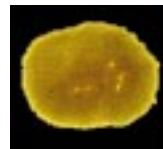

urine

Fig. 11



saliva

Fig. 12



semen

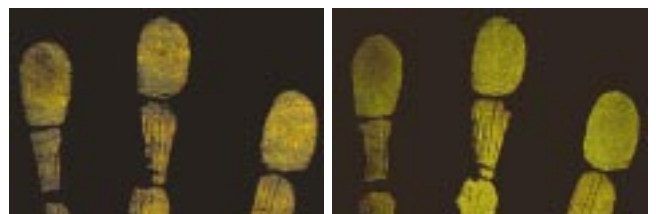

The prints pictured left were enhanced with No. LVS600 ardrex, after fuming fluorescent dye spray—30 seconds at f8. The prints pictured right were enhanced with No. LVS500 basic yellow, after fuming fluorescent dye spray—15 seconds at f5.6

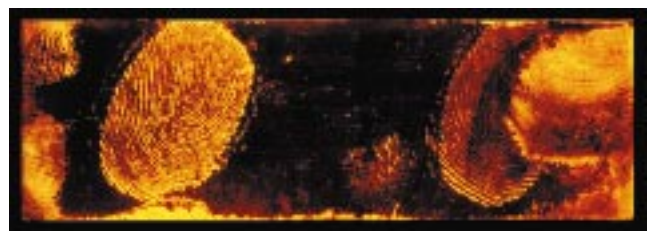

These prints were enhanced with No. LV505 rhodamine 6G after fuming with cyanoacrylate—15 seconds at f11.

BLUEMAXX™ CRIME SCENE SEARCH KITS

BLUEMAXX™ PATROL KIT

Officers may locate, develop, enhance and lift latent fingerprint evidence and locate physiological fluids such as semen (for collection and laboratory analysis) with this kit. The kit is supplied with a choice of **BLUEMAXX™** illumination systems as well as **REDESCENT™** and **GREENESCENT™** fluorescent fingerprint powders. A complete set of instructions also is included.

Kits consist of:

- 1- No. BM300 BLUEMAXX™ Standard Light Source w/ Excitation and Barrier Filter (BMK700 only)
- 1- No. BM500 BLUEMAXX™ Rechargeable Light Source, 110VAC with Excitation and Barrier Filter (BMK705 only)
- 1- No. BM500220 BLUEMAXX™ Rechargeable Light Source, 220VAC with Excitation and Barrier Filter (BMK705220 only)
- 1- No. LL701 REDDESCENT™ Fluorescent Latent Powder, 2 oz.
- 1- No. LL703 GREENESCENT™ Fluorescent Latent Powder, 2 oz.

- 2- No. 123LB Black Marabou Feather Dusters
- 1- No. 144L2 Transparent Lifting Tape, 2" x 360"
- 1- No. 144L4 Transparent Lifting Tape, 4" x 360"
- 10- No. FC34311 Reversible Backing Cards
- 1- No. BMK7001 Copolymer Carrying Case, Dimensions: 17 1/2" x 10 1/4" x 8 1/2"



CATALOG NO. BMK700 KIT WITH BM300 "D" CELL LIGHT PRICE: \$196.95
CATALOG NO. BMK705 KIT WITH RECHARGEABLE BM500, 110VAC PRICE: \$240.95
CATALOG NO. BMK705220 KIT WITH RECHARGEABLE BM500, 220VAC PRICE: \$240.95

BLUEMAXX™ LATENT SPECIALIST KIT

Crime scene search officers can locate, develop, enhance and lift latent fingerprint evidence utilizing a variety of fluorescent powders, both regular and magnetic, with the products supplied in this kit. Fiberglas® and feather applicators and a magnetic wand are included. Physiological fluids such as semen, saliva and urine may be located using the **BLUEMAXX™** for subsequent collection and laboratory analysis. This kit is supplied with a choice of **BLUEMAXX™** illumination systems. Instructions are included.

Kits consist of:

- 1- No. BM300 BLUEMAXX™ Standard Light Source with Excitation and Barrier Filter (BMK750 only)
- 1- No. BM500 BLUEMAXX™ Rechargeable Light Source, 110VAC with Excitation and Barrier Filter (BMK755 only)
- 1- No. BM500 BLUEMAXX™ Rechargeable Light Source, 220VAC with Excitation and Barrier Filter (BMK755220 only)
- 1- No. LL701 REDDESCENT™ Fluorescent Latent Powder, 2 oz.
- 1- No. LL703 GREENESCENT™ Fluorescent Latent Powder, 2 oz.
- 1- No. LL704 SILVER/REDESCENT™ Fluorescent Latent Powder, 2 oz.
- 1- No. LL705 YELLOWESCENT™ Fluorescent Latent Powder, 2 oz.
- 1- No. LL601 REDCHARGE™ Fluorescent Magnetic Powder, 1 oz.
- 1- No. LL603 GREENCHARGE™ Fluorescent Magnetic Powder, 1 oz.
- 2- No. 122L Fiberglas® Latent Print Brushes
- 1- No. 123LB Black Marabou Feather Duster
- 1- No. 123LW White Marabou Feather Duster
- 1- No. 125MD MegaWand™ Magnetic Applicator
- 1- No. 144L2 Transparent Lifting Tape, 2" x 360"
- 1- No. 144L4 Transparent Lifting Tape, 4" x 360"
- 20- No. FC34311 Reversible Backing Cards
- 1- No. BMK7501 Copolymer Carrying Case, Dimensions: 19" x 11 1/2" x 10 1/2"



CATALOG NO. BMK750 KIT WITH BM300 "D" CELL LIGHT PRICE: \$284.95
CATALOG NO. BMK755 KIT WITH RECHARGEABLE BM500, 110VAC PRICE: \$328.95
CATALOG NO. BMK755220 KIT WITH RECHARGEABLE BM500, 220VAC PRICE: \$328.95

BLUEMAXX™ MASTER FUMING AND EVIDENCE LOCATING KIT

This is **SIRCHIE**®'s top-of-the-line **BLUEMAXX**™ kit, and it offers the investigator the capability of handling a wide variety of crime scene circumstances. This kit provides the tools for locating physiological fluids (for subsequent collection), locating and developing fingerprints, enhancing the prints with forensic dyes and powders, and for lifting and processing the latent prints.

The kit includes the No. BM500 rechargeable portable forensic light along with an expanded inventory of fingerprint developing tools and agents.

A practical assortment of both regular and magnetic fingerprint powders and a generous selection of dusting tools for both methods are included.

The kit also features a No. SCW100 Cyanowand™ kit for the added versatility of on-the-spot glue-fuming at the crime scene. Cyanoacrylate-developed prints may be enhanced with fluorescent powder and illuminated with the **BLUEMAXX**™ forensic light for photographing, if desired.

To aid in the final step, the kit includes an ample variety of fingerprint lifting supplies.



Kits consist of:

- 2-No. 123LB Black Marabou Feather Dusters
- 1-No. 123LW White Marabou Feather Dusters
- 1-No. 125GM GigaMag™ Magnetic Wand
- 1-No. 125MD **SEARCH**® MegaWand™
- 1-No. 131LT Hinge Lifter, Transparent, 2" x 4", 12 each
- 1-No. 131LW Hinge Lifter, White, 2" x 4", 12 each
- 1-No. 144L2 Fingerprint Lifting Tape, Transparent, 2" x 360"
- 1-No. 144L4 Fingerprint Lifting Tape, Transparent, 4" x 360"
- 1-No. 317M Magnifier, 3" dia.
- 1-No. BM500 **BLUEMAXX**™ Rechargeable Forensic Light (MFE1000 Only)
- 1-No. BM500220 **BLUEMAXX**™ Rechargeable Forensic Light, 220V AC (MFE1000220 Only)

- 1-No. BMS300 Barrier Filter Goggles
- 1-No. FC343 Reversible Backing Card, 100 each
- 1-No. KCP110 Scissors, 5"
- 1-No. KCP115 Penlight, 2 AA, 1.5 Volt
- 1-No. KCP116 Pocket Notebook with Calendar
- 1-No. KCP220 Spray Head, White, Adjustable
- 1-No. LL601 REDCHARGE™ Fluorescent Magnetic Powder, 1 oz.
- 1-No. LL603 GREENCHARGE™ Fluorescent Magnetic Powder, 1 oz.
- 1-No. LL605 YELLOWCHARGE™ Fluorescent Magnetic Powder, 1 oz.
- 1-No. LL701 REDESCENT™ Fluorescent Latent Print Powder, 2 oz.
- 1-No. LL705 YELLOWESCENT™ Fluorescent Latent Print Powder, 2 oz.
- 1-No. LVS500 Basic Yellow, After Fuming Fluorescent Dye Spray, 500 ml
- 1-No. SCW100 CYANOWAND™ Fingerprint Kit
- 2-No. SCW200 CYANOWAND™ Cartridge Packages, 10 per pkg.
- 2-No. SCW300 Mega-Cartridge Packages, 10 per pkg.
- 3-No. SF00771 Latex Disposable Glove Pairs
- 1-No. MFE1001 Professional Carrying Case, Vinyl-Covered With Steel Hardware
Dimensions: 24 1/4" x 16 3/4" x 8 3/4"
Weight: 19.2 lbs.

CATALOG NO. MFE1000 MASTER KIT, RECHARGEABLE 110VAC PRICE: \$496.50
CATALOG NO. MFE1000220 MASTER KIT, RECHARGEABLE 220VAC PRICE: \$496.50

CONVERTING FLASHLIGHTS TO A FORENSIC LIGHT ...

For departments that wish to use the halogen or krypton flashlights currently in their possession, **SIRCHIE®** offers **BLUEMAXX™** accessories for field or dedicated conversion. **BLUEMAXX™** excitation and barrier filters are the only accessories required to transform the existing flashlight into a **BLUEMAXX™** forensic light source. BOTH an excitation and a barrier filter are needed.

BLUEMAXX™ EXCITATION FILTER

Excitation filters feature superior spectral stability and physical durability characteristics. No degradation of performance is apparent with age—unlike commonly used organic dye or gelatin filter systems. Filter coatings are hard, all-dielectric coatings, extremely durable when exposed to humidity, heat, thermal shock, abrasion and handling. They are manufactured to meet the standards of MIL-C-675A and MIL-M-13058C. Dimensions: 2" dia. x 0.04" thick. Passband is from 390 nm to 520 nm.



CATALOG NO.	DESCRIPTION	PRICE
BMF100	EXCITATION FILTER FOR MAG-LITE® FLASHLIGHTS	\$65.95
BMF101	EXCITATION FILTER FOR STREAMLIGHT® FLASHLIGHTS	\$65.95
BMF102	EXCITATION FILTER FOR PRO-LIGHT® FLASHLIGHTS	\$65.95

BLUEMAXX™ BARRIER FILTER (VIEWING SHIELD)

The barrier filter is made of a transparent acrylic material selected for its spectral characteristics and durability. It is available in a 4.2" x 7.7" standard size and a larger, 10.5" x 6.5" size. Filter edge at 530 nm.

CATALOG NO.	DESCRIPTION	PRICE
BMS100	BARRIER FILTER/MAG-LITE®	\$32.95
BMS101	BARRIER FILTER/STREAMLIGHT®	\$32.95
BMS102	BARRIER FILTER/PRO-LIGHT™	\$32.95
BMS200	LARGE BARRIER FILTER/MAG-LITE®	\$43.95
BMS201	LARGE BARRIER FILTER/STREAMLIGHT®	\$43.95
BMS202	LARGE BARRIER FILTER/PRO-LIGHT™	\$43.95



BLUEMAXX™ BARRIER FILTER GLASSES & GOGGLES

Polycarbonate barrier filter glasses and goggles offer convenient viewing for crime scene searches and photography when using the **BLUEMAXX™** for illumination. Both goggles and glasses are manufactured to meet or exceed ANSI-Z87.1 safety standards. Goggles will fit over corrective eyewear.

CATALOG NO.	DESCRIPTION	PRICE
BMS300	BARRIER FILTER GOGGLES	\$21.95
BMS400	BARRIER FILTER GLASSES W/SIDE SHIELDS	\$29.75



No. BMS300 with case

No. BMS400

CAMERA FILTER ASSEMBLY

Filter threads are measured in millimeters, so obtain a metric ruler. Place the ruler across the diameter (widest part) of the camera lens as illustrated, so that the "0" point is at the inner edge of the lens' filter threads. Read the distance to the opposite side of the lens. Choose the size closest to this measurement from the list of standard filter sizes below.

Standard Filter Sizes

30.5mm	39mm	46mm	52mm	62mm	77mm	95mm
34mm	40.5mm	48mm	55mm	67mm	82mm	
37mm	43mm	49mm	58mm	72mm	86mm	

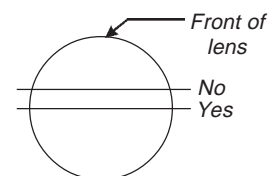

CATALOG NO. BMCF100	CAMERA FILTER (SPECIFY SIZE)	PRICE: \$52.95
----------------------------------	---	-----------------------

SECTION IV TABLE OF CONTENTS

Optical Enhancement and Fingerprint Classification

JC100P Fingerprint Magnifier	131
Classification Discs for JC100P	131
M1 Fingerprint Magnifier	132
M2 Fingerprint Magnifier	132
Classification Discs for M1 and M2	132
JC200 Fingerprint Magnifier	133
Classification Discs for JC200	133
JC300 Wide-Field Magnifier	134
Classification Discs for JC300	134
JC400 Super-Wide Field Magnifier	135
Classification Discs for JC400	135
Illuminated Fingerprint Comparator	136
Professional Folding Magnifier	137
Illuminated Hand-held Magnifiers	137
Gooseneck Magnifier	137
Folding Magnifier	137
Retractable Pocket Magnifier	137
Rectangular Illuminated Magnifier	137
Attached Case Magnifier	137
Fingerprint Comparator	138
Optical Comparators	138-142

MAGNIFY YOUR VISION

If your world revolves around eight-by-eight inch cards, you know that print classification involves hours of peering through optics. A fingerprint technician quickly learns the worth of a good optical system and the costs of a poor one. **SIRCHIE**® offers a wide range of optical systems, from simple readers to super-wide-field magnifiers. Each is designed to provide:

- a wide field-of-view, so that you can see the entire target at once;
- low distortion, so that things look like they're supposed to;
- high-eye-relief, so that your eye does not have to remain in physical contact with the magnifier to avoid the feeling that you are looking through a tunnel;
- and a flat field, so that targets appear in focus across the entire field of view.

If comparison is more your style, you'll find our forensic optical comparators offer unequalled high resolution, high contrast and bright images without glare, hot spots or vignetting.

SIRCHIE®'s new video-optical comparator is capable of direct output to video monitors, recorders and computers.

Optical Enhancement ... **SIRCHIE**®

THE JC100P PROFESSIONAL FINGERPRINT MAGNIFIER

The No. JC100P professional fingerprint magnifier and its compatible coding discs are a rugged, high-quality magnifying system which provides optimum performance for the examination and classification of fingerprint evidence.

The No. JC100P optics assembly consists of precision-machined, nickel-plated brass that houses the 4.5X magnification two-element optical glass lens system. Precision-focusing is accomplished by raising or lowering the optics assembly on its threaded focusing mount. The optional No. JC101LR locking ring ensures that the setting is maintained.

The No. JC100P is sturdy and rugged, cast in solid stainless steel—ensuring years of wobble-free performance. The No. JC100P, and the four classification discs designed specifically for use with the JC100P offer the user a superior examination tool with no compromise in quality and performance.



The No. JC100P professional fingerprint magnifier is pictured with the optional No. JC101M classification disc.

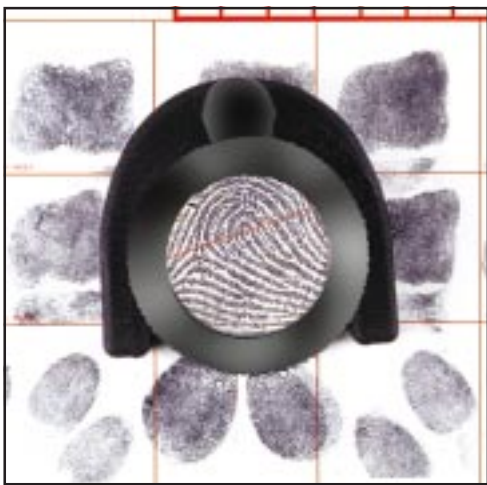

This is an actual view of a fingerprint through the No. JC100P professional fingerprint magnifier.

Leading Particulars

- Stainless steel cast base
- Three-lens optics (doublet and plano-convex 1.4" dia., 4.5X)
- 1 3/8" diameter aperture
- 7/8" focus adjustment
- Positive lock disc mount
- Black wrinkle-textured paint
- Weight: 11.8 oz.



CATALOG NO. JC100P 4.5X MAGNIFIER W/ BLACK WRINKLE FINISH PRICE: \$87.95
CATALOG NO. JC101LR BLACK ANODIZED KNURLED LOCKING RING PRICE: \$9.50

JC100P COMPATIBLE CLASSIFICATION DISCS

These discs are designed for use exclusively with the No. JC100P professional fingerprint magnifier. The discs utilize optical-quality glass with quality precision silk screened lines. The classification disc housing is machined from tempered aluminum and finished with an optical black anodize.

CATALOG NO.	DESCRIPTION	PRICE
JC101H	HENRY DISC	\$24.25
JC101B	BATTLETT DISC	\$52.25
JC101HB	HENRY/BATTLETT DISC	\$46.75
JC101M	MIRACODE PALM DISC	\$47.25

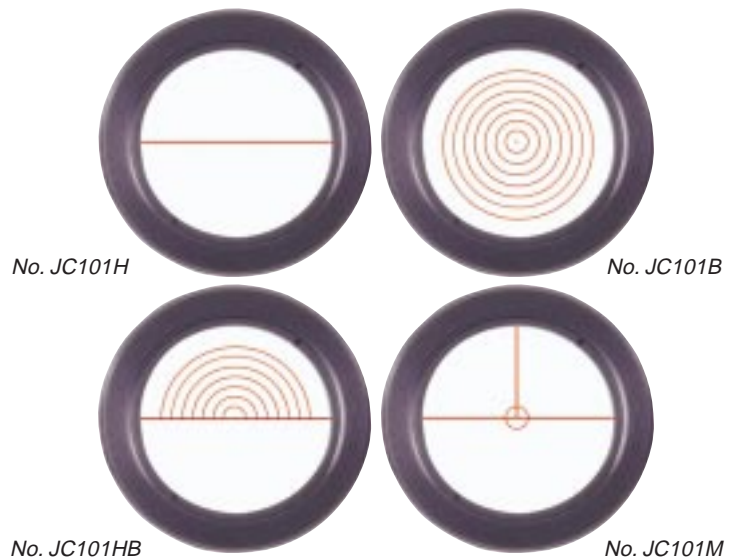

OPTICAL ENHANCEMENT AND FINGERPRINT CLASSIFICATION



M1 PROFESSIONAL FINGERPRINT MAGNIFIER

The M1 professional magnifier is known for its outstanding performance and rugged construction. It is constructed of precision-machined aluminum, finished with optical black anodizing. The two-element lens system provides 5X magnification with 1 1/4" field of view. The M1 delivers superb image clarity and sharpness and features coarse and fine focusing adjustments as well as a ring lock to set focus for extended use. The base of the M1 is designed for use with the PF series of classification discs, allowing for easy installation and removal of discs. Spring-loaded ball bearings are incorporated in the base to allow for full 360-degree rotation of classification discs.

Leading Particulars

- All-metal black anodized aluminum construction
- Two-lens optics (doublet and plano-convex, 1.4" dia, 5X)
- 1 3/8" aperture
- Knurled black anodized locking ring
- Positive lock disc mount
- Coarse and fine focus adjustments
- Weight: 7.5 oz.

The M1 professional magnifier, No. PFP100, is pictured with the optional classification disc, No. PFM13.

CATALOG NO. PFP100 M1 MAGNIFIER PRICE: \$70.95

M2 PROFESSIONAL FINGERPRINT MAGNIFIER

The M2 is an excellent fingerprint magnifier constructed from precision-machined extruded aluminum with an optical black anodized finish. The M2 provides 4.5X magnification using a two-element glass optics system which provides great clarity with a minimum of distortion. The magnifier's height adjustment knob allows for easy positioning of the optics. The base is designed for use with the PF series of classification discs, and allows for easy installation and removal of discs. Spring-loaded ball bearings are incorporated in the base for full 360-degree rotation of the classification discs.

Leading Particulars:

- All-metal extruded aluminum construction
- Two element optics (plano-convex, 1.5" dia., 4.5X)
- Optical black anodized finish throughout
- Fast, precision focusing
- Positive lock disc mount
- Weight: 7.9 oz.



CATALOG NO. PFP200 M2 MAGNIFIER PRICE: \$54.50

CLASSIFICATION DISCS FOR THE M1 AND M2 MAGNIFIERS

The PF series of classification discs is designed for use with the M1 and M2 magnifiers. Optical-quality glass with precision silk screened lines is set in tempered aluminum and optical black anodize finish.



No. PFH10



No. PFB11



No. PFHB12



No. PFM13

CATALOG NO.	DESCRIPTION	PRICE
PFH10	HENRY DISC	\$23.25
PFB11	BATTLE DISC	\$43.50
PFHB12	HENRY/BATTLE DISC	\$45.25
PFM13	MIRACODE PALM DISC ...	\$46.25

JC200 FINGERPRINT MAGNIFIER

This professional fingerprint magnifier features a smooth rack-and-pinion focusing mechanism. A two-element 4.5X magnification optical system ensures sharp, clear images. The frame is a quality, one-piece unit cast from zinc for ideal weight and stability. The lens barrel and focusing control are stainless steel. See below for classification disc choices.

Specifications

Net Weight	14.1 oz. (399 g)
Dimensions	2 5/8" x 2 5/8" x 3 1/4" (6.7 cm x 6.7 cm x 8.3 cm)



The No. JC200 fingerprint magnifier is pictured in use.



The No. JC200 fingerprint magnifier is pictured with the optional No. JC201M classification disc.

Leading Particulars

- Focusing Knob: Stainless steel
- Lens Housing: Stainless steel
- Magnifier Base: Cast zinc, black wrinkle epoxy paint
- Opening at Base: 1 15/16"

CATALOG NO. JC200 FINGERPRINT MAGNIFIER PRICE: \$146.50

CLASSIFICATION DISCS FOR JC200 FINGERPRINT MAGNIFIER

These quality classification discs are intended exclusively for use with the **SIRCHIE®** No. JC200 fingerprint magnifier. Optical-quality glass with precision silk screened lines is securely mounted in a tempered aluminum frame. Discs weigh 1.2 ounces and measure 1/4" x 2 1/4" diameter.



No. JC201H



No. JC201B



No. JC201HB



No. JC201M

Leading Particulars

- Materials: Tempered aluminum
- Finish: Optical black anodize

CATALOG NO.	DESCRIPTION	PRICE
JC201B	BATTLEY DISC	\$52.25
JC201H	HENRY DISC	\$24.25
JC201HB	HENRY/BATTLEY DISC	\$46.75
JC201M	MIRACODE PALM DISC	\$47.25

JC300 WIDE-FIELD PROFESSIONAL FINGERPRINT MAGNIFIER

The **SIRCHIE**® No. JC300 allows the user to study a much larger field of view than standard fingerprint magnifiers. A thumb-screw allows fast and simple focus adjustments. Images appear sharp, clear and focused over the entire viewing area. This 3.2X magnification wide-field magnifier is constructed with a sturdy aluminum frame. See below for optional classification discs. The magnifier weighs 11.5 ounces (326 g) and measures 4 1/2" x 4 1/4" x 3".



The JC300 professional fingerprint magnifier is pictured with the optional No. JC301H classification disc.

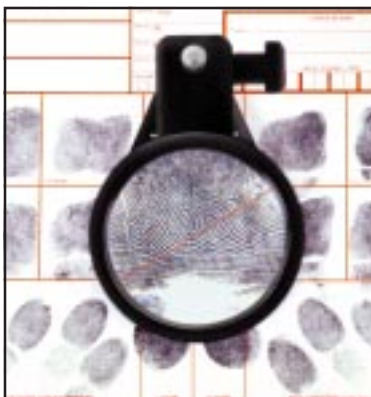

Leading Particulars

- Disc Holder: Threaded to allow for secure attachment
- Materials: Black anodized aluminum alloy
- Positioning of Optics Knob: Allows for ease of adjustment
- Opening at Base: 2 7/16"

CATALOG NO. JC300 ... WIDE-FIELD PROFESSIONAL FINGERPRINT MAGNIFIER ... PRICE: \$119.95



The Henry classification disc, No. JC301H, is pictured here.

CLASSIFICATION DISCS FOR JC300 FINGERPRINT MAGNIFIER

These quality classification discs are designed exclusively for the No. JC300 wide-field magnifier. They utilize optical-quality glass with quality precision silk screened lines.

Specifications	JC301B	JC301H	JC301HB	JC301M
Net Weight	0.9 oz. (26 g)	0.9 oz. (26 g)	0.9 oz. (26 g)	0.9 oz. (26 g)
Dimensions	1/4" x 2 3/4" dia. (0.6 cm x 7 cm dia.)	1/4" x 2 3/4" dia. (0.6 cm x 7 cm dia.)	1/4" x 2 3/4" dia. (0.6 cm x 7 cm dia.)	1/4" x 2 3/4" dia. (0.6 cm x 7 cm dia.)



No. JC301H



No. JC301B



No. JC301HB



No. JC301M

Leading Particulars

- Finish: Black anodized
- Glass Disc: Quality precision silk screened lines
- Material: Tempered aluminum

CATALOG NO.	DESCRIPTION	PRICE
JC301B	BATTLEY DISC	\$56.25
JC301H	HENRY DISC	\$44.50
JC301HB	HENRY/BATTLEY DISC	\$52.95
JC301M	MIRACODE PALM DISC	\$54.50

JC400 SUPER-WIDE-FIELD PROFESSIONAL FINGERPRINT MAGNIFIER

This high-quality fingerprint magnifier features an exceptionally wide field-of-view. This is an ideal fingerprint comparison magnifier due to the quality optics and the super-wide viewing area. Focusing is a quick and simple matter using the convenient thumbscrew locking adjustment. The solid, all-aluminum frame construction of this 3.5X magnification unit ensures stability and longevity. See below for optional classification disc choices.

Specifications

Net Weight
Dimensions

12.5 oz. (354 g)
5 3/4" x 4 1/4" x 3 1/2"
(14.6 cm x 10.8 cm x 8.9 cm)



The JC400 professional fingerprint magnifier is pictured with the optional No. JC401H classification disc.



Leading Particulars

- Disc Holder: Threaded to allow for secure attachment
- Materials: Black anodized aluminum alloy
- Positioning of Optics Knob: Allows for ease of adjustment
- Opening at Base: 2 5/16"

CATALOG NO. JC400 SUPER WIDE-FIELD MAGNIFIER PRICE: \$139.95

CLASSIFICATION DISCS FOR JC400 FINGERPRINT MAGNIFIER

These classification discs are intended exclusively for the **SIRCHIE®** No. JC400 magnifier. They utilize optical-quality glass with quality precision silk screened lines.

Specifications	JC401B	JC401H	JC401HB	JC401M
Net Weight	1.2 oz. (35 g)	1.2 oz. (35 g)	1.2 oz. (35 g)	1.2 oz. (35 g)
Dimensions	1/4" x 3 1/4" dia. (0.6 cm x 8.3 cm dia.)	1/4" x 3 1/4" dia. (0.6 cm x 8.3 cm dia.)	1/4" x 3 1/4" dia. (0.6 cm x 8.3 cm dia.)	1/4" x 3 1/4" dia. (0.6 cm x 8.3 cm dia.)



No. JC401H



No. JC401H



No. JC401B



No. JC401HB



No. JC401M

Leading Particulars

- Finish: Black anodized
- Glass disc: precision silk screened lines
- Material: Tempered aluminum

CATALOG NO.	DESCRIPTION	PRICE
JC401B	BATTLE DISC	\$66.25
JC401H	HENRY DISC	\$54.50
JC401HB	HENRY/BATTLE DISC	\$62.95
JC401M	MIRACODE PALM DISC	\$64.50

OPTICAL ENHANCEMENT AND FINGERPRINT CLASSIFICATION



No. 320M
1.75X
4 1/2" (dia.)

No. 319M
2X
4" (dia.)

No. 318M
2X
3 1/2" (dia.)

No. 317M
2X
3" (dia.)

No. 316M
3X
2 1/2" (dia.)

MAGNIFIERS/FINGERPRINT READERS

These magnifiers feature high-grade, optically ground and polished glass lenses for maximum detail. They are ideally suited for the examination of latent prints and other physical evidence.

CATALOG NO.	DESCRIPTION	PRICE
316M	2 1/2" MAGNIFIER	\$9.50
317M	3" MAGNIFIER	\$13.50
318M	3 1/2" MAGNIFIER	\$15.50
319M	4" MAGNIFIER	\$17.75
320M	4 1/2" MAGNIFIER	\$21.95

THE 365M ILLUMINATED COMPARATOR

Classifying and comparing latent fingerprints is a vital task, yet it can be time consuming and tedious. The No. 365M illuminated comparator was designed to provide the examiner with an exceptional tool for the examination of evidence. The No. 365M has a five-inch diameter glass lens that provides sharp, clear images at 2X magnification and a wide field-of-view, thus minimizing eye strain. The No. 365M incorporates a built-in, 4-watt, cool-white fluorescent light source that provides added illumination.

The lens and light source are mounted to a fully adjustable boom support which allows for easy, precise adjustment. The assembly is mounted on a hardwood, Formica®-covered base that serves as a specimen platform for fingerprint cards, documents or other physical evidence. Dimensions: 13" x 9" x 8.5". Weight: 4.9 lbs



Leading Particulars

- Evidence Base: Formica®-covered base, tacky surface
- Height Adjustment: 1 1/4" to 8 1/2" above platform
- Magnifier: 5" diameter optical glass, 2X magnification
- Swivel Action: 360 degrees

CATALOG NO. 365M PRICE: \$164.50



ILLUMINATED FINGERPRINT MAGNIFIER

This illuminated fingerprint magnifier is a handy tool. It features optically ground and polished lenses useful for classifying fingerprints and for examining evidence. The unit is battery operated by two "D" cells (batteries not included). Weight: 6.9 oz.

CATALOG NO. 314M PRICE: \$43.50



RECTANGULAR ILLUMINATED MAGNIFIER

This professional-size magnifier (4" x 2" lens) is an excellent aid for examining fingerprints and other evidence. An ON/OFF switch is provided for the battery-supplied illumination. The unit is supplied with batteries and a spare bulb. Weight: 4.8 oz.

CATALOG NO. 326M PRICE: \$35.75



PROFESSIONAL FOLDING MAGNIFIER

This high-quality, 5X magnification, fixed-focus magnifier folds up into a compact unit for storage in a vinyl case. The lenses are of fine-quality, optically ground and polished glass. The base is clearly marked with graduation lines on all four sides. It is ideal for the examination of fingerprints.

CATALOG NO. 313M PRICE: \$21.95



GOOSENECK MAGNIFIER, 4" DIAMETER

The gooseneck magnifier features a 4" optically ground and polished lens that is mounted to a flexible neck for versatility in handling. The unit's base is black cast iron. Revolving ferrule and round rims are chromium-plated brass. Weight: 3.5 lbs.

CATALOG NO. 322M PRICE: \$37.95



RETRACTABLE MAGNIFIER

This handy, retractable magnifier gives full 2X magnification over a 2 3/4" x 1 1/2", yet retracts to only 3 1/4"—allowing it to easily fit in a pocket (extended length is six inches). The push-pull lens (pull to open, push to close) is mounted in a body of high-impact plastic that keeps the lens safe and clean when closed. Weight: 1.4 oz.

CATALOG NO. 325M PRICE: \$9.95



ATTACHED CASE MAGNIFIER

This is a conveniently sized, inexpensive, fold-up magnifier with a 1 3/4" diameter lens. It is the perfect size for kits or to carry in a pocket.

CATALOG NO. 379M PRICE: \$4.50

THE FX8B FORENSIC OPTICAL COMPARATOR

**OUTSTANDING PERFORMANCE AND CONVENIENT, COMFORTABLE OPERATION
ALLOWS FOR THOROUGH, EFFICIENT EVIDENCE EXAMINATION**



The examination of physical evidence demands a critical eye. Normally, such examination is a tedious, eye-straining chore since it usually requires hours of peering through a microscope or magnifier at evidence. The No. FX8B forensic optical comparator takes the tedium and eye-strain out of evidence examination and comparison. The No. FX8B puts the work up front, providing a clear, crisp, magnified image without requiring the examiner to peer through a lens. This unit is ideal for close, careful examination and comparison of physical evidence.

THE FX8B FORENSIC OPTICAL COMPARATOR

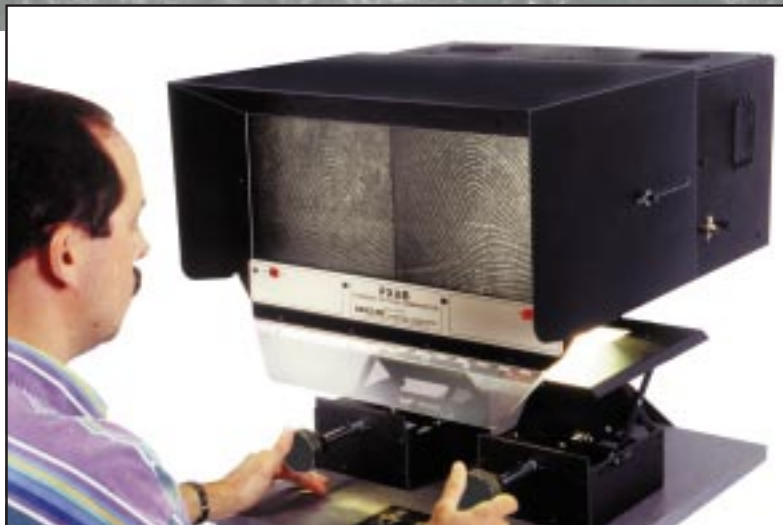

The No. FX8B forensic optical comparator features convenient, accessible projector controls.

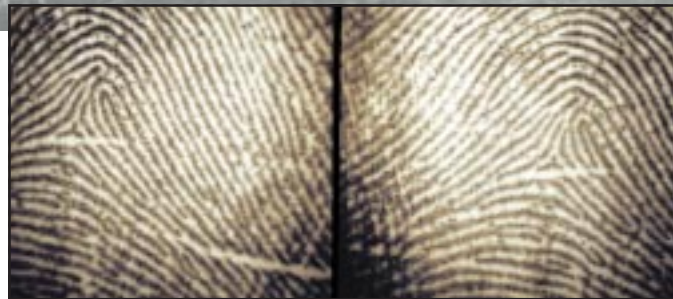

This picture illustrates how two fingerprints may be compared side-by-side under 10X magnification. Note the superior ridge definition and freedom from distortion over the entire screen area.

The No. FX8B is designed exclusively for operator convenience and performance. The No. FX8B features two projectors for a full-screen, side-by-side display of two images—without image overlap. Latent fingerprints may be compared with recorded prints; suspected counterfeit money may be compared with legal tender; and questioned documents and signatures may be compared with genuine articles. Two quartz projection lamps are controlled by individual front-panel switches for dual or single unit usage. Optics carried by the turret automatically provide appropriate surface illumination. Each lamp compartment is monitored by a thermal switch which allows the silent-run fan to continue to operate even after shut off. A matched pair of color-corrected, side-by-side f/3.5 objective lenses provide 6.5X and 10X magnification. Control knobs raise and lower the unit's two surface platforms for image focusing.

Leading Particulars

- Dual screen projections
- No image overlap
- Dual 300-watt quartz projection lamps
- Dual or simultaneous operation
- Adjustable focusing platforms
- Matched f/3.5 objective lenses
- Dual power magnification (6.5X and 10X)
- Sliding turret with pre-focused illumination
- Four-inch internal cooling fan
- Thermal cutoff of fan below 100° F
- Aluminum/steel construction
- Hardwood Formica®-covered base
- Easy access relamping doors
- Viewing screen 6 1/2" x 15"
- Sliding ambient light shield
- Overall Dimensions:
20 1/2" x 18" x 20 1/4"
- Weight: 51.3 lbs.
- 120 VAC 50/60 Hz operation (220V available)



The No. FX8B features smooth, fine-focus focusing platforms.



This is a close-up of the unit's turret-mounted lenses and its dual-quartz light source.



The No. FX8B delivers clear, sharp images.



Easy access makes bulb replacement easy.

CATALOG NO. FX8B FORENSIC OPTICAL COMPARATOR PRICE: \$1,645.00
CATALOG NO. FX8B220 FORENSIC OPTICAL COMPARATOR, 220 VAC PRICE: \$1,690.00

REPLACEMENT PARTS

CATALOG NO. FX8BHSL HEAT ABSORBING LENS PRICE: \$25.50
 CATALOG NO. FX8BSW TOGGLE SWITCH PRICE: \$29.50
 CATALOG NO. FX8BVS VIEWING SCREEN PRICE: \$34.50
 CATALOG NO. SFL1091 PROJECTION LAMP, 300 WATT PRICE: \$29.95

THE FX10 FORENSIC OPTICAL COMPARATOR



The No. FX10 Forensic Optical Comparator is an electronic comparator which promises to play an important role as a stand-alone comparator as well as a tool to extract, enhance and compare evidence on computer.



Above are photographs of actual fingerprint displays from an FX10. The topmost display is a single fingerprint image projected full-screen. The other display is a split-screen projection of two prints shown side-by-side. The magnification of each image may be individually controlled within a range of 3.5 power to 27 power.

VIDEO-BASED OPTICAL COMPARATOR



Leading Particulars:

Color Monitor

- Power Source: 120V, 60Hz, AC
- Video Input Jacks: (3) 1V p-p 75 ohm, BNC connectors
- Audio Input Jacks (3) 500mV rms, RCA connectors
- S-Video Input Jack: S-Video (Y-C) connector
- Video Monitor Output Jack: BNC connector
- Audio Monitor Output Jack: RCA connector
- Video Throughout Jacks: (3) BNC connectors
- Audio Throughout Jacks: (3) RCA connectors
- S-Video Throughout Jacks: S-Video (Y-C) connectors
- Earphone Jack (13" models only): 1/8" mini plug type
- Closed Caption Display

Cameras

- Type: Black and White Interline Transfer CCD, 512 X 492 pixels
- Sensitivity: 0.3 lux
- Resolution: 550 horizontal lines
- TV System: EIA Standard
- Zoom Ratio: Approx. 8X
- Aperture: F7 (wide angle) - F10 (telephoto)
- Image Format: 1/3" 4.8mm x 3.6mm (ø 6mm), 1/2" 6.4 mm x 4.8mm (ø 8mm)
- Working Distance: 127mm - 500mm (distance between object and first lens element)
- Effective Diameter: Front ø 25mm Rear: ø 15mm
- Lens Construction: 7G 10E
- Back Focus: 19.8mm at working distance 235mm
- Flange Back: 12.5mm CS-Mount
- Filter Size: M40.5mm x P0.5
- Dimensions: 149.5mm x ø 46mm

THE FX10 FORENSIC OPTICAL COMPARATOR

about THE VIDEO-BASED OPTICAL COMPARATOR ...

The **SIRCHIE**® FX-10 Forensic Video-Based Comparator utilizes two matched video cameras and a digital video splitter to display objects on a video monitor. Camera images may be presented split side by side on the screen, or they may be presented independently at full screen size. The user may adjust the video display image position, size and balance. Through the video out terminal of either the comparator or the video monitor, the output of the unit (as seen on the video monitor) may be sent to a video recorder or to a computer system equipped with a video capture board for capture and further enhancement.

The cameras feature automatic gain control to ensure optimum images in varied lighting. Zoom magnifications range continuously from ~5X to ~59X power with the monitor supplied. Images remain in sharp focus throughout the zoom range (no refocusing required). Dual 20-watt circular fluorescent lamps offer bright, cool, shadow-free illumination, extremely long lamp life and inexpensive bulb replacement. Adjustable platforms allow for the observation and comparison of three-dimensional evidence by correcting for the height of objects of evidence.



The video output from the No. FX10 may be utilized in conjunction with a variety of electronic equipment, including video printers, VCRs, and with an appropriate video capture card, software with a personal computer.

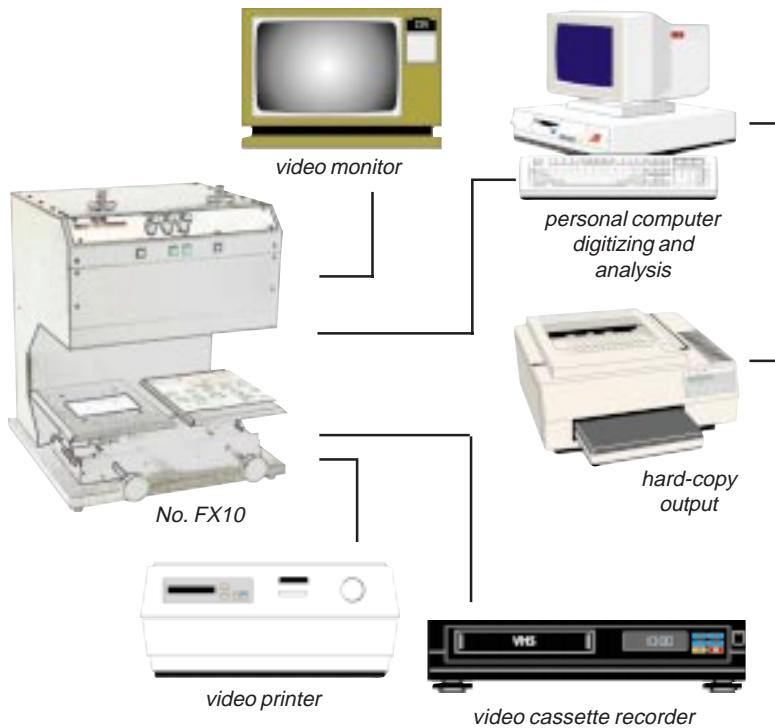

Comparator Controls include:

- Zoom: Adjusts the image magnification for each camera
- Stage height: Adjusts the object to lens separation to accommodate three-dimensional objects of evidence
- Power: On/Off
- Lights: On/Off
- Camera 1: Display Camera 1 image only
- Camera 2: Display Camera 2 image only
- Split: Display both camera images on a split screen
- Horizontal: Adjust the horizontal placement of Camera 1 image
- Vertical: Adjust the Vertical placement of Camera 1 image
- Fade: Adjust the transparency of Camera 1 image
- Balance: Adjust the relative brightness of the two images

SPECIFICATIONS:

Optical

Zoom Ratio: ~8x
 Magnification: ~5X - ~59X
 Aperture: f7 to f10
 Lens Construction: 10 elements in 7 groups
 Filter Size: M40.5 X P0.5

Video Splitter

Digital Memory: 512 X 512 with 256 Gray Levels
 Video Signal: 50 Hz., 525 Line
 Voltage: 120 vac, 50/60 Hz.
 Humidity: 0 to 95% non-condensing

CAT. NO.	DESCRIPTION	PRICE
FX10	FX10 VIDEO-BASED OPTICAL COMPARATOR	\$5,495.00

THE **SEARCH**® FC281 FINGERPRINT COMPARATOR

**PROFESSIONAL QUALITY,
ECONOMICAL,
PORTABLE ...**



This is a close-up of an actual screen display on the No. FC281 fingerprint comparator.



FC281 FINGERPRINT COMPARATOR

The No. FC281 is a professional-quality optical comparator designed for comparing fingerprints, handwriting specimens and other items at an affordable price. This unit is portable (weight 28 lbs., 6 oz.) and features dual optics (f/2.8 projection lenses, providing 6X magnification), rack-and-pinion focus, a dual-image viewing screen (6 1/2" x 9 1/2") and a built-in ambient light shield. It can project images from a variety of sources including photographs, tape lifts, hinge lifters (transparent or opaque), rubber lifters and standard 8" x 8" record cards. A transparent Plexiglas™ hold-plate permits exact location of any object—or any object may be placed over the hold plate. Irregular or curved surfaces also may be viewed by holding them in place over the optic target hole and focusing. An internal exhaust fan keeps the projection lamp cool, ensuring maximum lamp life.



The No. FC281 fingerprint comparator is pictured in use.

Leading Particulars

- All-metal aluminum/steel construction
- Dual f/3.5 optics (no image overlap)
- Independent rack-and-pinion focusing
- 150-watt projection lamp
- Forced air cooling
- Fixed viewing screen hood
- Clear Plexiglas™ hold down plates
- Front surfaced mirrors
- 6X magnification
- Portable
- Dimensions: 15 3/4" L x 12 3/8" W x 20" H
- Weight: 20 lbs.
- 120 VAC 50/60 Hz operation (220-volt operation available)

CATALOG NO. FC281 FINGERPRINT COMPARATOR PRICE: \$645.50
CATALOG NO. CGPCGS REPLACEMENT BULB PRICE: \$32.45

FORENSIC AND IDENTIFICATION PHOTOGRAPHY

Presenting photographic systems and accessories specifically for the demands of the crime scene and the station house.

The distinguishing characteristics of all **SIRCHIE**®'s camera systems are:

- Simplified operation: uniformly excellent results from officers of any skill level;
- Low maintenance: improved designs from an appreciation of the realities of the field;
- High integration: built-in components are not subject to loss or to being misplaced when they're needed.

The crime scene/latent print technician will appreciate the **EV~CAM**™ series of fixed focus 1:1 camera systems with integral flash which offers true, life-size imaging on the most popular film formats. In combination with **SIRCHIE**®'s markers, rules, labels and other mapping aids, these systems help to preserve the evidence and the context of the scene.

For the fixed station, the XZ series of fixed focus, twin lens, mugshot cameras features integral flash and automatic frame advance to speed the processing of suspects.

A wide variety of camera stands and photo-identification signs complement the cameras.

SECTION V TABLE OF CONTENTS

Forensic and Identification Photography

Accessories, Camera	149
Booklets, Identifier Photo	173
Cameras, Evidence	144-146
Cameras, Photo Identification	153-155
Cones, Photo Evidence	172
Filing Systems, Rogues Gallery	166-167
Film, Polaroid	150
Indicators, Photo Evidence	172
Kits, Forensic Photography	148
Kit, Investigator's Mapping	173
Kits, Photo Documentation	174-175
Lens Adapter	151
Numbers, Photo Evidence	172
Rules, Rulers and Rule Tape	149
Scales, Photograph	168, 170-171
Screens, Identification Height	167
Signs, Photo Identification	158-162
Stands, Camera	156-157
Systems, Photo Identification	163-165

EVIDENTIAL FINGERPRINT PHOTOGRAPHY



WHEN AND WHY ... EVIDENTIAL FINGERPRINT PHOTOGRAPHY

1. All successful latent fingerprint examinations conclude with a photograph. All photography of developed fingerprints should be of a high standard—otherwise critical detail may be lost.
2. Some developed fingerprints may fade. This is particularly true if the prints are developed with iodine. That's why the prints should be photographed immediately. Just remember, a comprehensive and fundamental rule for powder-developed prints is "before lifting—photograph."
3. Latent fingerprints processed sequentially (for example, with iodine, ninhydrin, silver nitrate and cyanoacrylate) absolutely must be photographed at each stage of development.
4. Ideally, latent prints should be photographed LIFESIZE or 1:1.
5. Fixed-focus cameras are a must for evidential photography, and **SIRCHIE**® evidence cameras are the preference in the law enforcement community.

SIRCHIE®'s No. EVC1000, EV~CAM™ III is designed for evidential fingerprint photography.



This is a sectional view of the No. EVC1000, EV~CAM™ III evidence camera.

EV~CAM™ III Specifications:

Aperture Range: F3.5-F22

Shutter Type: Rotary solenoid

Flash Voltage: 270 volts typical

Charge Current/Right Pack: 110 ma typical (fast charge) 15 ma typical (trickle charge)

Operating Voltage/Right Pack: 4.8 volts

Operating Voltage/Left Pack: 4.8 volts

Flash Duration: 1/5000 second (full setting)

Recycle Time: 5-7 seconds typical (B&W film)

Battery Charge Input: 12 volts, 500 ma min, (AC or DC)

Film Type: Polaroid pack film, color or black-and-white, 3 1/4" x 4 1/4"

THE EV~CAM™ III EVIDENCE CAMERA

The EV~CAM™ III is designed for 1:1 evidential photography. Prior photographic experience is not necessary to achieve superior results in recording latent fingerprint and other physical evidence with this camera.

The EV~CAM™ III's versatility is unequalled and it offers the most desired features required by a demanding science—flexibility, reliability and simplicity.

Leading Particulars

- Color or black-and-white capability
- Fixed focus
- Variable flash control
- Film speed selection switch
- Instant Polaroid film for instant results
- Electronic shutter
- Rechargeable nickel cadmium batteries
- Audible "beep" low battery indicator

Operation Particulars

- Bright flashing dual solid state lamps indicate flash readiness
- Short "beep" audible signal indicates initial flash readiness
- "Sure-Grip" handles allow easy operation on all surfaces
- Instant processing Polaroid film
- Charged battery typically produces 200 pictures

EV~CAM™ is the "EVIDENCE CAMERA"
only by **SIRCHIE**®



CATALOG NO. EVC1000 COMPLETE AS SPECIFIED W/110VAC CHARGER PRICE: \$874.50
 CATALOG NO. EVC1000220 COMPLETE AS SPECIFIED W/220VAC CHARGER ... PRICE: \$901.50

THE EV~CAM™ III IN OPERATION AND THE RESULTANT PHOTOGRAPHS

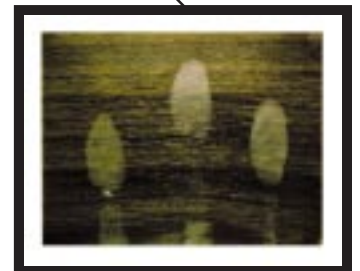
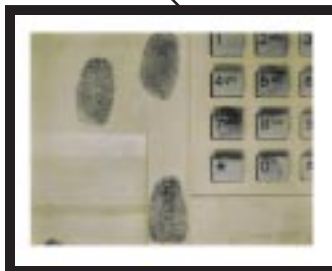
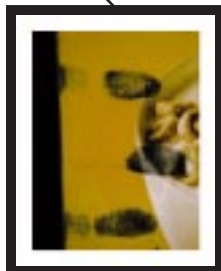

THE EV~CAM™ IV EVIDENCE CAMERA



The EV~CAM™ IV is a versatile, fixed-focus evidence camera, excellent for photographing a variety of physical evidence including fingerprints, signatures, tool marks, palm prints and blood patterns. The EV~CAM™'s large, 4" x 5" format and loading back accommodates standard 4" x 5" cut film holders or Polaroid 4" x 5" land film holders.

EV~CAM™ IV Leading Particulars

- Color or black-and-white capability, 4" x 5" format
- No focusing required—fingerprints, photographs, printed pages and other types of evidence photographed in focus
- Continuously variable flash brightness control allows perfectly exposed shots
- Color/Black-and-white switch allows instant switching between the two types of film
- Polaroid film allows the investigator to view and compare the photograph before leaving the crime scene—eliminating guesswork and uncertainty
- Flash intensity is electronically controlled to prevent exposure variations
- State-of-the-art electronic shutter for precise exposures

Film Accommodation

Uses Polaroid #545 sheet film holder, which will accept Polaroid type 51 (320 ASA/black-and-white), type 52 (400 ASA/black-and-white), type 55 (50 ASA/positive/negative), type 57 (3000 ASA/black-and-white) and Type 59 (80 ASA/color) films. Various standard 4" x 5" cut film holders and associated films will work.

EV~CAM™ IV Specifications:

- Aperture Range:** F3.5-F22
- Shutter Type:** Rotary solenoid
- Flash Voltage:** 270 Volts typical
- Charge Current/Right Pack:** 110 ma typical (fast charge)
15 ma typical (trickle charge)
- Charge Current/Left Pack:** 110 ma typical (fast charge)
15 ma typical (trickle charge)
- Operating Voltage/Right Pack:** 4.8 Volts
- Operating Voltage/Left Pack:** 4.8 Volts
- Flash Duration:** 1/5000 second (full light setting)
- Recycle Time:** 5-7 seconds typical (B&W film)
- Battery Charger Input:** 12 Volts, 500 ma (AC or DC)
- Film Type and Holders:** Polaroid #545 film holder (4" x 5"). Will also accept standard 4" x 5" cut film holders and their associated films.

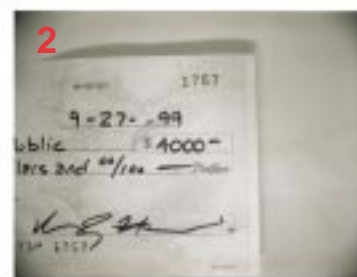

These are the resultant photographs taken with the EV~CAM™ IV:
1) U.S. currency (2) check signature (3) fingerprint on a mug
(4) bottle fingerprints.

CATALOG NO.	DESCRIPTION	PRICE
EVC2000	COMPLETE W/POLAROID 545 FILM HOLDER, 110VAC CHARGER	\$1,095.50
EVC2000220	COMPLETE W/POLAROID 545 FILM HOLDER, 220VAC CHARGER	\$1,122.00

THE EV~CAM™ V EVIDENCE CAMERA

This is the only large format (4" x 5") evidence camera that accommodates Polaroid 4" x 5" professional film packs (eight images per pack). It is exceptionally versatile at the crime scene for all types of 1:1 evidential photography. The large format and film quantity give the crime scene specialist a valuable photographic tool.

Leading Particulars

- Color or black-and-white capability, 4" x 5" format
- No focusing required—fingerprints, photographs, printed pages and other types of evidence are photographed easily
- Continuously variable flash brightness control allows perfectly exposed photographs
- Color/black-and-white switch allows instant switching between the two types of film
- Polaroid film allows the investigator to view and compare the photograph before leaving the crime scene—eliminating guesswork and uncertainty
- Flash intensity is electronically controlled to prevent exposure variations
- State-of-the-art electronic shutter for precise exposures.



No. EVC3000 EV~CAM™ V



These are the resultant photographs taken with the EV~CAM™ V: 1) duct tape prints (pictured above) and 2) CD case prints (pictured below).

EV~CAM™ V Specifications:

Aperture Range: F3.5-F22

Shutter Type: Rotary solenoid

Flash Voltage: 270 volts typical

Charge Current/Right Pack: 110 ma typical (fast charge) 15 ma typical (trickle charge)

Charge Current/Left Pack: 110 ma typical (fast charge) 15 ma typical (trickle charge)

Operating Voltage/Right Pack: 4.8 volts

Operating Voltage/Left Pack: 4.8 volts

Flash Duration: 1/5000 second (full light setting)

Recycle Time: 5-7 seconds typical (black-and-white film)

Battery Charger Input: 12 Volts, 500 ma (AC or DC)

Film Type and Holders: Polaroid pack film, 4" x 5", type 552, type 553 and type 559

CATALOG NO. EVC3000 COMPLETE AS SPECIFIED, 110 VAC CHARGER PRICE: \$984.50
CATALOG NO. EVC3000220 ... COMPLETE AS SPECIFIED, 220 VAC CHARGER ... PRICE: \$1,020.00

LATENT PRINT FORENSIC PHOTOGRAPHY KIT



Leading Particulars

- Select standard 3 1/4" x 4 1/4" or large 4" x 5" format EV~CAM™ cameras
- Instant Polaroid film for instant results
- Master will accommodate additional film
- Kit within a kit to protect the camera
- Color or black-and-white film

This is the complete kit for finding, developing and photographing latent print evidence and other evidential items, such as tool marks, serial numbers, and forgeries. It is a highly functional kit and an excellent choice for crime scene search teams or individual investigators. Instant Polaroid photography gives investigators the ability to view pictures before leaving the crime scene.

Kits consist of:

1-No. 177L kit which consists of:

- 1- No. 101L Silk Black Latent Powder, 2 oz.
- 1- No. 103L Indestructible White Latent Powder, 2 oz.
- 1- No. SG202L Silver/Gray Latent Powder, 2 oz.
- 3- No. 122L1 Kit Size Fiberglas® Latent Print Brushes
- 1- No. 130LT1 Transparent Hinge Lifter, 1 1/2" x 2", 24 each
- 12- No. 130LB1 Black Hinge Lifters, 1 1/2" x 2"
- 12- No. 130LW1 White Hinge Lifters, 1 1/2" x 2"
- 6- No. 131LT1 Transparent Hinge Lifters, 2" x 4"
- 6- No. 131LB1 Black Hinge Lifters, 2" x 4"
- 6- No. 131LW1 White Hinge Lifters, 2" x 4"
- 2- No. 127LW1 White Rubber Lifters, 2" x 4"
- 2- No. 127LB1 Black Rubber Lifters, 2" x 4"
- 1- No. FPT267 Porelon® Fingerprint Pad
- 1- No. FPT2701 Wallet-Type Vinyl Case
- 1- No. FPT270A Elimination Fingerprint Form Pad (50 sheets)
- 1- No. 379M Attached Case Magnifier, 1 3/4" dia.
- 1- No. 603E Evidence Identification Tape, 1" x 500"
- 6- No. 621E1 Evidence Preserver Bags, 4" x 9"
- 9- No. FPT2541 Ink Cleaner Towelettes
- 1- No. 177L1 Professional Carrying Case, Leatherette-Covered with Compartments

Photographic Support Items:

- 1- Type 667 Black/White Polaroid Film (20 exposures/pk)
- 1- No. EPS20W Photo Evidence Rule, Black on White, 100 ea.
- 1- No. EPS20B Photo Evidence Rule, White on Black, 100 ea.
- 1- No. EPS30W Photo Evidence Rule, 6", 10 each
- 1- No. 600E Photo Evidence Rule Tape, 1/2" x 360"
- 1- No. 611E Black Evidence Marker
- 1- No. KCP145 White China Marker

Camera:

- 1- No. EVC1000 EV~CAM™ III Evidence Camera (LPK100 only)
- 1- No. EVC2000 EV~CAM™ IV Evidence Camera (LPK200 only)
- 1- No. EVC3000 EV~CAM™ V Evidence Camera (LPK300 only)

Case:

- 1- No. LPK1001 Master Carrying Case, Vinyl Leatherette-Covered with Steel Reinforced Corners and Hardware, Machined Inserts
Dimensions: 20 7/8" x 13 3/4" x 9 3/4"
Weight: 16.5 lbs

CATALOG NO.	DESCRIPTION	PRICE
LPK100	KIT AS LISTED ABOVE WITH NO. EVC1000 EV~CAM III CAMERA	\$1,096.50
LPK200	KIT AS LISTED ABOVE WITH NO. EVC2000 EV~CAM IV CAMERA	\$1,156.50
LPK300	KIT AS LISTED ABOVE WITH NO. EVC3000 EV~CAM V CAMERA	\$1,186.50

EVIDENTIAL CAMERA ACCESSORIES

EV~CAM™ CAMERA CARRYING CASES



The EV~CAM™ professional carrying cases are designed to accommodate all of the SIRCHIE® EV~CAM™ cameras. Large enough for camera, film and accessories, they are covered in vinyl leatherette with reinforced steel corners. Plastic inserts allow cameras to fit snugly in place. Case dimensions are: 18 3/4" x 12 1/8" x 7 3/4".

CATALOG NO. EVC001 EV~CAM™ III CASE PRICE: \$97.50

CATALOG NO. EVC002 EV~CAM™ IV CASE PRICE: \$99.50

CATALOG NO. EVC003 EV~CAM™ V CASE PRICE: \$107.50

PHOTO EVIDENCE RULES (DISPOSABLE)

These are high-contrast photo rules printed on 110 lb. index card stock, and are available in black or white for use on all color backgrounds. Just place rule next to developed prints and photograph with an EV~CAM™.

CATALOG NO.	DESCRIPTION	PRICE
EPS20W	100 EACH/BLACK ON WHITE	\$12.95
EPS20B	100 EACH/WHITE ON BLACK	\$12.95

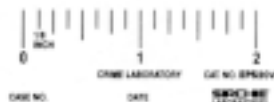

No. EPS20W



No. EPS20B

PHOTO EVIDENCE RULER (VINYL)

These rulers feature metric and English (inch) scales. They are printed on flat-finish, 0.010"-thick vinyl—eliminating reflection. In addition, the user may write on them. Rulers are available in white or blue.

CATALOG NO.	DESCRIPTION	PRICE
EPS30W	WHITE 6" RULER/10 EACH	\$7.50
EPS30B	BLUE 6" RULER/10 EACH	\$7.50

PHOTO EVIDENCE RULE TAPE

When photographing surfaces other than those that are flat, tape is essential to match a curved or irregular surface contour. Resealable adhesive backing permits usage on virtually any type of material, including glass, cloth and paper. Use it when photographing fingerprints, palm prints, signatures, bullet entry and tool marks. The tape is marked in 1/16" increments with 12" repeats in thirty-foot-rolls.

CATALOG NO.	DESCRIPTION	PRICE
600E	1/2" WIDTH ROLL	\$5.25
601E	1" WIDTH ROLL	\$6.50



No. EPS30W



No. EPS30B



No. 600E



No. 601E

4" x 5" STANDARD SHEET FILM HOLDER



This is a highly precise, quality film holder designed for cut film. It features a double-action light trap with die cast film guides and fits the EV~CAM IV evidence camera as well as the No. XZ500CA, No. XZ5000A and No. XZ50001A identification cameras. The holder also fits all other cameras designed for 4" x 5" format cut film holders.

CATALOG NO. 815P PRICE: \$32.95

POLAROID SHEET FILM HOLDER

This Polaroid sheet film holder fits any camera designed for standard 4" x 5" cut film holders. It is an ideal mate to the EV~CAM IV evidence camera as well as the SIRCHIE® No. XZ500CA or SYSTEM No. 5000A/5001A identification cameras.

CATALOG NO. SF545I PRICE: \$269.50



EVIDENTIAL AND CRIMINAL DATA PHOTOGRAPHY



EV~CAM™ III POLAROID PACK FILMS (3 1/4" x 4 1/4" FORMAT)

Three distinctly different films are offered in this format. They will work with the EV~CAM™ III evidence camera and the No. XZ300CA, No. XZ3000A and No. XZ3001A identification cameras. Choose high-speed black-and-white film (type 667), standard high-resolution color film (type 669) or positive/negative black-and-white film (type 665).

CATALOG NO.	FILM DESCRIPTION	EXPOSURES	PRICE
TYPE 669	POLACOLOR ER COLOR: 60 SEC. DEV.	20/PK	\$48.40
TYPE 667	BLACK-AND-WHITE, 3000 SPEED: 30 SEC. DEV.	20/PK	\$35.00
TYPE 665	POSITIVE/NEGATIVE BLACK-AND-WHITE: 30 SEC. DEV.	8/PK	\$18.80

EV~CAM™ IV POLAROID SHEET FILMS (4" x 5" FORMAT)

These Polaroid sheet films work with the Polaroid, No. SF545I sheet film holder (see page 147). A film type for almost any purpose is offered.

- No. TYPE 51: High-contrast black-and-white, 15 second development
- No. TYPE 52: Fine grain black-and-white, 15 second development
- No. TYPE 55: Positive/Negative black-and-white, 20 second development
- No. TYPE 57: 3000 speed black-and-white, 15 second development
- No. TYPE 59: Polacolor ER-60 second development



CATALOG NO.	FILM DESCRIPTION	EXPOSURES	PRICE
TYPE 51	HIGH CONTRAST BLACK-AND-WHITE: 15 SECOND DEV.	20/PK	\$68.54
TYPE 52	FINE GRAIN BLACK-AND-WHITE: 15 SECOND DEV.	20/PK	\$63.14
TYPE 55	POSITIVE/NEGATIVE BLACK-AND-WHITE: 20 SEC. DEV.	20/PK	\$64.17
TYPE 57	3000 SPEED BLACK-AND-WHITE: 15 SECOND DEV.	20/PK	\$64.48
TYPE 59	POLACOLOR ER, COLOR: 60 SECOND DEV.	20/PK	\$92.55

EV~CAM™ V POLAROID PACK FILMS (4" x 5" FORMAT)

Below is a list of 4" x 5" format pack films available from SIRCHIE® for the EV~CAM™ V evidence camera and the No. XZ400CA, No. XZ4000A and the No. XZ4001A identification cameras.

- No. TYPE 572: Fine grain black-and-white, 20 sec. development
- No. TYPE 553: Coaterless black-and-white, 30 sec. development
- No. TYPE 559: Polacolor ER color, 60 sec. development



CATALOG NO.	FILM DESCRIPTION	EXPOSURES	PRICE
TYPE 572	FINE GRAIN BLACK-AND-WHITE: 20 SEC. DEV.	10/PK	\$34.41
TYPE 553	COATERLESS BLACK-AND-WHITE: 30 SEC. DEV.	10/PK	\$34.41
TYPE 559	POLACOLOR ER, COLOR: 60 SEC. DEV.	10/PK	\$47.26

THE SIRCHIE® 1 TO 1 LENS ADAPTER FOR 35 MM SLR CAMERAS

This lens adapter is far above other adapters in both quality and excellence. Exceptional doublet optics assure 1 to 1 ratio photography with a 35 mm SLR camera. To mount, simply screw into the filter mounting threads of a standard 50 mm or 55 mm lens. The transparent acrylic spacer cylinder serves as a camera support and fixed lens to target dimension measure for 1:1 photography. Order the size to fit your 50 mm or 55 mm lens (see page 129 if in doubt).



No. EVD49 adapter

CATALOG NO.	DESCRIPTION	PRICE
EVD49	49 MM DIAMETER LENS ADAPTER	\$59.95
EVD52	52 MM DIAMETER LENS ADAPTER	\$59.95
EVD55	55 MM DIAMETER LENS ADAPTER	\$59.95

THE SPECTRA LAW ENFORCEMENT KIT

The spectra law enforcement kit is the only instant photography system designed especially for use at the crime scene. The kit includes a Polaroid Spectra camera with sonar autofocus, automatic exposure, built-in flash, and a new, light-lock lens that provides clear, consistent 1/2:1 photographs 10 inches from the subject. The kit also includes a 1:1 copy stand and an application video for law enforcement. It all fits into a specially designed, heavy-duty, shock-absorbing carrying case made of durable nylon. The spectra kit uses Polaroid Spectra or type 990 professional instant film.



CATALOG NO. SFPL9182	PRICE: \$269.95
----------------------------	-----------------

UNTIL NOW ...

Personal identification photography in law enforcement was generally accomplished with systems assembled by individual departments, according to their needs. Although adequate, these systems were often dependent on the ability of individual officers, who, in some cases, were not qualified photographers.



SIRCHIE®'s personal identification cameras feature modular, removable electronics control housing for easy separation of the two-camera components to facilitate servicing, if necessary.

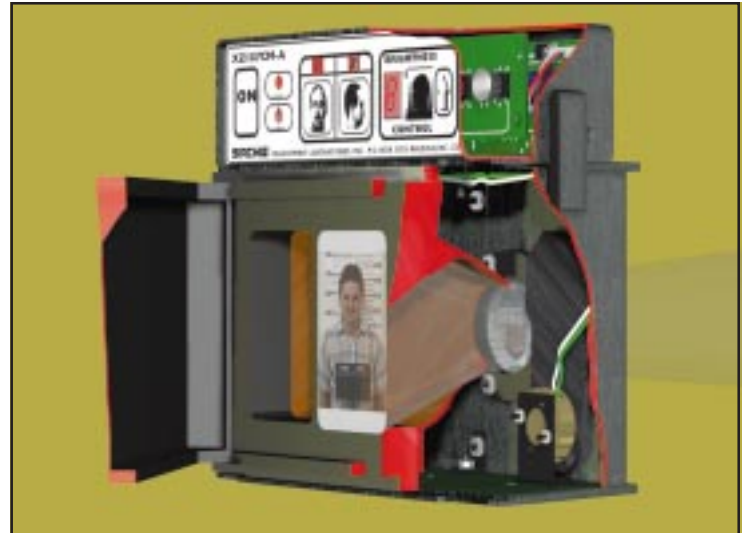

This is a sectional view of the XZ series of personal identification cameras.

NOW ...

SIRCHIE® OFFERS A SYSTEM THAT DOES NOT REQUIRE ANY PHOTOGRAPHIC EXPERIENCE

The SIRCHIE® XZ series of personal identification cameras is the finest line of two-pose identification cameras available anywhere. An 8-bit RISC microcontroller guides the operator every step of the way, greatly reducing the possibility of error. The operator doesn't need any special photographic experience to take excellent quality photographs. Despite the camera's simplistic operation, the operator is in control of the photograph's ultimate quality and brightness. Both lens aperture and electronic flash, light-output are fully adjustable.

SIRCHIE® XZ SERIES CONTROL PANEL WITH FUNCTIONAL DESCRIPTION

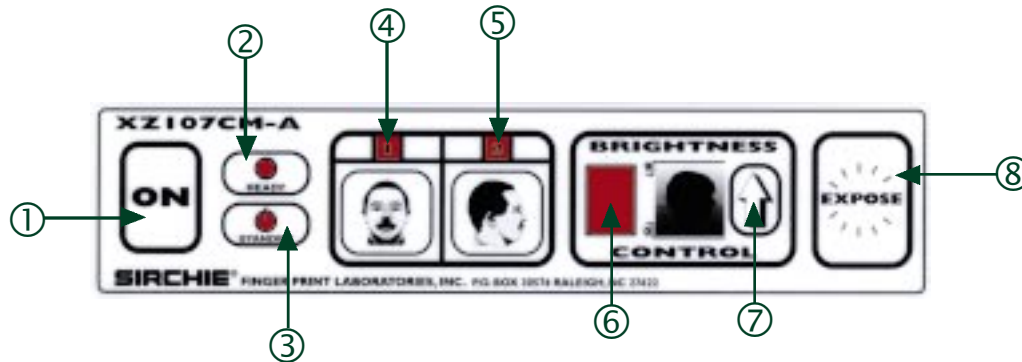

Item	Function
① ON SWITCH	Activates camera cycle
② READY INDICATOR	Flashes when internal flash is ready to take a frame
③ STANDBY INDICATOR	Indicates that the camera is inactive or waiting for flash to charge
④ FRAME #1 INDICATOR	Is lit when the next shot will be the first frame
⑤ FRAME #2 INDICATOR	Is lit when the next shot will be the second frame
⑥ BRIGHTNESS LEVEL DISPLAY	#1 through #9 indicate progressively brighter flash setting, #0 means "no flash"
⑦ BRIGHTNESS LEVEL CONTROL	Push-button touch pad allows the user to set flash level in 10 steps, including no flash
⑧ EXPOSE SWITCH	Touch pad to fire camera shutter

THE NO. XZ300CA PHOTO IDENTIFICATION CAMERA

about THE CAMERA ...

The No. XZ300CA photo identification camera is the most versatile, practical, easy-to-use identification camera ever developed for law enforcement officials. It features a fixed-focus, two-pose electronically controlled shutter for the finest, professional-looking photographs. The camera offers excellent depth-of-field and may be used with black-and-white or color Polaroid film.

No. XZ300CA Leading Particulars

Control Unit

- Code-protected 8-bit RISC microcontroller
- Automatic frame sequencing: Frame 1—Frame 2—Auto shutdown
- Rugged, touch-sensitive power, brightness and shutter switches provide exceptional reliability and environmental resistance
- 3.3 KHz audio tone generator
- Precision-stepped digital flash brightness adjustment
- May be set for use without the internal flash for studios with fixed lighting
- Automatically reverts to standby mode after each use
- Easily separates from camera base for easy servicing

Internal flash

- Fast recycle time: Typically 4 to 6 seconds
- Brightness setting: Stepped voltage control
- Flash voltage regulation: Precisely controlled to within +/- 2.5%
- Flash voltage levels: Digitally stepped from 200 to 300 volt levels
- SCR-controlled discharge

Camera Base

- Uses convenient Polaroid 3 1/4" x 4 1/4" pack film, both color and black-and-white
- Sequential SCR-controlled rotary shutters
- Sturdy, machined-aluminum body
- Self-contained, internal power supply
- Permanently mountable
- Dual electronically controlled rotary shutters
- Dual lens, 105mm f22-f4.5
- Camera assembly reverts to standby mode after use
- Power: 110/120 VAC
- Dimensions: 10 1/8" x 7 1/2" x 6 7/16"
- Weight: 6.6 lbs.
- Film type: Polaroid pack film—type 665, type 667 and type 669 (see page 150)



The front of the No. XZ300CA photo identification camera is pictured above and the rear of the camera is pictured below.

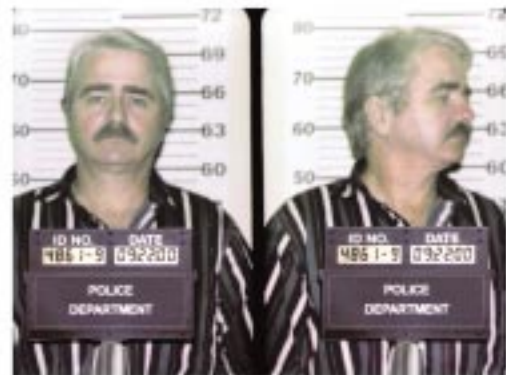

This is the resultant photograph taken with the No. XZ300CA photo identification camera.

CATALOG NO.	DESCRIPTION	PRICE
XZ300CA.....	CAMERA WITH NO. XZ107CMA CONTROL HEAD, 3 1/4" x 4 1/4" FORMAT.....	\$985.00
XZ107CMA.....	CONTROL HEAD.....	\$425.00

NO. XZ400CA PHOTO IDENTIFICATION CAMERA



This is the front of the No. XZ400CA photo identification camera.



This is a rear view of the No. XZ300CA photo identification camera.



This is the resultant photograph taken with the No. XZ400CA photo identification camera.

about THE CAMERA ...

This camera is designed primarily for law enforcement agencies that require a large, 4" x 5" film format utilizing Polaroid instant film pack. It features a fixed-focus (~34"), two-rose, electronically controlled shutter for professional-looking photographs. It offers excellent depth-of-field, and may be used with color or black-and-white Polaroid film.

No. XZ400CA Leading Particulars:

Control Unit

- Code-protected 8-bit RISC microcontroller
- Automatic frame sequencing: Frame 1—Frame 2—Auto shutdown
- Rugged, touch-sensitive power, brightness and shutter switches provide exceptional reliability and environmental resistance
- 3.3 KHz audio tone generator
- Precision-stepped digital flash brightness adjustment
- May be set for use without the internal flash for studios with fixed lighting
- Automatically reverts to standby mode after each use
- Easily separates from camera base for easy servicing

Internal flash

- Fast recycle time: Typically 4 to 6 seconds
- Brightness setting: Stepped voltage control
- Flash voltage regulation: Precisely controlled to within +/- 2.5%
- Flash voltage levels: Digitally stepped from 200 to 300 volt levels
- SCR-controlled discharge

Camera Base

- Accommodates Polaroid 4" x 5" pack film, both color or black-and-white
- Sequential SCR-controlled rotary shutters
- Sturdy, machined-aluminum body
- Self-contained, internal power supply
- Permanently mountable
- Dual electronically controlled rotary shutters
- Dual lens, 105mm f22-f4.5
- Power: 110/120 VAC
- Camera assembly reverts to standby mode after use
- Dimensions: 10 1/8" x 7 1/2" x 6 7/16"
- Weight: 6.6 lbs.
- Film type: Polaroid pack film—type 572, type 553 and type 559 (see page 150)

CATALOG NO.

DESCRIPTION

PRICE

XZ400CA.....	CAMERA WITH NO. XZ107CMA CONTROL HEAD, 4" x 5" FORMAT	\$1,095.00
XZ107CMA.....	CONTROL HEAD	\$425.00

NO. XZ500CA PHOTO IDENTIFICATION CAMERA

about THE CAMERA ...

This camera is designed primarily for law enforcement agencies that require a large, 4" x 5" film format with standard film capabilities (negative) or Polaroid® instant film in sheet form rather than pack. It is engineered for easy use and adaptable to various film requirements. It features a fixed-focus (~34"), two-pose, electronically controlled shutter for professional-looking photographs. It offers excellent depth-of-field, and may be used with color or black-and-white standard sheet film or Polaroid sheet film.

No. XZ500CA Leading Particulars

Control Unit

- Code protected 8-bit RISC microcontroller
- Automatic frame sequencing: Frame 1—Frame 2—Auto shut-down
- Rugged, touch-sensitive power, brightness and shutter switches provide exceptional reliability and environmental resistance
- 3.3 KHz audio tone generator
- Precision-stepped digital flash brightness adjustment
- May be set for use without the internal flash for studios with fixed lighting
- Automatically reverts to standby mode after each use
- Easily separates from camera base for easy servicing

Internal flash

- Fast recycle time: Typically 4 to 6 seconds
- Flash duration: 1/5000 second
- Brightness setting: Stepped voltage control
- Flash voltage regulation: Precisely controlled to within +/- 2.5%
- Flash voltage levels: Digitally stepped from 200 to 300 volt levels
- SCR-controlled discharge

Camera Base

- Accommodates Polaroid 4" x 5" pack film, both color or black-and-white
- Sequential SCR-controlled rotary shutters
- Sturdy, machined-aluminum body
- Self-contained, internal power supply
- Permanently mountable
- Dual electronically controlled rotary shutters
- Dual lens, 105mm f22-f4.5
- Power: 110/120 VAC
- Camera assembly reverts to standby mode after use
- Dimensions: 10 1/8" x 7 1/2" x 6 7/16"
- Weight: 6.2 lbs.

To add Polaroid film processing capability to the No. XZ500CA, see page 147, No. SF545I Polaroid sheet film holder.



This is the front of the No. XZ500CA photo identification camera.



This is a rear view of the No. XZ500CA photo identification camera.



This is the resultant photograph taken with the No. XZ500CA photo identification camera.

CATALOG NO.	DESCRIPTION	PRICE
XZ500CA.....	CAMERA WITH NO. XZ107 CMA CONTROL HEAD*	\$975.00
*ALSO INCLUDES NO. 815P STANDARD 4" x 5" CUT FILM HOLDER		
XZ107CMA.....	CONTROL HEAD	\$425.00

by **SIRCHIE**[®]



about **THE UNIT ...**

This is a complete, totally integrated identification camera stand that offers easy operation and guaranteed performance.

The stand features a four-footed, cast iron base for stabilization and permanent mounting, if necessary. A height-lock mechanism moves vertically and features a Teflon locking collar.

The stand is designed primarily for use with **SIRCHIE**[®]'s identification camera systems, but adapts readily to any 35mm, 70mm, 4" x 5" or 120-roll format-type cameras.

It is an excellent choice for departments not requiring dedicated camera systems.

No. 827P Leading Particulars

- Adaptable to any camera system
- Easily transported to any location
- Set-up time takes only seconds
- Floating action, spring vertical movement
- Rugged construction

This is the No. 827P universal photo identification stand.

CONTINUED

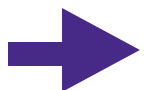

UNIVERSAL PHOTO IDENTIFICATION STAND

No. 827 Specifications:

Height (floor to top of platform):

Min. 47.5"
 Max. 65"
 Total Travel 17.5"

Platform size:

0.75" H x 23.8" W x 11.8" D

Distance from the centerline of the upright tubing to the end of the horizontal arm: 34.5" (special lengths may be ordered)

Manufacturing materials—

- Locking nut:** Aluminum, black anodized
- Handle:** Thermoset plastic, black
- Base:** Cast iron
- Column:** Steel tubing
- Column top:** Cast aluminum, tenz alloy
- Platform head:** Cast aluminum, tenz alloy
- Locking collar:** Teflon
- Arm lock:** Cast aluminum
- Column springs:** Spring steel
- Arm:** Aluminum tubing
- Upright tubes:** Aluminum tubing
- Platform:** Plastic laminated



NEW!

**VERTICAL
 HEIGHT-LOCK
 HANDLE**

An operator adjusts the stand height on the No. 827 universal photo identification stand.

THE UNIVERSAL PHOTO IDENTIFICATION STAND ...

is available in three different configurations so a department may choose or adapt one to meet its specific needs. See below for ordering instructions.

CATALOG NO.	DESCRIPTION	PRICE
827P	STANDARD STAND Identification sign not included	\$494.50
829P	STAND W/ROTARY SIGN Specify sign heading when ordering	\$549.50
830P	STAND W/ELECTRONIC DIGITAL SIGN Specify sign heading when ordering	\$599.50



The electronic digital sign, No. 893PA, is mounted on the universal photo I.D. stand.

EVIDENTIAL AND CRIMINAL DATA PHOTOGRAPHY



SIRCHIE® INTRODUCES ... A NEW GENERATION OF PHOTO IDENTIFICATION SIGNS

This is **SIRCHIE®**'s electronic digital identification sign. Designed and engineered by **SIRCHIE®**, the sign offers convenience and reliability. The unit features a dual bank of liquid crystal displays known for their photographic compatibility.

about THE IDENTIFICATION SIGN ...

The sign is simple to use and features a swing-down front panel for rapid access to the entry keyboard. Simply touch the key number desired—there are no knobs to turn and no numbers to insert.



The electronic identification sign, No. 893PA, is used in typical mugshot photos like this one.

No. 893PA Specifications:

- All CMOS circuitry
- 8-BIT microprocessor controlled
- 2048-byte EPROM
- 32-byte RAM
- 3.579 Mhz clock rate
- 15 ma current maximum drain during data entry
- 2.5 ma maximum standby current drain
- Powered by 4 internal "AA" Alkaline batteries, accessible through battery cover
- Expected battery life (continuous-ON under normal use) in excess of 725 hours

No. 893PA Leading Particulars

- Liquid crystal display (dual)
- 12 digits total—6 each bank
- Character height—.750"
- Contrast ratio—20:1
- Operating life—100,000 hours
- Mounting option included:
 - A. Detachable neck chain
 - B. Camera stand bracket
- Physical dimensions:
 - Size: 6" H x 9" W x 1 1/4" D
 - Weight: 1 1/2 lbs.



No. 893PA access door opened

The number and date are easy to enter on the No. 893PA's keyboard. It takes only seconds to enter the data. Close the access door and it's ready to go.

CATALOG NO. 893PA ELECTRONIC DIGITAL MUG SIGN PRICE: \$216.95

THE ROTARY IDENTIFICATION SIGN

ONLY by SIRCHIE®

This is **SIRCHIE®**'s most popular identification sign—more than 10,000 are in use throughout the law enforcement community worldwide. The ruggedly constructed sign features replaceable year and number bands for years of continuous service.



Rotating the bands on the No. 837P is easily accomplished from the rear panel.



The rotary identification sign, No. 837P, is used in typical mugshot photos like this one.

Leading Particulars

- .062" and .060" thick 5052-H3 aluminum alloy
- 1/4" diameter CRS thumbwheel support rods
- High-impact ABS plastic injection-molded thumbwheels
- Durable polyurethane textured black finish
- Weight: 1 lbs. 8 oz.
- Dimensions: 9 1/4" W x 5 3/4" H x 1 11/16" D

No. 837P11 Specifications:

- Eleven flexible continuous ring bands constructed of flat black Styrene Butadiene Rubber (SBR)
- Durometer: 50 +/- 5
- Each identification band is independently positioned by an indented thumbwheel control conveniently located in the rear of the unit

Band Size

Numeral bands (6): 3/4" W x .042" thick x 10" C

(White on FLT-BLK .550" H digits numbered 0-9)

Date Bands (4): 1/2" W x .042" thick x 10" C

(White on FLT-BLK .400" H digits numbered 0-9)

Year Band (1): 3/4" W x .042" thick x 10" C

(White on FLT-BLK .400" H digits, current + 10 years)

Numerical ranges

Identification numerals: 0-999999

Mo/Da: 01-31

Year: Current year + 10 years

Department Heading

Character specification

A. Customer-specified up to three lines maximum in 1/2" white characters on flat black background

B. Size: 8 1/8" L x 3 3/8" H

Supplied mounting options

A. Neck chain: 24" long #6 ball chin assembled in comfortable 1/4" diameter clear flexible PVC tubing with quick-release black ABS mounting clips

B. Camera stand mounting bracket: Constructed of .060" thick cold-rolled steel, supplied with all hardware for proper mounting and finished in black polyurethane paint

***NO. 837P11 IS SUPPLIED WITH
6 NUMERAL BANDS, 4 DATE BANDS AND
1 YEAR BAND.**

CATALOG NO.	DESCRIPTION	PRICE
837P	ROTARY I.D. SIGN (SPECIFY HEADING WHEN ORDERING)	\$97.50
837P11	REPLACEMENT BANDS (11)*	\$24.95
837P9	REPLACEMENT YEAR BAND ONLY (CURRENT + 10)	\$9.95

THE ROTARY IDENTIFICATION SIGN



ONLY by SIRCHIE®

This rotary identification sign features a format that allows departments to use the subject's social security number as well as the day, month and year. The sign includes two bands with alphabetical designators (One band has A-M and one band has N-Z). Replaceable number and letter bands are available.

Leading Particulars

- .062" and .060" thick 5052-H3 aluminum alloy
- 1/4" diameter CRS thumbwheel support rods
- High-impact ABS-plastic injection molded thumbwheels
- Durable polyurethane textured black finish
- Weight: 1 lbs. 8 oz.
- Dimensions: 9 1/4" W x 5 3/4" H x 1 11/16" D

No. 837PS Specifications:

- Sixteen flexible continuous ring bands constructed of flat black Styrene Butadiene Rubber (SBR)
- Durometer: 50 +/- 5
- Each identification band is independently positioned by an indented thumbwheel control conveniently located in the rear of the unit



An operator sets the date on the rotary identification sign, No. 837PS.

Band Size

Numeral bands (14): 3/4" W x .042" thick x 10" C
(White on FLT-BLK .550" H digits numbered 0-9)
Letter Bands (2): 1/2" W x .042" thick x 10" C
(White on FLT-BLK .400" H digits numbered 0-9)

Numerical Ranges

Identification numerals: 0-999999
Mo/Da: 01-31, Year: Current year + 10 years

Date Discs

- Six indented positive-locking Mo/Da/Yr discs constructed of .040" thick 5052-H32 aluminum alloy
- Disc size:
Year disc (2), current yr. + 10: 3" dia. (white on FLT-BLK .450" H digits)
Month discs (2), 01-12: 3" dia. (white on FLT-BLK .450" H digits)
Day discs (2), 01-31: 3" dia. (white on FLT-BLK .450" H digits)

Department Heading

Character specification

- Customer-specified up to three lines maximum in 1/2" white characters on flat black background
- Size: 8 1/8" L x 3 3/8" H

Supplied mounting options

- Neck chain: 24" long #6 ball chin assembled in comfortable 1/4" diameter clear flexible PVC tubing with quick-release black ABS mounting clips
- Camera stand mounting bracket: Constructed of .060" thick cold-rolled steel, supplied with all hardware for proper mounting and finished in black polyurethane paint



The rotary identification sign, No. 837PS, is used in typical mugshot photos like this one.

*** NO. 837PS10 IS SUPPLIED WITH 14 NUMERAL BANDS AND 2 LETTER BANDS.**

CATALOG NO.	DESCRIPTION	PRICE
837PS	ROTARY IDENTIFICATION SIGN (SPECIFY HEADING WHEN ORDERING)	\$149.95
837PS10	REPLACEMENT BANDS FOR 837PS, 16 PER SET*	\$29.95

THE HAND-HELD ROTARY IDENTIFICATION SIGN



by **SIRCHIE®**

This is a hand-held version of the popular **SIRCHIE®** No. 837P identification sign. The sign features rugged, knurled-aluminum hand grips and is ideal for processing a large number of subjects. Use it with any type of photo identification system.

Leading Particulars

- .062" and .040" thick 5052-H3 aluminum alloy
- 1/4" diameter CRS thumbwheel support rods
- High-impact ABS plastic injection molded thumbwheels
- Durable polyurethane textured black finish
- Weight: 2 lbs 2 oz.
- Dimensions: 14" W x 5 7/8" H x 1 5/8" D
- Handles
 - .090" thick 5052-H32 aluminum handle mounts
 - .800" diameter knurled handles mounted vertically on two sides constructed of 6061-16 aluminum alloy clear, anodized finished
- Identification bands specifications (see page 159, No. 837P)
- Department heading
 - Character specification
 - A. Customer-specified up to three lines maximum in 1/2" high white characters on flat black background
 - B. Size: 8 1/8" L x 3 3/8" H



This is a typical mugshot photo using the hand-held rotary identification sign, No. 837PH.

CATALOG NO. 837PH HAND-HELD ROTARY IDENTIFICATION SIGN PRICE: \$119.50
SPECIFY HEADING WHEN ORDERING

THE REGULAR IDENTIFICATION SIGN

The regular identification sign is an economical, popular photo identification sign. It features a grooved, black felt surface that permits rapid interchanging of arrest numbers and dates.



This is a typical mugshot photo using the regular identification sign, No. 839P.



Leading Particulars

- 5/8" thick wood-embossed in jet black felt
- Grooved for easy numeral/letter insertion
- Extruded aluminum end caps with clear anodized finish
- Dimensions: 8" H x 4" D x 5/8" thick
- Weight: 12 ounces
- Numeral Specifications:
 - A. Six sets 1" high white plastic numerals of 0-9 designation—60 total
 - B. Four sets 1/2" high white plastic numerals of 0-9 designation—40 total
- Department Heading: 3/8" high white characters installed to customer request, 15 characters maximum per line (two lines maximum)
- Supplied neck chain mounting: #6 ball chain 24" long, attached to the mug sign by two chain retention clips (mounted). Allows for adjustment in chain length

CATALOG NO. 839P REGULAR IDENTIFICATION SIGN PRICE: \$46.95
SPECIFY HEADING WHEN ORDERING

THE BUREAU IDENTIFICATION SIGN

This is a large identification sign that measures 6" x 10" and provides ample space for additional personal identification fields that may be needed. A grooved, jet black felt surface permits the rapid interchanging of numbers and dates. Extra numbers and letters may be ordered.

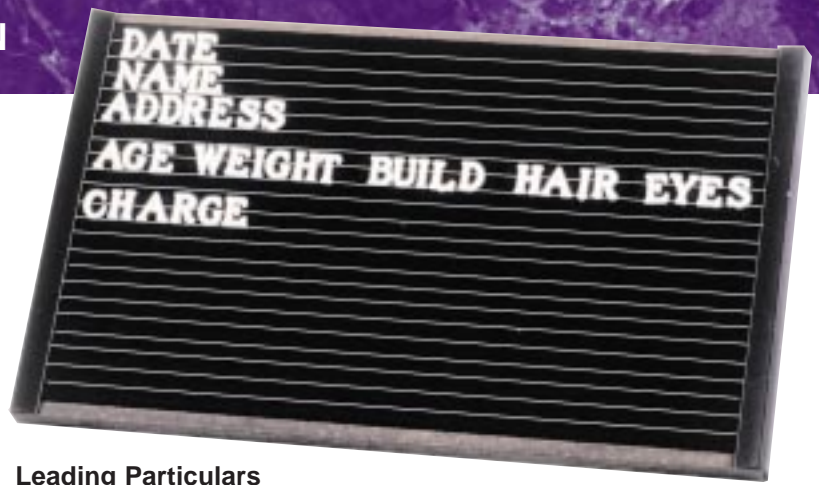

This is a typical mugshot photo using the bureau identification sign, No. 840P.

Leading Particulars

- 5/8" wood embossed in black felt
- Grooved for easy numeral/letter insertion
- Extruded aluminum end caps with clear anodized finish
- Dimensions: 10" H x 6" D x 5/8" thick
- Weight: 1 lb.
- Numeral specifications
 - A. Ten sets 1" high white plastic numerals of 0-9 designation—100 total
 - B. Six sets 1/2" high white plastic numerals of 0-9 designation—60 total
- Field headings: 3/8" high white characters installed as shown in picture
- Supplied neck chain mounting: #6 ball chain 24" long, attached to the mug sign by two chain retention clips (mounted)—allows for adjustment in chain length

CATALOG NO. 840P BUREAU IDENTIFICATION SIGN, 6" x 10" PRICE: \$64.95

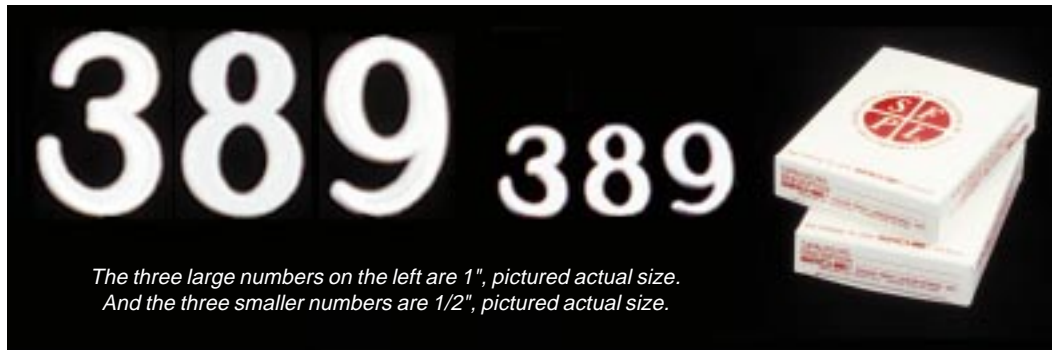

The three large numbers on the left are 1", pictured actual size. And the three smaller numbers are 1/2", pictured actual size.

REPLACEMENT NUMERALS AND LETTERS

These are replacement numerals and letters for **SIRCHIE**®'s No. 839P and No. 840P identification signs, and they are available in three sizes.

CATALOG NO.	DESCRIPTION	SIZE	QUANTITY	PRICE
840P101	NUMERAL, 0-9	1"	1 EA. (10)	\$5.50
840P102	NUMERAL, 0-9	1/2"	1 EA. (10)	\$5.50
840P103	LETTER, A-Z	1"	1 EA. (26)	\$14.50
840P104	LETTER, A-Z	1/2"	1 EA. (26)	\$14.50
840P105	LETTER, A-Z	3/8"	1 EA. (26)	\$14.50
840P100.1	NUMERAL, 0-9	1"	10 EA. (100)	\$37.95
840P100.5	NUMERAL, 0-9	1/2"	10 EA. (100)	\$37.95

the **SYSTEM 3000**

(3 1/4" x 4 1/4" Polaroid Pack Film)

about **THE SYSTEM ...**

The system features a fixed-focus, dual-lens system that is controlled by a micro processor and produces professional identification photographs.

Leading Particulars

- Uses Polaroid 3 1/4" x 4 1/4" pack film, black-and-white—with or without negative, and color (see page 150)
- Quality dual optic system with electronically controlled shutter
- Once in place and operational, the only adjustment required is horizontal height (to accommodate for the subject's height)—release and lock in seconds
- Automatic frame advancement
- Automatic system shutdown after use
- Simple, reliable operation
- Microprocessor-controlled camera

No. System 3000 consists of:

- 1-No. XZ300CA photo identification camera complete with dual lens camera, Polaroid 3 1/4" x 4 1/4" pack back and No. XZ107CM electronic flash and control head (see page 153)
- 1-No. 827P Standard Photo Identification Stand (see pages 156 and 157)
- 1-Photo Identification Sign; choose—
Option A: No. 837P Rotary I.D. Sign (see page 159)
Option B: No. 893PA Electronic I.D. Sign (see page 158)



This is the SYSTEM 3000 assembly.

ORDERING INFORMATION
A. NO. XZ3000A

This system is complete with the components described above with Option A, No. 837P rotary I.D. sign. Specify sign heading.

B. NO. XZ3001A

This system is a complete with the components described above with Option B, No. 893PA rotary I.D. sign. Specify sign heading.



This is the SYSTEM 3000 in use.

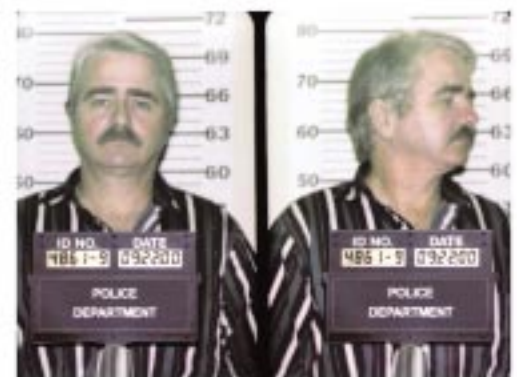

This is a mugshot taken with the SYSTEM 3000.

CATALOG NO.	DESCRIPTION	PRICE
XZ3000A	IDENTIFICATION CAMERA SYSTEM (W/837P ID SIGN)	\$1,396.00
XZ3001A	IDENTIFICATION CAMERA SYSTEM (W/893PA ID SIGN)	\$1,496.00



This is the SYSTEM 4000 assembly.

the **SYSTEM 4000**

(4" x 5" Polaroid Pack Film)

about **THE SYSTEM ...**

The system features a fixed-focus, dual-lens system that is controlled by a micro processor and produces professional identification photographs.

Leading Particulars

- Uses Polaroid 4" x 5" pack film, black-and-white or color (see page 150)
- Quality dual optic system with electronically controlled shutter
- Once in place and operational, the only adjustment required is horizontal height (to accommodate for the subject's height)—release and lock in seconds
- Automatic frame advancement
- Automatic system shutdown after use
- Simple, reliable operation
- Microprocessor-controlled camera

No. System 4000 consists of:

- 1-No. XZ400CA Photo Identification Camera complete with dual lens camera, Polaroid 4" x 5" pack back and No. XZ107CM electronic flash and control head (see page 152)
- 1-No. 827P Standard Photo Identification Stand (see pages 156 and 157)
- 1-Photo Identification Sign; choose—
 - Option A: No. 837P Rotary I.D. Sign (see page 159)
 - Option B: No. 893PA Electronic I.D. Sign (see page 158)



This is a mugshot taken with the SYSTEM 4000.



This is the SYSTEM 4000 in use.

ORDERING INFORMATION
A. NO. XZ4000A

This system is complete with the components described above with Option A, No. 837P Rotary I.D. sign. Specify sign heading.

B. NO. XZ4001A

This system is a complete with the components described above with Option B, No. 893PA Rotary I.D. sign. Specify sign heading.

CATALOG NO.	DESCRIPTION	PRICE
XZ4000A	IDENTIFICATION CAMERA SYSTEM (W/837P ID SIGN)	\$1,496.00
XZ4001A	IDENTIFICATION CAMERA SYSTEM (W/893PA ID SIGN)	\$1,596.00



*This is the
SYSTEM 5000 assembly.*

the **SYSTEM 5000**

(4" x 5" Standard Film or Polaroid Sheet Film)

about **THE SYSTEM ...**

The system features a fixed-focus, dual-lens system that is controlled by a micro processor and produces professional identification photographs.

Leading Particulars

- Uses standard 4" x 5", black-and-white or color, negative film with standard film holder
- With addition of optional Polaroid sheet film holder, camera will accept Polaroid black-and-white, with or without negative and color film (see page 150)
- Quality dual optic system with electronically controlled shutter
- Once in place and operational, the only single adjustment required is horizontal height (to accommodate for the subject's height)—release and lock in seconds
- Automatic frame advancement
- Automatic system shutdown after use
- Simple, reliable operation
- Microprocessor-controlled camera

No. System 5000 consists of:

- 1-No. XZ500CA Photo Identification Camera complete with dual lens camera, Polaroid 4" x 5" pack back and No. XZ107CM electronic flash and control head (see page 152)
- 1-No. 827P Standard Photo Identification Stand (see pages 156 and 157)
- 1-Photo Identification Sign; choose—
Option A: No. 837P Rotary I.D. Sign (see page 159)
Option B: No. 893PA Electronic I.D. Sign (see page 158)

To add Polaroid film processing capability to the SYSTEM 5000, see page 150, No. SF545I Polaroid sheet film holder.



This is a mugshot taken with the SYSTEM 5000 photo identification system.

ORDERING INFORMATION

A. NO. XZ5000A

This system is a complete with the components described above with Option A, No. 837P rotary I.D. sign. Specify sign heading.

B. NO. XZ5001A

This system is a complete with the components described above with Option B, No. 893PA electronic I.D. sign. Specify sign heading.

CATALOG NO.	DESCRIPTION	PRICE
XZ5000A	IDENTIFICATION CAMERA SYSTEM, (W/NO. 837P SIGN)	\$1,325.00
XZ5001A	IDENTIFICATION CAMERA SYSTEM, (W/NO. 893PA SIGN)	\$1,425.00

EVIDENTIAL AND CRIMINAL DATA PHOTOGRAPHY

SIRCHIE® VISIBLE FILING SYSTEM (ROGUES GALLERY)

Locate cards instantly. Secure information at a glance with the rogues gallery visible filing system. The cards with photos are held in transparent pockets for fast reference. The underside of each pocket holds a second card. Pockets are die cut to accommodate the No. FT386 rogues gallery record cards. Cabinets may be stacked as the system data increases.



Leading Particulars

- **SIRCHIE®** rogues gallery filing system accommodates the **SIRCHIE®** rogues gallery record card, No. FT286A, or any 3" x 5", 4" x 5" and 5" x 8" card
- Construction: Heavy-gauge steel
- Finish: Gray enamel
- Stacking: Indented top locators for custom stacking

CATALOG NO.	DESCRIPTION	PRICE
-------------	-------------	-------

FT3841	6-DRAWER	
	\$401.50	
	with 240 pockets and 240 No. FT386A rogues gallery cards (<i>will accommodate 480 cards</i>)	
	10 1/2" W x 16" D x 9" H—cabinet dimensions	

Name	No.	Dept.	Inspector
Grade		alias	
Address			
When Arrested	Previous Arrests	Color	Hgt.
		Hair	Eyes
		Nationality	
		Complexion	Build
		Date of Birth	
		Mark or Scar	
		Occupation	
		Religion	
		Associates	
		Criminal Specialty	
		Remarks	
		F. P. Class	
		Name	No.

ROGUES GALLERY RECORD CARDS

These are standard, 5" x 8" identification format cards printed on heavy-duty, die-cut card stock for filing. The cards feature die-cut slots to accommodate either 3 1/4" x 4 1/4" or 4" x 5" photographs.

CATALOG NO.	ROGUE'S GALLERY RECORD CARDS	PRICE
FT3860	PER 500	\$49.95
FT386	PER 1000	\$96.00
FT3861	PER 3000	\$176.00

PORTABLE ROGUES GALLERY

The portable rogues gallery is outstanding for use when interviewing victims or witnesses in the field. Simply remove the photos of suspects who fit the M.O. of a particular crime and insert them in the gallery's transparent sleeves. The gallery features heavy-duty transparent window sleeves mounted with wire to a heavy-duty russhide black binder/cover. The rogues gallery is supplied with a single tray of 50 sleeves which will accommodate 100 4" x 5" photographs. An additional tray of 50 sleeves, No. SLX24651, also is available.



The portable rogues gallery, No. SLX24650, is opened for viewing mugshots.



The portable rogues gallery is closed.



CATALOG NO.	DESCRIPTION	PRICE
SLX24650	PORTABLE ROGUE'S GALLERY	\$49.50
SLX24651	ADDITIONAL 50-SLEEVE TRAY	\$29.50

IDENTIFICATION HEIGHT SCREEN

Use the identification height screen with any photographic identification system. It is printed in black with metric and English measurement graduations on a white background. The screen is available pre-mounted on a 32" x 21" x 0.125" rugged backing or unmounted.

CATALOG NO.	DESCRIPTION	PRICE
846P	MOUNTED SCREEN	\$49.95
846A	UNMOUNTED SCREEN	\$19.95

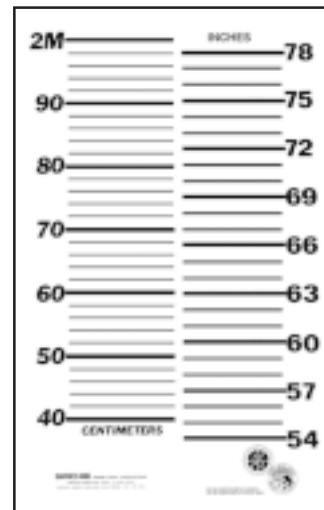

PHOTOGRAPH SCALES, MARKERS AND IDENTIFIERS

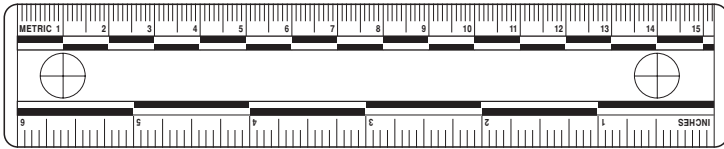

No. PPS400

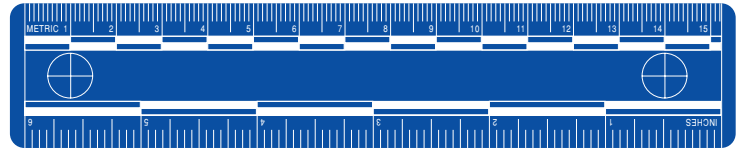

No. PPS402

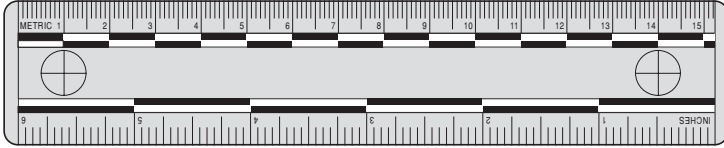

No. PPS401

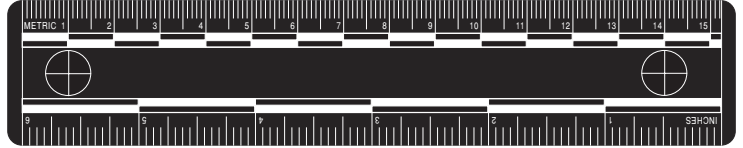

No. PPS403

PHOTO EVIDENCE SCALES

Use **SIRCHIE**'s 6" vinyl scales when photographing evidence for precise measurements. The scales are 0.020" thick, and calibrated in both inches and millimeters and feature crosshairs at each end. The scales also feature a flat finish which eliminates reflections. Scales are packaged in quantities of ten.

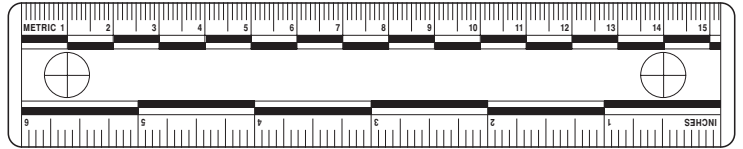

No. PPS404

CATALOG NO.	DESCRIPTION	PRICE
PPS400	RULER, WHITE WITH BLACK PRINTING, 10 EACH	\$9.95
PPS401	RULER, GRAY WITH BLACK PRINTING, 10 EACH	\$9.95
PPS402	RULER, BLUE WITH WHITE PRINTING, 10 EACH	\$9.95
PPS403	RULER, BLACK WITH WHITE PRINTING, 10 EACH	\$9.95
PPS404	RULER, TRANSPARENT WITH BLACK PRINTING, 10 EACH	\$9.95

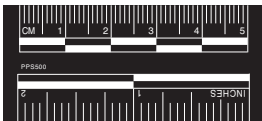

No. PPS500

PHOTO EVIDENCE SCALES (ADHESIVE BACK)

These scales are 2"/50 mm wide and are printed on flat, pressure-sensitive paper with a non-permanent adhesive back. Use them on vertical or horizontal surfaces. Fingerprints, traces of blood and bullet holes are easily measured for photographic purposes.



No. PPS502

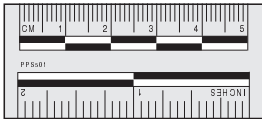

No. PPS501



No. PPS503 (Roll)

CATALOG NO.	SCALE DESCRIPTION	PRICE
PPS500	BLACK SCALE WITH WHITE PRINTING, 50 EACH	\$6.50
PPS501	GRAY SCALE WITH BLACK PRINTING, 50 EACH	\$6.50
PPS502	WHITE SCALE WITH BLACK PRINTING, 50 EACH	\$6.50
PPS503	WHITE SCALE WITH BLACK PRINTING, ROLL OF 150	\$12.95

PHOTO EVIDENCE SCALES (35 mm PHOTOS)

Always use these sales when photographing evidence at a 1:1 ratio with 35mm film. The scales feature a non-permanent adhesive back that may be used on, and easily removed from horizontal and vertical surfaces.

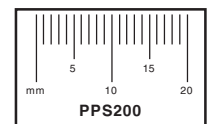

No. PPS200
actual size

CATALOG NO.	DESCRIPTION	PRICE
PPS200	20 mm SCALES, ROLL OF 150	\$9.95

PHOTOGRAPH SCALES, MARKERS AND IDENTIFIERS

PHOTO EVIDENCE RULER (VINYL)

These rulers are printed with both English and metric measurements. They are printed on a flat-finish vinyl. This surface eliminates photographic reflections and may be written on. Rulers are 6" x 0.010" thick and are available in white or blue.

CATALOG NO.	DESCRIPTION	PRICE
EPS30W	WHITE RULERS	\$7.50/10
EPS30B	BLUE RULERS	\$7.50/10

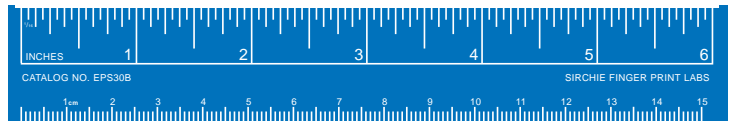

No. EPS30B

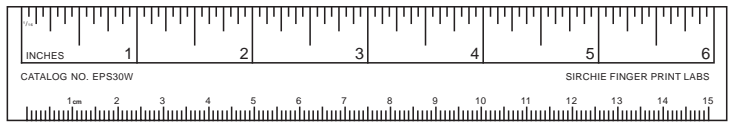

No. EPS30W

PHOTO EVIDENCE RULES (DISPOSABLE)

These high-contrast photo rules are printed on 110 lb. index card stock with a non-adhesive back in contrasting black, white or gray for use on all color backgrounds. Lay next to developed prints and photograph with an EV-CAM™ fingerprint camera.

CATALOG NO.	DESCRIPTION	PRICE
EPS20W	BLACK ON WHITE	\$12.95/100
EPS20B	WHITE ON BLACK	\$12.95/100
EPS20G	BLACK ON GRAY	\$12.95/100



No. EPS20G

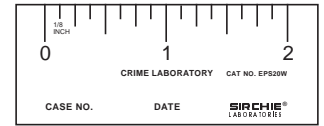

No. EPS20W



No. EPS20B

EVIDENCE PHOTOGRAPH	CATALOG NO. EP3
Case No. _____	Photo No. _____
Location _____	
Date _____	Time _____
Camera Height _____	Lens-Subject Dist. _____
Camera Type _____	Shutter Speed _____
f stop _____	Film Type _____ ISO _____
Weather _____	Lighting _____
Photographer (s) _____	
SIRCHIE® FINGER PRINT LABORATORIES, INC. 100 HUNTER PLACE YOUNGSVILLE, N.C. 27596 PHONE: (919) 554-2244 • (800) 356-7311 FAX: (919) 554-2266 • (800) 899-8181	

PHOTOGRAPHY EVIDENCE LABELS

These labels feature a pressure-sensitive backing that may be attached to evidence or used as free-standing identification for photographic purposes. All relevant information including how, when, where and conditions may be noted to establish the permanent history of the object. Dimensions: 4" x 2 3/4".

CATALOG NO. EP3 PACK OF 100 LABELSPRICE: \$16.50

SEARCH PHOTO EVIDENCE RULE TAPE

SIRCHIE®'s photo evidence rule tape is ideal for unusual surface shapes. It may be applied to almost any surface and is easy to remove after evidence is photographed. The rule tape is printed in 1/16" increments with a 12" repeat. The tape is supplied in 500" rolls on a 1" cores. Measurements are printed in black on white tape. In addition, tape may be custom-printed with a specific agency name. Please specify when ordering.



CATALOG NO.	DESCRIPTION	PRICE
601ED	TAPE WITH NO. 145TW METAL TAPE DISPENSER	\$9.50/ROLL
601E	TAPE ONLY	\$6.50/ROLL
602E	TAPE ONLY WITH DEPARTMENT IMPRINT*	\$8.95/ROLL

*MINIMUM ORDER: 24 ROLLS



PHOTOGRAPH SCALES, MARKERS AND IDENTIFIERS

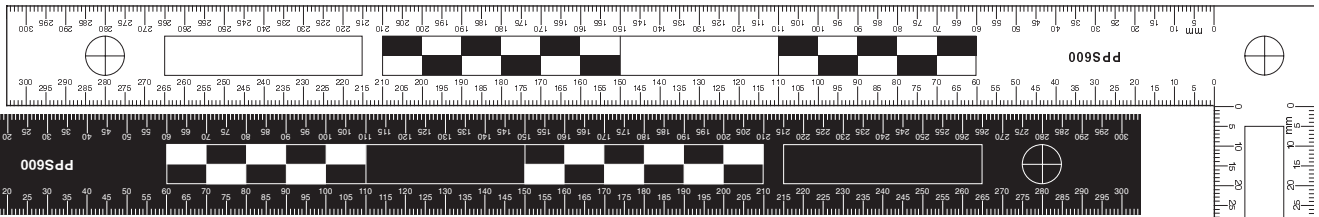

The No. PPS600 is a reversible scale that is white on one side (picture right) and black on the other (picture left).

SCALES IN MACROGRAPHY PHOTOGRAPHY

These scales are designed primarily for footwear and tire track impression comparisons. They are excellent for verifying perspective distortion. The scales are printed on rigid vinyl plastic and feature exceptionally sharp division indicators. They also feature a glare-free finish for photographing in most lighting conditions.

CATALOG NO.	DESCRIPTION	PRICE
PPS600	REVERSIBLE SCALE, 300 x 150 mm	\$9.95
PPS601	REVERSIBLE SCALE, 150 mm	\$5.95
PPS6000	SET OF 2: NO. PPS600 AND NO. PPS601	\$14.95

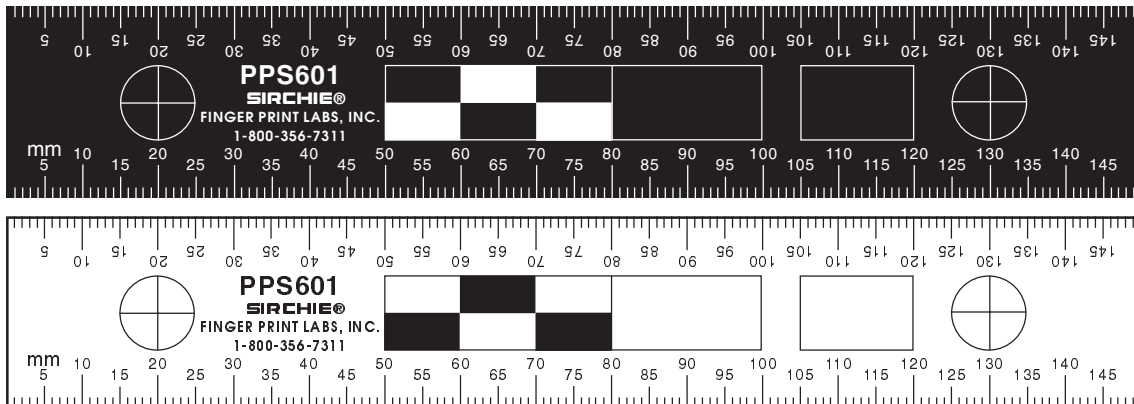

The No. PPS601 is a reversible scale that is white on one side (top picture) and black on the other (bottom picture).

PHOTOGRAPHIC EVIDENCE FOLDING SCALE

These folding scales are a must when photographing evidence such as handprints, footprints, tire tracks and physiological fluid dispersion. When it is opened at a right angle, the scale verifies any departure of the camera from a true vertical or horizontal position. It is constructed of metal for a long life.

Leading Particulars

- Material: Aluminum, 5052 H32, 0.060" thick
- Finish: Matte black anodized
- Indicators: Flat white
- Scaling: 0" x 24" (0 to 60 cm) x 0" x 12" (0 to 30 cm)

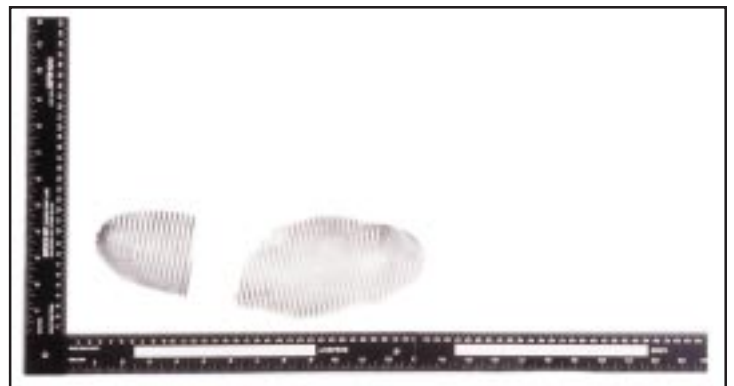
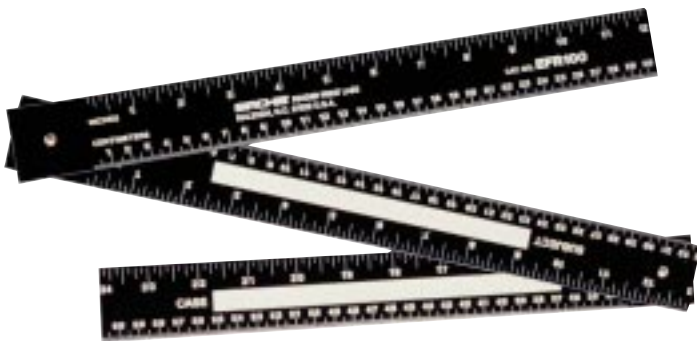

CATALOG NO. EFR100	PRICE: \$19.95
--------------------	----------------

PHOTOGRAPH SCALES, MARKERS AND IDENTIFIERS

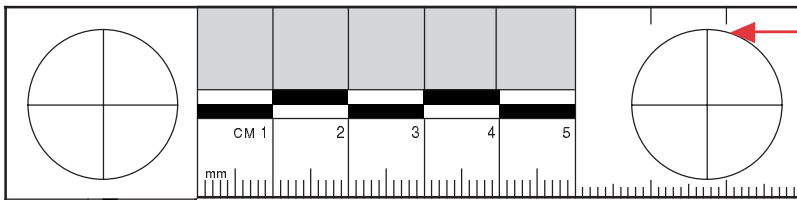

This scale is designed primarily for forensic professionals who are involved with the study of the anatomy, growth and disease of teeth. The scale is printed on rigid vinyl, matte-finish plastic and features superb divisional definition.

CATALOG NO. PPS800 PRICE: \$5.95

No. PPS800 pictured actual size

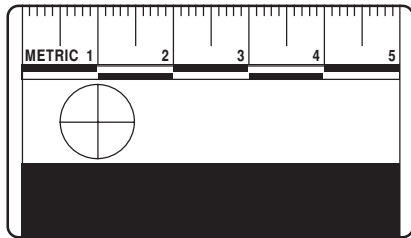
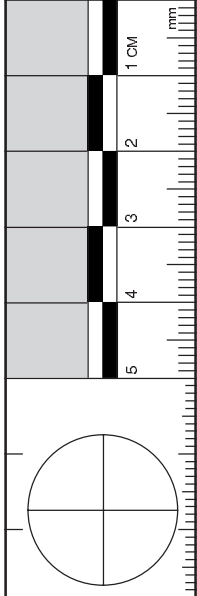

No. PPS301 pictured actual size

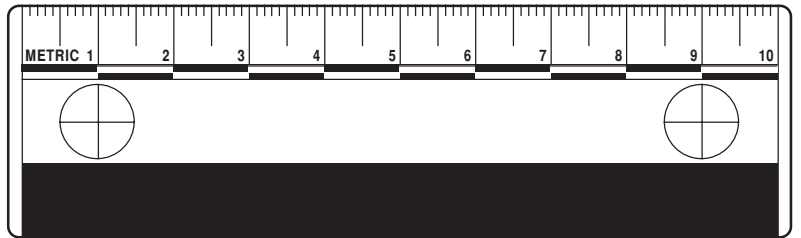

No. PPS300 pictured actual size

These scales are designed for evidential photography. They're printed on rigid vinyl matte-finish plastic for reflection-free photography. The scales are available in two sizes and feature excellent divisional definition.

CATALOG NO. PPS300 10 cm SCALE, PACK OF 10 PRICE: \$7.95

CATALOG NO. PPS301 5 cm SCALE, PACK OF 10 PRICE: \$9.95

JUMBO PHOTO EVIDENCE TAPE, 1 1/4"

This is jumbo tape that features a major number division. The photo evidence tape is yellow with a matte finish. It is printed on a 1 1/4" wide x 30' roll. The scale repeats continuously every 12 inches with an alternating 6" black band on 12-inch divisions. The tape features a low-tact, non-permanent adhesive that allows for easy removal. Use this tape indoors or outdoors.



shown actual size

CATALOG NO. PPS101 JUMBO PHOTO EVIDENCE TAPE, 1 1/4" x 30' PRICE: \$9.95

PHOTO EVIDENCE TAPE, 1"

This tape features a continuous scale repeat of 1" to 12" on a matte, white-finish tape that is 1" wide on a 30-foot roll. The tape features a low-tact, non-permanent adhesive that may be easily removed from any surface without damaging the surface. The tape is printed with divisions for both inches and centimeters.

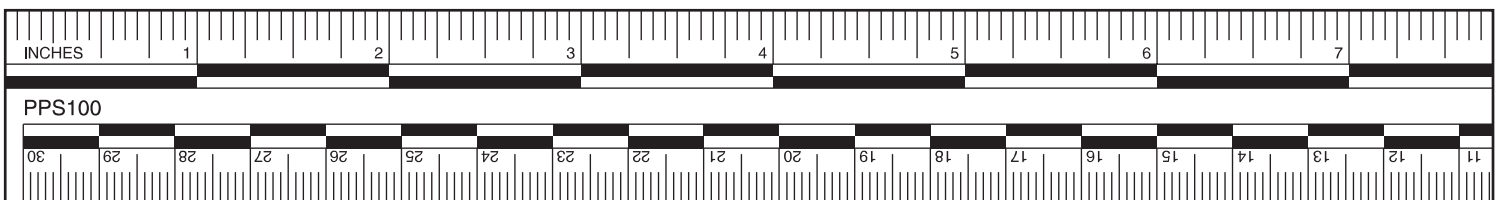

CATALOG NO. PPS100 PHOTO EVIDENCE TAPE, 1" x 30' PRICE: \$7.95

EVIDENTIAL AND CRIMINAL DATA PHOTOGRAPHY

CRIME/ACCIDENT PHOTO EVIDENCE NUMBERS

These are numbered signs for use at crime or accident scenes to indicate the location of relevant evidence. They are fabricated of one-piece 0.032-inch yellow vinyl-clad aluminum for long-life and weight. The numbers feature a matte finish to reduce reflections. Their A-frame form allows for nested storage.

Leading Particulars

Color: Black numeral on yellow background

Material: 0.032" aluminum

Dimensions: 7 1/4" x 4 1/2" x 4 1/4"



CATALOG NO.	DESCRIPTION	PRICE
PEN15	CRIME/ACCIDENT PHOTO NUMBERS, 1 TO 15	\$49.95
PEN1650	CRIME/ACCIDENT PHOTO NUMBERS, 16 TO 50	\$119.50
PEN5199	CRIME/ACCIDENT PHOTO NUMBERS, 51 TO 99	\$196.00

CRIME/ACCIDENT PHOTO EVIDENCE ALPHABET

Use these alphabet signs (A thru Z) with number signs or for designation sequential photography. Fabricated of one-piece 0.032" yellow, vinyl-clad aluminum for long life and weight, they feature a matte finish to reduce reflections. Their A-frame form allows for nested storage (26 units).

Leading Particulars

Color: Black numeral on yellow background

Material: 0.032" aluminum

Dimensions: 7 1/4" x 4 1/2" x 4 1/4"



CATALOG NO. PEA26	PHOTO EVIDENCE LETTERS, A THRU Z	PRICE: \$99.50
-------------------	----------------------------------	----------------

CRIME/ACCIDENT PHOTO DIRECTION INDICATORS

These are orientation indicators to be used in combination with the letter and number indicators. They also may be used above as focus pointers of exceptional evidence items. Their fabrication is the same as numbers and letters indicators. Each set consists of four "UP" indicators, four "DOWN" indicators, four "LEFT/RIGHT" indicators and one "NORTH" indicator.

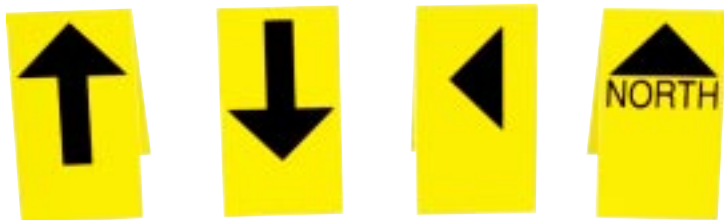

Leading Particulars

Color: Black numeral on yellow background

Material: 0.032" aluminum

Dimensions: 7 1/4" x 4 1/2" x 4 1/4"

CATALOG NO. PDN17	INDICATOR SET	PRICE: \$59.95/13
-------------------	---------------	-------------------

CRIME/ACCIDENT PHOTO LOCATOR CONES

These are multi-purpose cones for use in a variety of situations. They are bright orange/red, and they are available in 6" (15 cm) and 12" (30 cm) height. Cones may be used at crime scenes as evidence markers or for traffic control. They are inexpensive and versatile with black numerals (1 thru 8).

CATALOG NO.	DESCRIPTION	PRICE
CSTC1006	6" CONE, PACK OF 8	\$44.95
CSTC10012	12" CONE, PACK OF 8	\$54.95



PHOTOGRAPH SCALES, MARKERS AND IDENTIFIERS

PHOTOGRAPHY IDENTIFIER BOOKLETS

POSITION •
MEASURE •
PROPORTION •
and IMPORTANCE ...



These are key ingredients for all evidential photography. With **SIRCHIE®**'s identifier booklets, the crime scene photographer's mission is reduced in complexity. Fingerprints, footprints, blood splatters, bullet holes and other physical evidence may be identified, sequenced and oriented. The booklets feature a pressure-sensitive, non-permanent adhesive which permits easy removal from almost any surface.

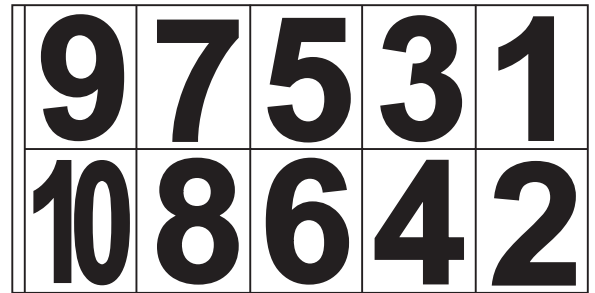

This is the No. PNBL100 (not actual size).
Each individual number size is 2 1/4 x 1 3/4".

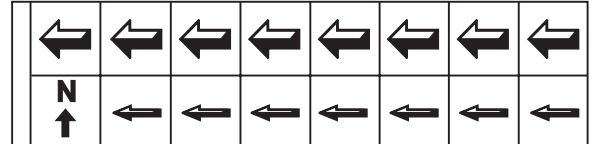

This is the No. PAB100 (not actual size).
Each individual arrow size is 1" x 1".

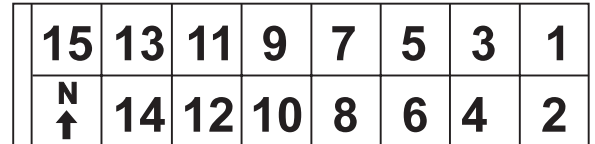

This is the No. PNBS100 (not actual size).
Each individual number size is 1" x 1".

CATALOG NO.

DESCRIPTION

PRICE

PNBL100	NUMBERS BOOKLET, LARGE, 25 SHEETS/BOOK	\$15.95
PNBS100	NUMBERS BOOKLET, SMALL, 25 SHEETS/BOOK	\$10.95
PAB100	ARROWS BOOKLET, LARGE, 25 SHEETS/BOOK	\$10.95

INVESTIGATOR'S MAPPING KIT

This kit is designed to assist the crime scene photographer and the sketch artist. The kit aids in the identifying and mapping of indoor and outdoor locations of pertinent evidence. Unique plastic mapping placards and a specially designed notebook for providing all vital information are included in the kit.



No. SMK1 consists of:

- 1- No. SK900 Metric/English, 100ft/30m Steel Tape Measure
- 10- No. SMK13 Placards, Black with White Numbers, 0-9
- 10- No. SMK14 Placards, White with Black Numbers, 0-9
- 5- SMK15 Placard, Holders
- 1- No. KCP134 Drafting Pencil, Mechanical
- 1- No. GW711 Notebook, Investigator's Model
- 1- No. SMK12 Carrying Case, Molded Copolymer, 16 1/2" x 8 1/2" x 7 1/4"

CATALOG NO. SMK1	INVESTIGATOR'S MAPPING KIT	PRICE: \$69.50
------------------------	----------------------------------	----------------

PHOTOGRAPH DOCUMENTATION KITS

SIRCHIE®'s photograph documentation Kits are designed to meet specific crime scene photographic documentation needs. Component configuration and quantities are offered in a comprehensive manner so that the exigency of a small, medium or large department is satisfied.



MINI PHOTOGRAPHIC DOCUMENTATION KIT (SMALL DEPARTMENTS)

No. PDK100 consists of:

- 1-No. PNBS Photo Numbers Booklet, Small, Adhesive
- 1-No. PPS101 Continuous Photo Scale, Large Number
- 2-No. PPS8001 Photomacrographic Scales
- 3-No. PPS4001 Photographic Rulers, White with Black Printing
- 3-No. PPS4011 Photographic Rulers, Gray with Black Printing
- 2-No. PPS4021 Photographic Rulers, Blue with White Printing
- 2-No. PPS4031 Photographic Rulers, Black with White Printing
- 1-No. PPS100 Continuous Tape Photo Evidence Scale

- 1-No. PAB100 Photo Arrows Booklet, Adhesive
- 1-No. PPS200 20mm Rules, 150/Roll
- 1-No. PPS503 Scales, White with Black Printing, 1" x 2 1/4", 150/Roll
- 1-No. KCP114 Retractable Measuring Tape, 6'
- 1-No. KCP224 Molded Polypropylene Carrying Case, 10 3/8" x 4 5/8" x 1 11/16"

CATALOG NO. PDK100 PRICE: \$79.95

STANDARD PHOTOGRAPHIC DOCUMENTATION KIT (MEDIUM DEPARTMENTS)

No. PDK200 consists of:

- 1-No. PEN15 Crime/Accident Photo Evidence Numbers, 1-15
- 1-No. EFR100 Photo Evidence Ruler, Folding
- 1-No. SK900 Tape Measure 100ft/30m
- 1-No. PNBL100 Photo Numbers Booklet, Large, Adhesive
- 1-No. PNBS100 Photo Numbers Booklet, Small Adhesive
- 1-No. PPS101 Continuous Photo Scale, Large Number
- 2-No. PPS8001 Photomacrographic Scales
- 3-No. PPS4001 Photographic Rulers, White with Black Printing
- 3-No. PPS4011 Photographic Rulers, Gray with Black Printing
- 2-No. PPS4021 Photographic Rulers, Blue with White Printing
- 2-No. PPS4031 Photographic Rulers, Black with White Printing
- 1-No. PPS100 Continuous Tape Photo Evidence Scale



- 1-No. PAB100 Photo Arrows Booklet, Adhesive
- 1-No. PPS200 20mm Rules, 150/Roll
- 1-No. PPS503 Scales, White with Black Printing, 1" x 2 1/4", 150/Roll
- 1-No. KCP114 Retractable Measuring Tape, 6'
- 1-No. KCP224 Molded Polypropylene Carrying Case, 10 3/8" x 4 5/8" x 1 11/16"
- 1-No. PDK2001 Molded, Copolymer Carrying Case with Molded Plastic Inserts, 16 3/8" x 8 5/8" x 7"

CATALOG NO. PDK200 PRICE: \$199.95



**COMPREHENSIVE PHOTOGRAPHIC DOCUMENTATION KIT
(LARGE DEPARTMENTS)**

No. PDK300 consists of:

- 1-No. PEN15 Crime/Accident Photo Evidence Numbers, 1-15
- 1-No. PEN1650 Crime/Accident Photo Evidence Numbers, 16-50
- 1-No. PIC001 Photographic Identifier Cards, Large
- 1-No. EFR100 Photo Evidence Ruler, Folding
- 1-No. PDUP01 Photo Direction Orientator, Up Arrow
- 1-No. PDDOWN02 Photo Direction Orientator, Down Arrow
- 1-No. PDRL03 Photo Direction Orientator, Set of 1 Left Arrow and 1 Right Arrow
- 1-No. PDN04 Photo Direction Orientator, North Arrow
- 1-No. SK900 Tape Measure Metric/Standard, 100ft/30m
- 1-No. PNBL100 Photo Numbers Booklet, Large, Adhesive
- 1-No. PNBS100 Photo Numbers Booklet, Small, Adhesive
- 1-No. PPS101 Continuous Photo Scale, Large Number
- 2-No. PPS8001 Photomacrographic Scales
- 3-No. PPS4001 Photographic Rulers, White with Black Printing
- 3-No. PPS4011 Photographic Rulers, Gray with Black Printing
- 2-No. PPS4021 Photographic Rulers, Blue with White Printing
- 2-No. PPS4031 Photographic Rulers, Black with White Printing
- 1-No. PPS100 Continuous Tape Photo Evidence Scale
- 1-No. PAB100 Photo Arrows Booklet, Adhesive
- 1-No. PPS200 20mm Rules, 150/Roll
- 1-No. PPS503 Scales, White with Black Printing, 1" x 2 1/4", 150/Roll
- 1-No. KCP114 Retractable Measuring Tape, 6'
- 1-No. KCP224 Molded Polypropylene Carrying Case, 10 3/8" x 4 5/8" x 1 11/16"
- 1-No. PDK3002 Molded, Copolymer Carrying Case with Molded Plastic Inserts, 12 1/8" x 7 1/4" x 4 1/2"
- 1-No. PDK3001 Molded, Copolymer Carrying Case with Molded Plastic Inserts, 19" x 11 1/2" x 10 1/2"

CATALOG NO. PDK300 PRICE: \$349.95

SECTION VI TABLE OF CONTENTS

Evidence Collection and Processing

Arson Evidence Collection	208-209
Bags, Paper Evidence	188
Bags, Plastic Evidence	183-187,189
Barrier Tape	177
Body Bags	186
Boxes, Evidence Collection	190
Gas and Vapor Detection	211A-211D
HazMat Kit	211B
Heat Sealers	187
Hydrocarbon Detectors	211
Identification Strips, Evidence	193
Jars, Evidence Collection	191
Kits, Evidence Collection	203, 206-207
Labels, Evidence Identification.	195-197
Markers and Scribers, Evidence	198
Masks, Gas	201A-201B
Metal Detection Sweepers	208
Personal Property Bags	184
Personal Protection	199-201B
Security Signs	177
Shovels, Debris Sifting	208
Sketch Kits	178-179
Tags, Evidence	196
Tape, Evidence	192, 194
Tape Dispenser, Evidence	191B
Tape Measures	181
Templates, Crime Scene	180-181
Tubes, Evidence Collection	191
Vacuums, Evidence	202-205

THE CRIME SCENE ...

- **SECURING**
- **SKETCHING**
- **COLLECTION**
- **IDENTIFICATION AND PRESERVATION OF EVIDENCE**

All criminal investigations are concerned with the dual aspects that create the possibility of physical evidence:

1. the individuals (perpetrator and victim) involved
2. the items employed or touched during the commission of the crime

By its very nature, a crime scene cannot be left untouched by the participants. Physical evidence, in some form, is left behind. The investigators involved should utilize a balanced approach to each inquiry—concerning the collection of the pertinent physical information and formulating connections between that information and the individuals involved in the crime.

The enormous potential of physical evidence must be realized by understanding:

- a. what physical evidence is
- b. how to collect and preserve it
- c. how to determine the pertinent information it offers
- d. how to interpret that information.

This section is concerned with presenting concisely and accurately those essential products and methods which will effectively explicate the systematic process of evidence collection.

SECURE THE CRIME SCENE

Absolutely essential at the outset of any investigation is the securing of the integrity of the crime scene. All too often, investigators arrive at the scene to find the original condition disturbed by family members or bystanders whose often zealous attempts to be helpful destroy valuable evidential items.



CONTROL EVERY SITUATION— WITH BARRIER TAPE FROM SIRCHIE®

Each emergency scene is unique—but each has one requirement in common—CONTROL. Establish and maintain tight control over emergency scene perimeters quickly and efficiently with this brilliant yellow warning tape. Simply tie one end of the tape around a fixed item, walk around the scene's perimeter and tie it off where desired. The tape is available in six formats to accommodate virtually any situation. Eye-catching black lettering is printed on brilliant yellow polyethylene. The tape is three inches (7 1/2 cm) wide by 1,000 feet (300 m) long. The warning repeats every 31 inches. A dispenser box is furnished with each roll.

CATALOG NO.	DESCRIPTION	PRICE
BT100	CRIME SCENE—DO NOT CROSS	\$14.50/ROLL
BT200	POLICE LINE—DO NOT CROSS	\$14.50/ROLL
BT300	SHERIFF LINE—DO NOT CROSS	\$14.50/ROLL
BT400	FIRE LINE—DO NOT CROSS	\$14.50/ROLL
BT500	SECURITY LINE—DO NOT CROSS	\$14.50/ROLL
BT600	CAUTION BIOHAZARD—DO NOT CROSS	\$14.50/ROLL

HIGH-PROFILE CRIME SCENE SECURITY SIGNS

These signs offer an economical and effective means of discouraging curious bystanders assembling at emergency scenes. These attention-getters are a full 11 1/2" x 17" (29 cm x 43 cm), printed bright red on durable 90 lb. (163 g/m²) index card stock. They are easily tacked or stapled into place on string or ropes around the perimeter of the scene. The signs are available in several formats indicating proper jurisdictional authority.

CATALOG NO.	DESCRIPTION	PRICE
CSSSS01	BY AUTHORITY OF POLICE DEPARTMENT	\$27.50/100
CSSSS02	BY AUTHORITY OF SHERIFF'S DEPARTMENT	\$27.50/100
CSSSS03	BY AUTHORITY OF FIRE DEPARTMENT	\$27.50/100
CSSSS04	BY AUTHORITY OF "BLANK" (FILL IN)	\$27.50/100



CRIME SCENE SKETCHING

Sketches at the scene of the crime play a vital role in the investigation. The finished sketch gives a precise and permanent record of the facts found at the scene. A photograph is ordinarily a two-dimensional view of the scene and does not provide accurate information concerning distances between objects that are present at the scene and cannot be clearly understood unless the measured distances between these points are known. A finished drawing or rough sketch of the scene is the simplest and most effective way of showing actual measurements and of identifying important items of evidence at the location of the scene. Sketches are separated into three classes: 1) Rough sketch, 2) Finished sketch and 3) Scale drawing.

ROUGH SKETCH: The rough sketch is prepared by the investigator at the scene—but not until all photography has been completed and before any evidence has been collected. The sketch does not have to be drawn to scale but should include exact measurements of the surroundings and the location of evidence in relation to the victim's location, or other important evidence.

FINISHED SKETCH: The finished sketch is a duplicate of the rough sketch prepared to scale by using layout templates and exact distances. When the finished sketch is completed, it should immediately be duplicated and forwarded to the proper authorities for safekeeping until the case is resolved.

SCALE DRAWING: A scale drawing is used primarily for courtroom presentation. It may be drawn to any scale chosen. The drawing should include all measurements of the rooms, furniture, walls, etc., but not the location of the evidence that has been recovered. When the drawing has been completed, a clear plastic overlay should be attached showing the location of the evidence in the room where it was found.

BASIC CRIME SCENE SKETCH KIT

This kit offers the basic components needed for crime/accident scene sketches at an economical price. All components are self-contained in a quality vinyl binder.



No. DK1 consists of:

- 1-No. TS100 Booklet, "Sketching & Detail Drawing of the Crime Scene"
- 1-No. 376 C-Thru Protractor
- 1-No. CSD11 Crime /Accident Scene Sketch Forms, 50 sheets
- 1-No. CSS11 Crime Scene Sketch Pad, with Forms, Symbols Pre-drawn Diagrams
- 1-No. CST1 Crime Scene Template
- 1-No. KCP134 Mechanical Drafting Pencil
- 1-No. KCP216 Felt-Tip Marker, Medium Point, Black
- 1-No TT1 Traffic Template
- 1-No. DK11 Vinyl Folder with Internal Pockets

CATALOG NO. DK1 PRICE: \$30.95

SQUAD CAR SKETCH KIT

This is the perfect tool for accident and crime scene investigation. This compact kit contains the basic tools necessary for rough and finished sketches. Get economy without sacrificing quality.

No. SK0001 consists of:

- 1-No. KCP130 Pad of Graph Paper, 50 Sheets
- 1-No. KCP131 12" (30 cm) Plastic Ruler
- 1-No. 712 Store Layout Template
- 1-No. 710 Office Plan Template
- 1-No. KCP132 30°/60°/90° Clear Plastic Triangle
- 1-No. KCP133 45°/45°/90° Clear Plastic Triangle
- 1-No. 1190I Lavatory Planning Template
- 1-No. 714 House Furnishings Template
- 1-No. SK0001C Vinyl, Leather-Finish Clipboard Folder
- 1-No. TB100 Booklet, "Sketching: Detail Planning of the Crime Scene"
- 1-No. KCP134 Mechanical Sketch Pencil



CATALOG NO. SK0001 PRICE: \$39.95

MASTER CRIME SCENE SKETCH KIT



This is a complete crime scene sketch kit used by the most progressive police departments worldwide. All the necessary components for quick and professional crime scene sketching are housed in a fold-out briefcase for use in the field or squad room. It is an absolute must for the well-prepared investigator.

No. SK1000 consists of:

- 1-No. KCP130 Pad of Graph Paper, 50 Sheets
- 1-No. KCP131 12" (30 cm) Plastic Ruler
- 1-No. KCP134 Mechanical Sketch Pencil
- 1-No. 1190I Lavatory Planning Template
- 1-No. 714 House Furnishings Template
- 1-No. 712 Store Layout Template
- 1-No. 710 Office Plan Template
- 1-No. KCP135 Universal Compass
- 1-No. SK800 50 ft/15m Steel Rule
- 1-No. KCP136 Set of Professional Drawing Instruments
- 1-No. TB100 "Sketching and Detail Drawing of the Crime Scene" Booklet
- 1-No. KCP132 30°/60°/90° Clear Plastic Triangle
- 1-No. KCP133 45°/45°/90° Clear Plastic Triangle
- 1-No. SK1000C Vinyl, Leather-Finish, Briefcase-Type Carrying Case

CATALOG NO. SK1000 PRICE: \$109.00

PROFESSIONAL CRIME SCENE SKETCH KIT

This professional crime scene sketch kit is designed and outfitted with all the components for quick and professional crime scene sketching. A versatile drawing board allows for on-the-spot sketching, diagramming and drafting. The kit accommodates media sizes up to 11" x 17".



No. SK3000 consists of:

- 1- No. SK3002 Portable Drawing Board
- 1- No. SK3003 Graduated Removable Straight Edge
- 1- No. SK3004 Protractor Drafting Head
- 1- No. SK3005 Reversible Feet (Set)
- 1- No. SK3006 Supplies Storage Pouch
- 10- No. SK3007 Sketching Paper, 11" x 17"
- 1- No. SK3008 Neck Strap
- 1- No. CST1 Crime Scene Template
- 1- No. TT1 Traffic Template
- 1- No. 1190I Lavatory Planning Template
- 1- No. 714 House Furnishings Template
- 1- No. 712 Store Layout Template
- 1- No. 710 Office Plan Template
- 1- No. KCP135 Universal Compass
- 1- No. SK900 100ft/30m Steel Rule
- 1- No. KCP136 Set of Professional Drawing Instruments
- 1- No. TB100 "Sketching and Detail Drawing of the Crime Scene" Booklet
- 1- No. SK3001 Vinyl Carrying Case with Handle

CATALOG NO. SK3000 PRICE: \$288.75

CRIME SCENE TEMPLATES

These templates are designed to make even the most difficult situations simple to diagram—whether it is a crime scene or traffic accident. There is hardly a situation which cannot be drawn quickly, neatly and accurately. These templates are designed to accommodate a ballpoint pen, however a lead pencil and eraser are recommended.

TRAFFIC TEMPLATE

The **SIRCHIE**® traffic template measures 6 1/4" x 3 1/2" and is designed to make drawings of traffic accidents simple and neat. The template enables the user to draw left turn bays; standard and compact autos, station wagons, pickups and vans; cycles; people; trees and ponds; animals; farm tractors; trucks and buses; intersections; fences, rivers and creeks; points of impact and railroad crossings; traffic symbols; and curves.

CATALOG NO. TT1PRICE: \$9.75

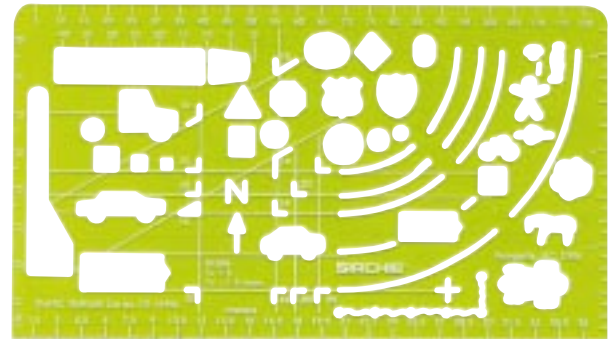

No. TT1

CRIME SCENE TEMPLATE

The **SIRCHIE**® crime scene template, specially created for law enforcement, measures 6" x 3". It is designed to simplify the drawing of difficult objects found at the crime scene. The template features the copyrighted, segmented human body which permits drawing the human form in the exact position in which it was found. The crime scene template is on a quarter-inch scale (1/4" = 1'). There is a conventional 6" ruler along the right side. The bottom and left sides of the template are marked in 1/4" increments. There are many variations for using this template.

CATALOG NO. CST1PRICE: \$9.95

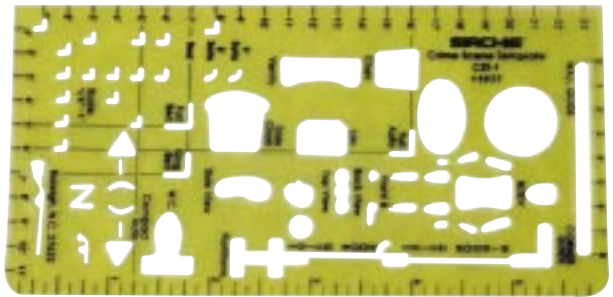

No. CST1

LAVATORY PLANNING TEMPLATE

This template provides an easy way to accurately hand-draw repetitive letters, symbols and shapes. It is made of butyrate plastic and features smooth, friction-free apertures that incorporate a .5mm pencil allowance. It also features the newest symbols for residential, institutional and commercial drawings. The scale is 1/4" : 1' and the template size is 5" x 9" x .030".

CATALOG NO. 1190IPRICE: \$18.25



No. 1190I

HUMAN FIGURE TEMPLATE

The human figure template may be used whenever the drawing of a male or female is required. It measures 8 1/2" x 11" and features holes on the top for placing in a three-ring binder. The scale is 1/4" : 1' and a scale ruler is included on the edge of the template. The human figures are depicted in a variety of heights—with both a front and profile view. A diagram printed on the template illustrates how it is possible to reposition the template during drawing to produce realistic and informative diagrams.

CATALOG NO. HFT1PRICE: \$12.95

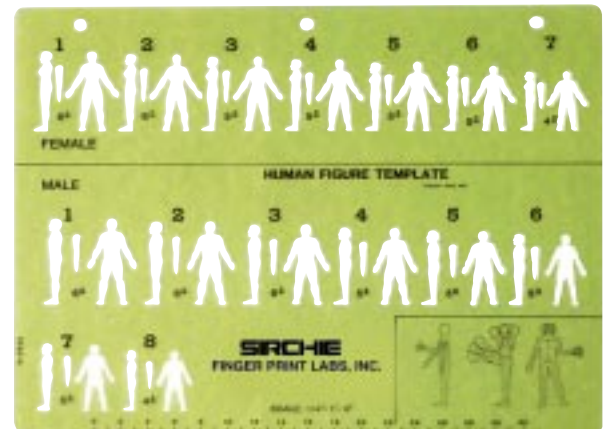

No. HFT1

LATENT PRINT EVIDENCE TEMPLATE

The latent print evidence template features many of the objects from which latent prints may be lifted. A ruler is printed on the top edge of the template. It is made of green buytryate plastic and measures 7 1/2" x 3 5/16". The items featured on this template are the perfect size for drawing on the No. LPW100 or No. LPB100 lifted print backing/sketch/record cards.

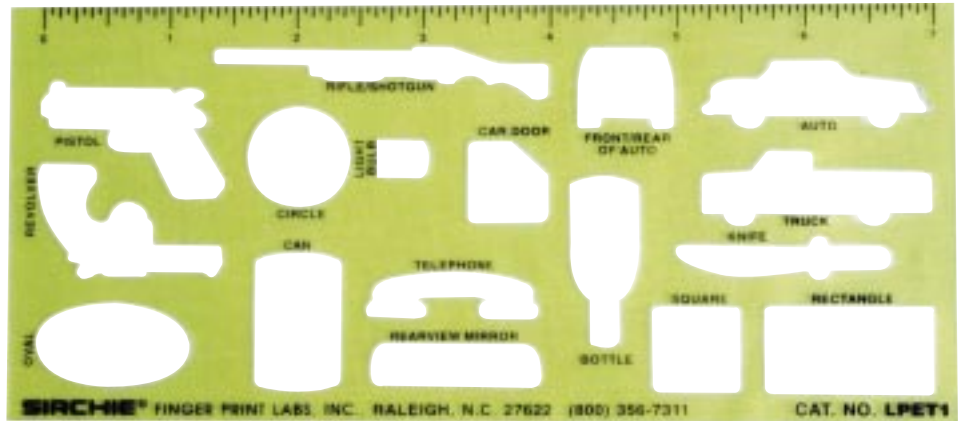

CATALOG NO. LPET1 PRICE: \$9.95

INTERIOR TEMPLATES

These templates are precision-made, feature unique designs, symbols and figures and may offer the most economical, time-saving way to solve an agency's special drawing needs. The templates are made of durable, long-lasting buytryate plastic with a matte-finish on top and a press-polish bottom. The templates are .030" thick and feature a 1/4" : 1' scale. An 8" x 5 1/8" office plan template offers the most standard-sized office furniture and equipment. A 9 1/8" x 5 1/8" store layout template features the most standard-sized counters and tables. The 8 5/8" x 5 1/2" house furnishings template features house furnishings and appliances.

CATALOG NO.	DESCRIPTION	PRICE
710	OFFICE PLAN TEMPLATE	\$18.25
712	STORE LAYOUT TEMPLATE	\$18.25
714	HOUSE FURNISHINGS TEMPLATE	\$18.25

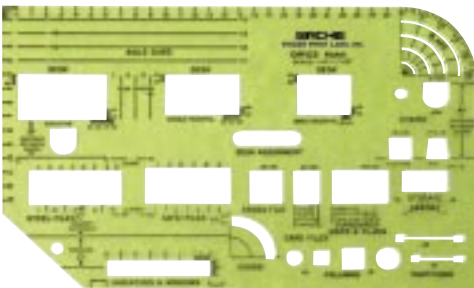

No. 710

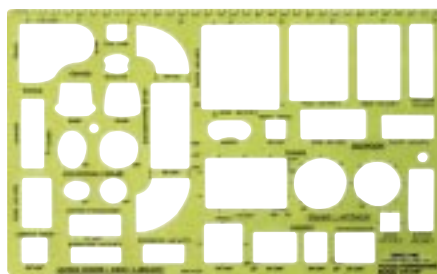

No. 714

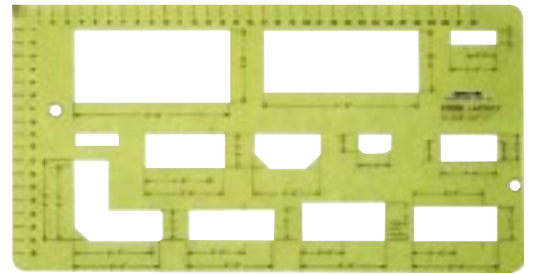

No. 712



No. SK800

No. SK900

PRECISION STEEL TAPE MEASURES

SIRCHIE®'s precision steel tape measures are quality tape measures which are housed in an impact-resistant, fluorescent orange ABS case. Their flexible steel blades are 3/8" wide and feature black and red markings on a yellow background. Each steel blade is covered with polycoat for a longer life. Tape measures come with a handy, folding steel hook designed to fit the hand comfortably while allowing rapid deployment and rewinding.

CATALOG NO. SK800	TAPE MEASURE 50 FT/15 M	PRICE: \$21.95
CATALOG NO. SK900	TAPE MEASURE 100 FT/30 M	PRICE: \$31.95

PROCESSING THE CRIME SCENE

The following is a brief procedural guideline for collecting and preserving physical evidence at the crime scene. Any number of commercially available journals provide excellent detailed information regarding the science of evidence collection. **SIRCHIE**®'s No. TB300, "Evidence Collection Mission" is recommended as an outstanding source of detailed information.

- ◆ **CLEAR THE AREA:** Clear all people (including officers not needed for specific functions) from the crime scene area except essential and authorized personnel. The more people present, the greater the chance of damage to or loss of evidence.
- ◆ **USE A SYSTEMATIC APPROACH:** Use caution when searching for evidence. First, study the crime scene area as a whole because the relationship of different exhibit positions may be important. Systematically cover the crime scene area so that non-obvious or hidden evidence is not overlooked. Speed and carelessness may cause an investigator to overlook, damage or destroy evidence.
- ◆ **LIMIT THE NUMBER OF EVIDENCE COLLECTORS:** Designate one (or at most two) officers to collect all evidence. Limiting the number of evidence collectors places responsibility on specific individuals. It may also avoid confusion later as to who recovered specific items and where the items were found.
- ◆ **PHOTOGRAPH THE EVIDENCE:** Take photographs as necessary prior to moving or securing exhibits.
- ◆ **USE COMMON SENSE:** Rely on knowledge, experience and intelligence when collecting evidence. Consider the significance each exhibit may offer and what examinations the laboratory may conduct. As a result, a trained investigator is normally capable of correctly securing and preserving the exhibits.
- ◆ **KEEP ACCURATE RECORDS:** Prepare notes or other records as items are collected. Record the item, its condition (if appropriate), its exact location relative to a fixed and permanent position, the date, time and other pertinent information.
- ◆ **MARK THE EXHIBITS:** Permanently and distinctively mark objects collected—if it is possible to do so without damaging the evidence.
- ◆ **MARK THE CONTAINERS:** When unable to mark the exhibit itself, such as in the case of stains, hair or paint, place the evidence in a vial or small plastic or paper envelope, seal and mark the container. In fact, it is usually advisable to seal all evidence in some kind of container—even if the exhibit itself is marked—and place additional identification marks on the container.
- ◆ **KEEP THE MARKINGS BRIEF:** Marking the containers with the initials or the name of the officer collecting the evidence is essential. When marking containers, other pertinent data, such as date, location, case number and exhibit description may be included. Do not include extraneous information or investigator conclusions as these might render the label inadmissible as evidence in court.
- ◆ **USE PROPER CONTAINERS:**
 1. Plastic or cellophane envelopes are excellent for small objects which are not organic in nature.
 2. Paper envelopes are used for organic evidence (such as bodily fluids and biological evidence). NOTE: Air dry all evidence before packaging. Seal all corners adequately if very small or powdery material is enclosed. It is preferable to place the latter in plastic envelopes. Do not use paper envelopes for fiber evidence as the paper itself may contain fibers and will contaminate the evidence.
 3. Vials, pill boxes, capsules and similar containers are frequently suitable depending upon the exhibit and its condition.
 4. Garments and large exhibits may be placed in bags or rolled in paper.
 5. Plastic bags/envelopes may be sealed with tape around the ends of large exhibits, such as tools, to prevent the loss of adhering evidence.
 6. The loss of adhering evidence on large exhibits, such as safes and vehicle bumpers may be prevented by placing plastic over the evidence and sealing it with tape.
 7. ALWAYS use new and clean containers to prevent contamination
 8. Never use gummed tape to pick up evidence (See repulpable evidence tape, page 205).
- ◆ **PROPERLY SEAL CONTAINERS:** Preventing loss of evidence, contamination or access by unauthorized people is of primary importance. Do not overseal and complicate the opening of the container in the laboratory. Avoid or limit the use of staples. NEVER staple plastic containers if fine particles of material are enclosed because staples rip small holes in plastic.
- ◆ **KEEP EXHIBITS SEPARATE:** Each different item or similar items secured at different locations should be placed in separate containers. Packaging items separately prevents damage through contact and cross-contamination.
- ◆ **STORE EVIDENCE SECURELY:** Always store evidence in a safe, vault, locker or location where others will not have access to it—including temporary and long-term storage.
- ◆ **KEEP THE CHAIN OF POSSESSION SHORT:** Each individual who has an evidence item in his or her possession—even if in a sealed container—may be required to testify about the item. To save time and to avoid confusion, keep the chain of possession as short as possible. Nevertheless, each person who has the exhibit in his or her possession should mark it on the container if the exhibit is sealed in one.

INTEGRITY EVIDENCE BAGS

The manner in which evidence is stored and protected can often mean the difference between conviction and acquittal. With this in mind, **SIRCHIE®** introduces the integrity evidence bag.

These all-in-one bags are waterproof, tear/puncture-resistant, printable and include a tamperproof seal. No other evidence bag offers greater integrity, security and convenience.

FEATURES:

- WATERPROOF
- TAMPERPROOF
- SEE-THROUGH
- TEAR RESISTANT
- PRINTABLE
- SELF-SEALING
- PUNCTURE RESISTANT

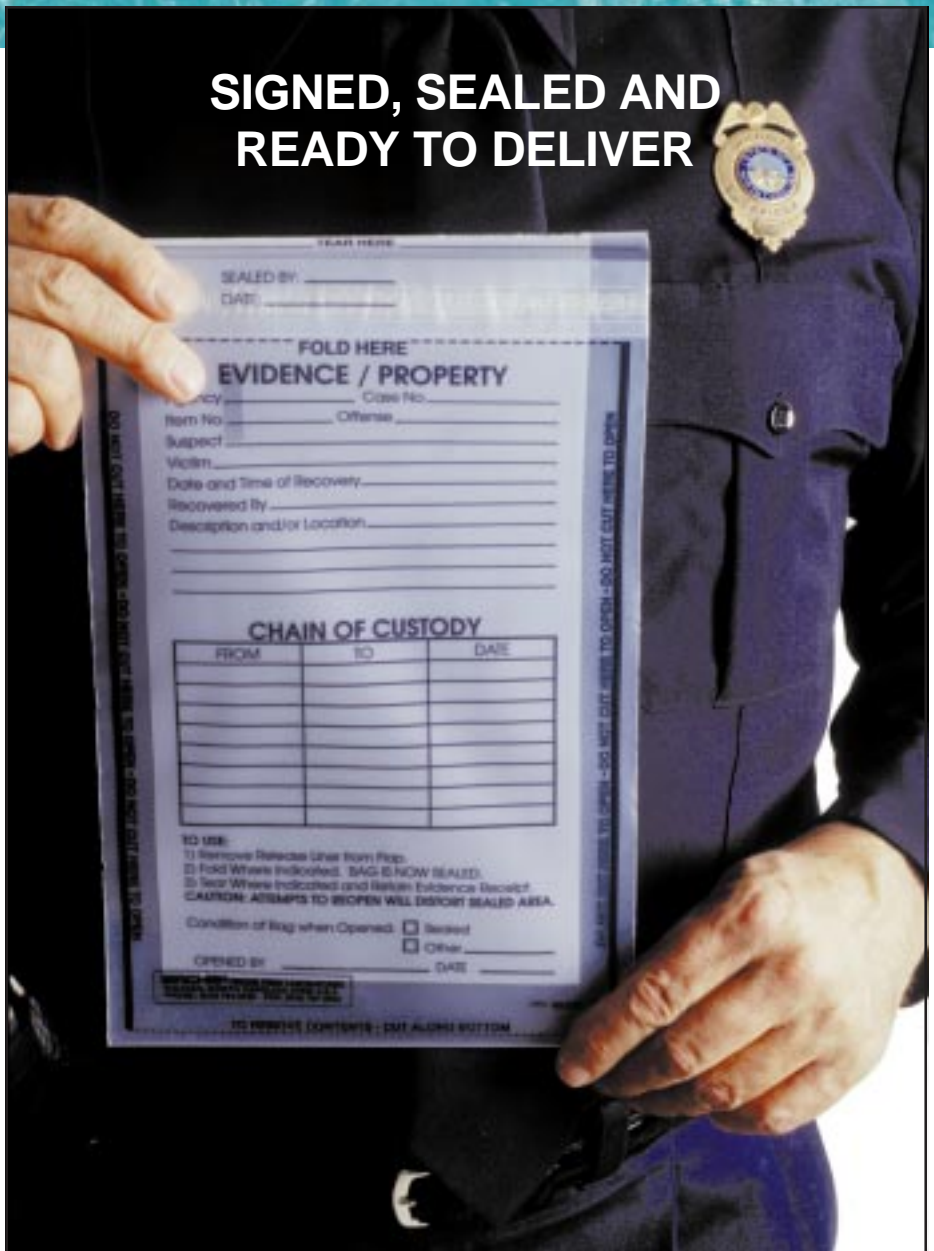

SEALS IN THREE EASY STEPS



Each package of 100, except No. IEB1550, includes a convenient storage/dispenser box.



1. Pull plastic backing away from adhesive.



2. Fold flap over the adhesive to seal.



3. Remove the information strip.

CATALOG NO.	DESCRIPTION	PRICE
IEB4000	4" x 7 1/2" INTEGRITY EVIDENCE BAG	\$22.75/100
IEB7500	7 1/2" x 10 1/2" INTEGRITY EVIDENCE BAG	\$29.40/100
IEB1200	12" x 15 1/2" INTEGRITY EVIDENCE BAG	\$47.60/100
IEB1550	5 1/2" x 15 1/2" INTEGRITY EVIDENCE BAG	\$38.50/100

EVIDENCE COLLECTION AND PROCESSING

LOCK UP A PRISONER'S PERSONAL PROPERTY
AS SECURELY AS YOU WOULD HIM ...

WITH **SIRCHIE**'S
PERSONAL PROPERTY
INVENTORY BAGS

FEATURES:

- SELF-SEALING
- HEAVY-DUTY
- WATER-RESISTANT
- TRANSPARENT
- TAMPERPROOF
- PUNCTURE-RESISTANT
- PRE-PRINTED INVENTORY LABEL

SIRCHIE's new personal property inventory bags are designed specifically for storing the personal property of those who are incarcerated.

The 9" x 12" bags feature a tamperproof seal to ensure the integrity of all belongings.

The seal creates a permanent lock which cannot be opened without destroying the bag. The bags are transparent for easily viewing the contents.

Plus, the bags are pre-printed with an inventory label—specially treated to provide a textured, paper-like quality—so that the contents may be listed right on the bag. Made of heavy-duty, 3.8-mil-thick, multi-layer, coextruded polyolefin film, the bags are lighter and stronger than paper and single-layer polyethylene films. The bags are tear- and puncture-resistant as well as water-resistant—additional safeguards against damage to the property during storage.

A perforated inventory tab attached to each bag will help keep track of the property. The tab may be removed easily and stored with the prisoner's file.

Available in quantities of 100, the personal property inventory bags are packaged in a convenient dispenser box for easy retrieval.

SEALS IN THREE STEPS!



Pull plastic backing away from adhesive.



Fold the flap over the adhesive seal.



Remove the perforated inventory tab.

CATALOG NO. IEB9000 PRICE: \$38.50/100

SEARCHBREATHE™ BREATHABLE EVIDENCE POUCHES

SIRCHIE®'s new **SEARCHBREATHE**™ breathable evidence pouch is made especially for storing evidence items that need breathing capability — but also need visibility. It is OK if the evidence is not dry. The pouch's breathing capability allows evidence to dry while safely stored inside. One side of the pouch is pre-printed in green ink with an evidence/property form and the other side is made of clear plastic. Pouches may be custom imprinted with your department's name in black ink (1000 bag minimum) and come prepackaged per 100.



FEATURES:

- Evidence/property form is pre-printed in green ink on one side
- Can be custom-imprinted in black ink with your department's name
- Specific area for attaching biohazard labels
- Pouch is breathable — allowing contents to reach ambient humidity
- Peel open without contaminating contents
- Withstands aging better than paper bags
- Plastics are non-leaching
- Pouch is a bacterial barrier when sealed
- Water resistant
- Available in two sizes: 8" x 12" and 10" x 15"
- Back is transparent — visually identify contents without opening the pouch



OR



EASY TO USE

1. Fill out form on front of pouch.
2. Attach biohazard label if needed.
3. Insert the evidence.
4. Seal with a heat sealer or fold over and seal with **SIRCHMARK**™ evidence tapes or integrity strips.
5. Open pouch by peeling apart at corner where it reads "open here."

CATALOG NO.	DESCRIPTION	PRICE
BEP812P	8" x 12" POUCH	\$68.95/100
BEP1015P	10" x 15" POUCH	\$90.95/100

SEARCH® FRAUDULENT CHECK BAGS

This is a heavy-duty polyethylene bag for easy filing. Seal with **SIRCHIE**®'s No. 616E heat sealer or with any of **SIRCHIE**®'s evidence tapes or labels. The bags are 3 1/2" x 8 1/2" x 0.005".

CATALOG NO. FCB50 PRICE: \$20.75/100



BULLET EVIDENCE BAG

These are 3 1/2" x 3" x 0.004" thick (89 mm x 76 mm 0.1 mm thick) clear polyethylene bags for storing shell casings or bullets. It is strongly recommend that recovered bullets be wrapped individually in tissue paper and sealed in separate bags.

CATALOG NO. BB3 PRICE: \$9.50/100



DISASTER BODY BAGS

These disaster body bags are super sturdy, 48" x 96" (1,219 mm x 2,438 mm) spun bonded Olefin Tyvek bags for temporary removal and storage of cadavers. They are a necessity at violent crime scenes, accidents and air disasters.

CATALOG NO. DBB200 PRICE: \$29.95/EACH



QUESTIONED DOCUMENT BAGS

Preserve anonymous letters, extortion letters and bank robbery notes in these full-sized questioned document bags. These polyethylene bags are 9" x 14" x 0.004" thick and provide the perfect vehicle for document transmittal to the lab. Be certain not to handle the documents with unprotected hands. Seal with the **SEARCH**® impulse evidence bag sealer or **SIRCHMARK**™ integrity tape.

CATALOG NO. BQD14 PRICE: \$38.50/100



GENERAL PURPOSE EVIDENCE BAGS

Package any number of non-organic evidential items in these handy-sized polyethylene bags. These sturdy 7 1/2" x 10 1/2" x 0.004" (190 mm x 267 mm x 0.1 mm) bags will accommodate a variety of shapes and sizes. **SIRCHIE**® offers a variety of sealing and integrity products to meet an agency's specific needs.

CATALOG NO. BH10 PRICE: \$26.50/100



**SEARCH® "CHECK EVIDENCE"
ZIP-TOP OR HEAT SEAL EVIDENCE BAGS**



These bags may be opened and closed at will with the patented zip-top seal or integrity protected with evidence labels or tape. Zip-top and heat seal bags are .004" (0.1 mm) thick polyethylene. Seal with **SIRCHIE®**'s No. 696E and 616E heat sealers.

CATALOG NO.	DESCRIPTION	PRICE
CEB100	ZIP-TOP 4" x 9" x 0.004"	\$43.95/100
CEB200	HEAT SEAL 4" x 9" x 0.004"	\$18.45/100

SEARCH® ZIP-TOP EVIDENCE BAGS

These heavy-duty, zip-top (self-sealing) evidence bags are produced from extra-durable 0.004" (0.10 mm) polyethylene. They are excellent for packaging non-organic items where the possibility of condensation is not a factor. Strong and durable—integrity can be ensured with evidence tape or labels after closure.

CATALOG NO.	DESCRIPTION	PRICE
ZTE01	4" x 6" x 0.004"	\$21.95/100
ZTE02	9" x 12" x 0.004"	\$34.50/100
ZTE03	13" x 18" x 0.004"	\$70.25/100



SEARCH® HEAT SEAL EVIDENCE BAGS

These bags are clear, extra-strong, economical evidence containers for securing a variety of non-organic evidential items. The bag's wall thickness is 0.003" (0.076 mm). Bags may be sealed instantly with a heat sealer, evidence labels or evidence tape.

CATALOG NO.	DESCRIPTION	PRICE
620E	3" x 5" x 0.003"	\$13.25/100
621E	4" x 9" x 0.003"	\$18.75/100
622E	8" x 12" x 0.003"	\$25.25/100
623E	12" x 20" x 0.003"	\$29.75/100
624E ...	15" x 9" x 3" x 0.003" (EXPANDABLE WIDTH)	\$31.95/100



SEARCH® IMPULSE EVIDENCE BAG SEALER

This is an excellent tool for crime scene search personnel. Integrity of evidence is assured with heat sealing of polyethylene bags. Just plug in and use—warm-up time is not required. Use it with any heat seal type evidence bag. The sealer features a time/temperature control, cast aluminum fabrication and 120-volt AC operation. The seal length is 12" (30 cm) and the weight: 11 lbs. (5 kg).

CATALOG NO. 696E PRICE: \$274.50

SEARCH® MINI-SEALER (120 VAC)

The **SEARCH®** mini-sealer provides an excellent tool for the investigator to seal evidence in plastic bags at the crime scene. A strong and lasting seal is facilitated. It operates on 120 VAC and features a rapid warm-up time and controlled heat dial. Use the mini sealer with any heat seal type evidence bag. The **SEARCH®** mini sealer measures 6" x 2 1/2" x 1 3/4" (152 mm x 64 mm x 44 mm).

CATALOG NO. 616E PRICE: \$87.95



EVIDENCE COLLECTION AND PROCESSING

EVIDENCE BAGS (KRAFT PAPER) AND PAPER ROLL



These brown Kraft evidence bags are pre-printed with all the necessary chain of possession and identification data. They are durable, breathable and available in three sizes for a variety of evidence packaging. Use **SIRCHIE**'s evidence integrity tapes to properly seal the bags. The Kraft paper roll is ideal for items that need packaging but are too large for bags.

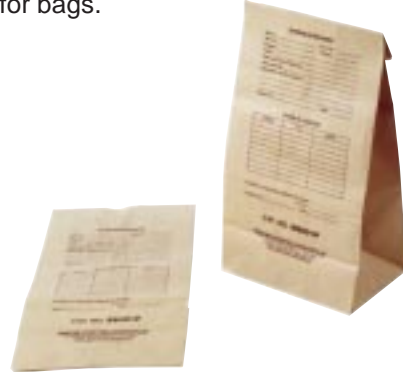

CATALOG NO.	DESCRIPTION	PRICE/QUANTITY
EB001P	EVIDENCE BAGS (7" x 4 1/2" x 13 3/4")	\$20.95/100
EB002P	EVIDENCE BAGS (8" x 5" x 18")	\$22.95/100
EB003P	EVIDENCE BAGS (12" x 7" x 18")	\$24.95/100
KRP100	KRAFT PAPER ROLL (36" x 1,500 FEET)	\$59.95

RUGGED MANILA EVIDENCE ENVELOPES

These are heavy-duty manila envelopes with a 3 1/2" (89 mm) expansion capability. Each envelope is printed with all the necessary evidence collection information to ensure proper chain of custody. These economical evidence envelopes are offered in two convenient sizes. Ensure integrity with **SIRCHMARK**™ tape or other integrity products.



CATALOG NO.	DESCRIPTION	PRICE/QUANTITY
EE513	5" x 11" x 3 1/2"	\$79.75/100
EE813	8" x 11" x 3 1/2"	\$87.50/100

TYVEK EVIDENCE COLLECTION ENVELOPES

These tyvek evidence collection envelope are tough! They're 9 1/2" x 12 1/2" (241 mm x 305 mm) evidence envelopes which defy the roughest handling and accommodate irregularly shaped and heavy items, such as weapons, tools and glass. They are printed in black and equipped with a contact-type adhesive. To further ensure integrity, use any of **SIRCHIE**'s **SIRCHMARK**™ integrity tapes.

CATALOG NO.	DESCRIPTION	PRICE/QUANTITY
TVK100	9 1/2" x 12"	\$86.95/100



EVIDENCE POUCHES WITH LINERS

These evidence poly pouches are airtight, transparent, heat-sealable and super strong. They have been saran-coated to provide air, vapor and liquid integrity. This helps to ensure that there will be no contamination of the evidence in the pouch.

CATALOG NO.	DESCRIPTION	PRICE/QUANTITY
EPP01	4" x 6"	\$12.95/100
EPP02	6" x 8"	\$13.50/75
EPP03	8" x 10"	\$23.50/75
EPP04	8" x 12"	\$18.00/40
EPP05	10" x 12"	\$23.50/50
EPP06	12" x 16"	\$22.50/25



WRITE-BLOCK EVIDENCE BAGS

These bags offer the same features as **SIRCHIE®**'s other evidence polyethylene bags, plus a write-block on the front of the bags. They're great for including additional warnings or instructions. Use pen or marker on the write block area.

CATALOG NO.	HEAT-SEAL WRITE-BLOCK BAGS	PRICE
PWB01	3" x 6" x .004"	\$12.95/100
PWB02	6" x 10" x .004"	\$17.95/100
PWB03	10" x 12" x .004"	\$23.95/100
PWB04	12" x 20" x .004"	\$28.95/100



CATALOG NO.	ZIP-TOP WRITE-BLOCK BAGS	PRICE
ZWB01	4" x 6" x .004"	\$20.95/100
ZWB02	9" x 12" x .004"	\$32.25/100
ZWB03	12" x 15" x .004"	\$65.25 /100

EVIDENCE BAG TUBING

It's impossible to have every size bag needed for every piece of evidence. **SIRCHIE®**'s polyethylene tubing allows agencies to custom-size just what is needed. Three different widths are available. Roll out the desired length of material, cut and use **SIRCHIE®**'s No. 696E or No. 616E heat sealer to seal the open ends.



CATALOG NO.	DESCRIPTION	PRICE
PET3	3" x 525' x .004"	\$19.95
PET6	6" x 525' x .004"	\$37.50
PET12	12" x 525' x .004"	\$55.95

EVIDENCE COLLECTION AND PROCESSING



EVIDENCE BOXES

Some types of evidence require storage other than plastic bags. Try **SIRCHIE®**'s evidence collection boxes. The boxes are made of 200-pound corrugated cardboard with a brown interior and white exterior. They provide for excellent storage on shelves in any storage room. On the bottom panel of these boxes are holes for securing evidence using **SIRCHIE®**'s No. ET100 evidence ties. Boxes are printed on the top—ready for evidence and chain of custody information.

CATALOG NO.	DESCRIPTION	PRICE
ECB001	MISCELLANEOUS EVIDENCE BOX, 14 3/4" x 7 7/8" x 2 1/4"	\$36.25/25
ECB001G	GUN EVIDENCE BOX, 14 3/4" x 7 7/8" x 2 1/4"	\$36.25/25
ECB001K	KNIFE BOX, 16" x 3" x 2"	\$29.95/25

Smaller evidence boxes provide excellent containers for the storage of metal, glass and other more fragile evidential items that do not want airtight protection.

CATALOG NO.	DESCRIPTION	PRICE
ECB002	EVIDENCE BOX, 2 1/2" x 1 7/8" x 7/8"	\$27.50/50
ECB003	EVIDENCE BOX, 4 1/2" x 3 1/2" x 1"	\$29.75/50

RIFLE EVIDENCE BOX

These evidence boxes are pre-printed with a place for recording the necessary chain of custody and identification information the outside of the box. They come with an adjustable spacer to hold shorter guns in place. Holes located in the bottom panel of the box are used to fasten the gun in place with **SIRCHIE®**'s No. ET100 releasable evidence ties. Boxes are 51 1/2" long, 9" wide and 3" deep.



CATALOG NO. ERB004	PRICE: \$53.95/25
--------------------	-------------------

RELEASABLE EVIDENCE TIES (NYLON)

These ties are perfect for holding evidence in place when using **SIRCHIE®**'s No. ECB001, No. ECB001G or No. ERB004 evidence boxes. The holes in the bottom panels of the boxes allow for the releasable ties to wrap around and secure the evidence in place. By pressing the releasing tab, these ties may be reused. Hook ties together for larger pieces of evidence.

CATALOG NO. ET100	PRICE: \$15.95/100
-------------------	--------------------

EVIDENCE SEALING AND IDENTIFICATION

EVIDENCE COLLECTION JARS

These are clear, airtight evidence jars for situations calling for rigid packaging. They are supplied with snug-fitting, screw-top caps—ideal for liquids and fragile types of evidence. Seal with integrity tape.

CATALOG NO.	DESCRIPTION	PRICE
ECJ1	1 FL. OZ. (30 ml)	\$6.95/15
ECJ2	2 FL. OZ. (59 ml)	\$8.95/15
ECJ4	4 FL. OZ. (118 ml)	\$9.95/15
ECJ8	8 FL. OZ. (237 ml)	\$12.75/15
ECJ16	16 FL. OZ. (473 ml)	\$22.95/15
ECJ2WM	2 FL. OZ. (59 ml)-WIDE MOUTH	\$11.50/15



EVIDENCE COLLECTION CONTAINERS

These containers are seamless, all-metal cans with an internal white label affixed to the top. They provide an excellent packaging medium for a wide variety of smaller, fragile evidential items. Protect bullets, shell casings, soil samples and other items.

CATALOG NO.	DESCRIPTION	PRICE
ECC5L	1/2 FL. OZ./1 1/2" DIA. x 1/2"	\$13.50/25
ECC1L	1 FL. OZ./2" DIA. x 5/8"	\$13.95/25
ECC2L	2 FL. OZ./2 3/8" DIA. x 3/4"	\$17.25/25
ECC4L	4 FL. OZ./3 1/8" DIA. x 15/16"	\$21.50/25



EVIDENCE COLLECTION TUBES

In today's society, exposure to AIDS (HIV), Hepatitis B and other blood-borne disease is a deadly serious problem. **SIRCHIE**'s clear plastic evidence collection tubes utilize an ethafoam stopper to immobilize the needle and protect evidence collection personnel. The tubes are 8" in length, 1 5/16" in outside dimensions and have a 0.030" wall thickness. Use **SIRCHIE**'s No. BIO400 biohazard strips (see page 193) to properly seal and mark tubes.

CATALOG NO. ECT1	PRICE: \$10.95/12
------------------------	-------------------

SYRINGE TRANSPORT TUBES

These tubes are well-marked with bright orange international biohazard markings. One end of the tube contains a sealing material that will immobilize the syringe and prevent needle leakage. Two labels are included inside the tube for evidence identification. The tube is 1" square, 8" in length and has a 0.032" wall thickness. The square construction allows for improved storage and handling. No more rolling around!

CATALOG NO. ECT2	PRICE: \$18.75/12
------------------------	-------------------



No. ECT1

No. ECT2

EVIDENCE COLLECTION TUBES (LARGE)



No. ECT3

This container is for holding various sizes of evidence, especially sharp objects such as knives and multiple syringes. Each tube has two end caps and an ethafoam insert for protecting sharp ends. Each tube is 3" in diameter, 12" in length and has a 0.035" wall thickness.

CAT. NO. ECT3	PRICE: \$16.50/8
---------------------	------------------

EVIDENCE SEALING AND IDENTIFICATION

QUESTION:

WILL "A" OR "B" GUARANTEE THE INTEGRITY OF YOUR EVIDENCE?



ANSWER: "A"

It is impossible to guard your evidence 24-hours a day for weeks, months or years—especially when it is in someone else's possession.

SIRCHMARK™ can!



In 1977, **SIRCHIE®** introduced **SIRCHMARK™** evidence tape as the best security tape available ... and it quickly became the most widely used integrity system by law enforcement agencies everywhere. It's still the best ... only today it's even better!

The **SIRCHMARK™** tape substrate used is now a mere 0.0015 of an inch in thickness and a new high-tack adhesive produces a superior seal on most surfaces. It is virtually impossible to remove the tape without destroying it. Once its seal has been put into place, **SIRCHMARK™** provides assurance—assurance that the integrity of crime scene evidence has been preserved until the moment it is presented in court.

SIRCHMARK™ is relied upon by some of the largest law enforcement agencies in the world. It is truly the evidence technician's best guarantee that a chain of possession will remain uncompromised.

SIRCHMARK™ TAPE DISPENSER

The new **SIRCHMARK™**, one-handed tape dispenser is a must-have for all criminal investigators! The TD100 features a creative new design which allows you to tear off a piece of evidence tape using only one hand. The dispenser's supply roll feeds the evidence tape to a serrated cutting edge, while a take-up roller winds the excess paper backing on a removable core. When the tape runs out, simply remove the core and dispose of the paper backing. The tape dispenser features three interchangeable cores which fit 1-inch, 2-inch or 3-inch tape rolls. Made of aluminum with a nickeloid and gray smoked Plexiglass cover, the TD100 is portable and can stand alone for field use, or it may be desk- or wall-mounted for office use.



DESIGNED FOR USE WITH **SIRCHMARK™** AND OTHER BRANDS OF EVIDENCE TAPE.

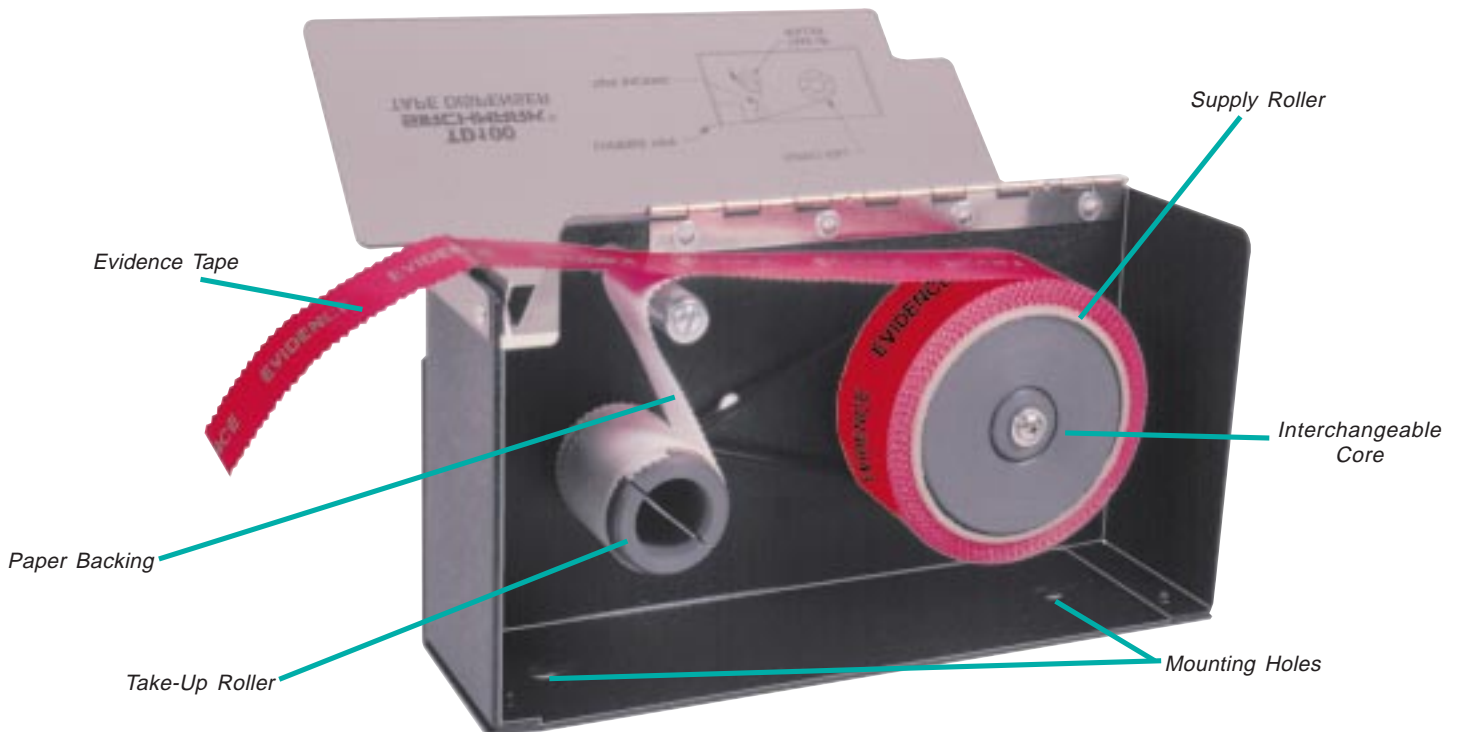

CATALOG NO. TD100 PRICE: \$48.95

EVIDENCE SEALING AND IDENTIFICATION

SIRCHMARK™ EVIDENCE TAPE

SIRCHMARK™ evidence tape is manufactured on a matte acetate base featuring a top surface which may be written on with a pencil or pen. It is coated with a permanent, quick-setting acrylic adhesive that defies removal from most surfaces. To increase the tape's ability to tear, it is perforated with 3/16" slits at 1/4" intervals. Dual-serrated tape edges add redundancy to the integrity. The tape's top surface is printed in translucent red or blue ink, then overprinted with an opaque black identifier or an agency's custom imprint. The roll width is 1 1/2" on a 3" core. The adhesive is permanent acrylic, high tack. The tape's thickness is 0.001" and the backing is Kraft liner, 50 lb. stock.

Attempts to remove **SIRCHMARK™** evidence tape will cause the tape substrate to break and peel off in irregular strips. The red or blue tint and black overprint will dissolve and smear when solvents like alcohol and acetone are applied—positive proof of tampering.

The tape's versatility makes it ideal for ensuring the integrity of all types of documents, liquid or dry specimens, sealed electronic equipment, custodial possessions, samples, even doors and windows. **SIRCHMARK™** is regularly used by hospitals and laboratories, banks and race tracks—wherever a tamperproof seal is needed! **Available in either red or blue with or without imprint, or with a customized logo or message imprinted on the tape. Custom colors are available upon request.**

CATALOG NO.	LENGTH	TAPE COLOR	IMPRINT	PRICE
SM1000	54 FT	RED	"EVIDENCE"	\$9.50
SM10002	108 FT	RED	"EVIDENCE"	\$13.95
SM2000	54 FT	RED	NONE	\$8.95
SM20002	108 FT	RED	NONE	\$13.95
SM2000B	54 FT	BLUE	NONE	\$8.95
SM2000B2	108 FT	BLUE	NONE	\$13.95
SM3000	54 FT	RED	CUSTOM*	\$12.25
SM30002	108 FT	RED	CUSTOM*	\$15.95
SM3000B	54 FT	BLUE	CUSTOM*	\$12.25
SM3000B2	108 FT	BLUE	CUSTOM*	\$15.95
SM4000	54 FT	TRANSPARENT	"EVIDENCE"	\$8.95
SM40002	108 FT	TRANSPARENT	"EVIDENCE"	\$13.95
SM4000B	54 FT	TRANSPARENT	CUSTOM*	\$11.00
SM4000B2	108 FT	TRANSPARENT	CUSTOM*	\$15.95
BIO300	108 FT	RED	"BIOHAZARD"	\$13.95

SIRCHMARK™ EVIDENCE TAPE WITH WHITE STRIPE

This tape has all the same excellent characteristics as **SIRCHIE®**'s other evidence tapes, but it features a 3/8" wide white strip throughout the entire length of the roll. The strip provides the space to write any necessary information. It readily accepts inks from ballpoint pens.

CATALOG NO.	LENGTH	TAPE COLOR	IMPRINT	PRICE
SM5000	54 FT	RED-WHITE STRIPE	"EVIDENCE"	\$9.50
SM50002	108 FT	RED-WHITE STRIPE	"EVIDENCE"	\$13.95
SM5000B	54 FT	BLUE-WHITE STRIPE	"EVIDENCE"	\$9.50
SM5000B2	108 FT	BLUE-WHITE STRIPE	"EVIDENCE"	\$13.95
SM6000	54 FT	RED-WHITE STRIPE	CUSTOM*	\$11.00
SM60002	108 FT	RED-WHITE STRIPE	CUSTOM*	\$15.95
SM6000B	54 FT	BLUE-WHITE STRIPE	CUSTOM*	\$11.00
SM6000B2	108 FT	BLUE-WHITE STRIPE	CUSTOM*	\$15.95

*Custom **SIRCHMARK™** EVIDENCE TAPE WITH agency imprint

This tape is available with an agency's name or division imprint. The minimum order for imprints is 24. Specify catalog number and imprint when ordering.



No. SM1000



No. SM2000



No. SM2000B



No. SM4000



No. SM5000B



No. SM6000



No. BIO300

EVIDENCE SEALING AND IDENTIFICATION

EVIDENCE INTEGRITY STRIPS

The evidence integrity strips are 1 3/8" (35 mm) wide x 7" (178 mm) long and allow agencies to distribute high-quality evidence tape selectively and economically. There is no need to pass out rolls of tape. Simply hand out as many strips as necessary. They feature the same destructible tape substrate as **SIRCHIE**® No. SM1000 with the added stability of a 0.0044" thick liner. Simply peel the evidence strip away from the liner and apply to the evidence. Six formats are available in eye-catching translucent red or blue with opaque black overprinting. Printable tape allows agencies to initial and date items as necessary. Strips are packaged in an easy-feed dispenser box which holds 100 strips.

CATALOG NO.	TAPE COLOR	IMPRINT	QUANTITY	PRICE
SM1000SR	RED	"EVIDENCE"	100/BOX	\$11.95
SM1000SB	BLUE	"EVIDENCE"	100/BOX	\$11.95
SM1000SLR	RED	"LAB SAMPLE"	100/BOX	\$11.95
SM1000SLV	BLUE	"LAB SAMPLE"	100/BOX	\$11.95
SM1000SCR	RED	"CONFIDENTIAL"	100/BOX	\$11.95
SM1000SCB	BLUE	"CONFIDENTIAL"	100/BOX	\$11.95
SM1000SSR	RED	"SECURITY SEAL"	100/BOX	\$11.95
SM1000SSB	BLUE	"SECURITY SEAL"	100/BOX	\$11.95
SM5000SER	RED	"SEALED EVIDENCE"	100/BOX	\$11.95
SM5000SEB	BLUE	"SEALED EVIDENCE"	100/BOX	\$11.95
BIO400	RED	"BIOHAZARD"	100/BOX	\$11.95

EVIDENCE INTEGRITY STRIPS WITH WHITE STRIPE

These strips feature a 3/8" wide white stripe with all the same fine qualities as the other **SIRCHIE**® integrity strips. The white stripe provides the space necessary to write any important information. The strips readily accept ink from ballpoint pens. They are packaged in quantities of 100 in an easy-feed dispenser box.

CATALOG NO.	TAPE COLOR	IMPRINT	QUANTITY	PRICE
SM1000SRW	RED-WHITE STRIPE	"EVIDENCE"	100/BOX	\$11.95
SM2000SRW	RED-WHITE STRIPE	CUSTOM*	100/BOX	\$18.00
SM1000SBW	BLUE-WHITE STRIPE	"EVIDENCE"	100/BOX	\$11.95
SM2000SW	BLUE-WHITE STRIPE	CUSTOM*	100/BOX	\$18.00

EVIDENCE IDENTIFICATION STRIPS

Identify evidence packages with these identification strips. These attention-getting red-on-white strips are tamper-resistant. It is offered in four formats for recording evidence collection information. The strips are 3/4" x 7" and offer convenience and economy. The strips are made of 0.0015" thick, top-printed matte acetate tape, with a 0.0044" thick liner. They are packaged in quantities of 100 in an easy-feed dispenser box.

CATALOG NO.	DESCRIPTION	QUANTITY	PRICE
603ES	EVIDENCE/ARTICLE	100/BOX	\$9.25
606ES	EVIDENCE/DATE—NUMBER	100/BOX	\$9.25
905ES	EVIDENCE/DO NOT TOUCH	100/BOX	\$9.25



SEARCH® EVIDENCE COLLECTION TAPES

No. 601ED

These pre-printed, pressure-sensitive tapes permit rapid identification of a variety of articles—with sufficient space for all required i.d. data. They are coated with water-resistant, durable adhesive and will adhere to almost any surface (including polyethylene) but are easily removed if necessary. Tapes are 1" wide, 500" long, and may be customized with an agency's imprint. Tape is available with or without a No. 145TW tape dispenser and is priced per roll.

SEARCH® PHOTO EVIDENCE RULE TAPE

This tape may be applied to glass metal, wood or virtually any surface, yet it is easily removed after photographs are taken. This tape also provides a ready means of permanently recording 1/16" increments, 12" repeat. The tape is printed in black on white.

CATALOG NO. 601ED TAPE W/DISPENSER PRICE: \$9.95
CATALOG NO. 601E TAPE ONLY PRICE: \$6.50
CATALOG NO. 602E TAPE ONLY WITH IMPRINT* PRICE: \$8.95

No. 603ED

SEARCH® EVIDENCE IDENTIFICATION TAPE

This tape is pressure-sensitive for marking evidential articles or sealing bags, cartons and other items. The tape features red lettering on a white background.

CATALOG NO. 603ED TAPE WITH DISPENSER PRICE: \$9.95
CATALOG NO. 603E TAPE ONLY PRICE: \$6.50
CATALOG NO. 604E TAPE ONLY WITH IMPRINT* PRICE: \$8.75

No. 606ED

SEARCH® EVIDENCE TAPE

This tape is for marking the outside of packages or boxes that contain evidence for transport or shipping. Red lettering is printed on a white background.

CATALOG NO. 606ED ... TAPE WITH DISPENSER PRICE: \$9.95
CATALOG NO. 606E TAPE ONLY PRICE: \$6.50
CATALOG NO. 607E ... TAPE ONLY WITH IMPRINT* PRICE: \$8.75

No. 803ED

SEARCH® EVIDENCE MARKING TAPE

Seal evidence packages with this distinctive evidence tape. "EVIDENCE" is printed in bold, black lettering on bright, attention-getting yellow tape. It sticks to virtually any surface.

CATALOG NO. 803ED TAPE WITH DISPENSER PRICE: \$9.95
CATALOG NO. 803E TAPE ONLY PRICE: \$6.50
CATALOG NO. 804E TAPE ONLY WITH IMPRINT* PRICE: \$8.75

No. 903ED

SEARCH® EVIDENCE PROCESS TAPE

This tape identifies evidence collected at the crime scene that will require specific processing such as latent prints and gunpowder residues. Red lettering is printed on white tape.

CATALOG NO. 903ED TAPE WITH DISPENSER PRICE: \$9.95
CATALOG NO. 903E TAPE ONLY PRICE: \$6.50
CATALOG NO. 904E TAPE ONLY WITH IMPRINT* PRICE: \$8.75

No. 905ED

SEARCH® FINGERPRINT EVIDENCE TAPE

This tape identifies latent print articles that have been processed and are ready for photography. Investigators' "initial" squares are part of the format. Red lettering is printed on white tape.

CATALOG NO. 905ED TAPE WITH DISPENSER PRICE: \$9.95
CATALOG NO. 905E TAPE ONLY PRICE: \$6.50
CATALOG NO. 906E TAPE ONLY WITH IMPRINT* PRICE: \$8.75

*DEPARTMENT IMPRINT—MINIMUM ORDER=24 ROLLS

SIRCHSEAL™ EVIDENCE IDENTIFICATION LABELS WITH DISPENSER CARTON

Having trouble keeping track of evidence labels? Try **SIRCHSEAL™**, a series of labels printed on rolls and supplied in convenient dispenser cartons. The unique dispenser carton keeps labels clean and ready to use instantly. Just pull the paper tab and a fresh label pops out. All **SIRCHSEAL™** labels are manufactured with permanent adhesive to ensure the integrity of all forms of physical evidence. Ideal for use on polyethylene bags, glass, paper, wood and metal.

SIRCHSEAL™ IDENTIFICATION LABEL

This is a standard format “evidence” label with red lettering printed on white tape.
 Label size: 1 1/2" x 3" (38 mm x 76 mm)
 Quantity/roll: 100 each with dispenser box

CATALOG NO. EIL01R..... PRICE: \$11.75



No. EIL01R

SIRCHSEAL™ POLICE SEAL LABEL

This “police” seal label attracts immediate attention with its black printing and red background.
 Label size: 1 1/2" x 3" (38 mm x 76 mm)
 Quantity/roll: 100 each with dispenser box

CATALOG NO. EIL02R..... PRICE: \$12.75



No. EIL02R

SIRCHSEAL™ EVIDENCE SEAL LABEL

These labels feature standard format “evidence labels” with red lettering printed on white tape.
 Label size: 1 1/2" x 3" (38 mm x 76 mm)
 Quantity/roll: 100 each with dispenser box

CATALOG NO. EIL03R..... PRICE: \$11.75



No. EIL03R

SIRCHSEAL™ INTEGRITY SEAL LABEL

These labels feature standard format “integrity seal” with red lettering printed on white tape.
 Label size: 1 1/2" x 3" (38 mm x 76 mm)
 Quantity/roll: 100 each with dispenser box

CATALOG NO. EIL04R..... PRICE: \$11.75



No. EIL04R

SIRCHMARK™ EVIDENCE INTEGRITY SEALS

Ensure evidence integrity at economical prices. These 1 1/2" x 2" evidence seals are another outstanding type of **SIRCHMARK™** integrity tape—in a reduced format. It is virtually impossible to remove the 0.0015" thick tape substrate without destroying it. The seals are ideal for rape kits and small evidential items and containers. The seals are available in translucent red or blue, with black printing in rolls of 100 and 500.

CATALOG NO.	DESCRIPTION	PRICE
ESR1	RED/ROLL OF 100 LABELS	\$5.95
ESR5	RED/ROLL OF 500 LABELS	\$9.95
ESB1	BLUE/ROLL OF 100 LABELS	\$5.95
ESB5	BLUE/ROLL OF 500 LABELS	\$9.95



No. ESR1



No. ESB1

EVIDENCE IDENTIFICATION

COMBINATION CRIME SCENE REPORT/ CHAIN OF POSSESSION LABELS

Printed on tough, tamper-proof stock, this label defies removal from any surface. There is ample space for all pertinent collection and identification data, and a separate section for "chain of possession." Printed in red and black, the labels feature an easily removed protective backing. Just fold the label along the center score and remove the backing stock. The labels are a must for marking individual articles, packages and containers. The labels are 3 1/2" x 4 1/2".

- CATALOG NO. ZTE10 PRICE: \$21.95/100**
- CATALOG NO. ZTE10M PRICE: \$82.50/1,000**

COMBINATION EVIDENCE LABEL AND TAG

Record all the basic collection and identification data on this label, which is packaged with a 60-lb. liner. The No. ZTE10T offers the same adhesion qualities as the No. ZTE10 label, but serves as a rigid tag. A hole at the top of the tag is for tying to evidence. The label size is 5" x 3 1/2".

- CATALOG NO. ZTE10T PRICE: \$26.50/100**
- CATALOG NO. ZTE10TM PRICE: \$219.50/1,000**

COMBINATION EVIDENCE/CHAIN OF POSSESSION TAGS

These large, 6 1/4" x 3 1/8" pre-printed evidence identification tags feature a uniform format for evidence description on one side and three possession chaining on the other. Tags are printed on 200-pound tag stock with reinforced eyelets for attachment with string or wire.

- CATALOG NO. ET3 PRICE: \$21.95/100**
- CATALOG NO. ET3M PRICE: \$164.95/1,000**



EVIDENCE TAGS

These are pre-printed tough, manila evidence tags which feature reinforced eyelets for attachment to evidence with either string or wire ties. The tag size is 3 1/2" x 1 7/8" .

- CATALOG NO. 608E PRICE: \$16.50/100**
- CATALOG NO. 608EM PRICE: \$109.50/1,000**

BLANK EVIDENCE TAGS

These tough manila tags are blank, pre-printed with "evidence." They feature reinforced eyelets for attachment to evidence with supplied wire ties. Tags are 3 3/4" x 1 7/8".

- CATALOG NO. 608E1 PRICE: \$13.25/100**
- CATALOG NO. 608E1M PRICE: \$99.50/1,000**



BOX SEALING EVIDENCE TAPE AND DISPENSER

Seal packages, especially large ones, instantly with this 3" box sealing tape. The word "evidence" is printed in bold. A rugged, hand-held dispenser ensures years of trouble-free use.

CATALOG NO.	DESCRIPTION	PRICE
704E	3" x 165' EVIDENCE SEALING TAPE	\$22.00
BSET1D	3" TAPE DISPENSER	\$40.75

COMBINATION EVIDENCE/CHAIN OF POSSESSION LABEL

These labels are the perfect choice for the permanent marking of evidence. They are printed on tough, tamperproof stock—defying removal from about any surface. They are a must for marking individual articles as well as packages and containers. Dimensions: 4" x 5".

CATALOG NO. ET6 PRICE: \$29.75/100

EVIDENCE CONTROL LABELS

Affix the main label to the evidence and remove the lower portion that acts as an evidence receipt. Control labels are supplied in rolls of 100 and are perforated for easy removal. They are pre-printed in blue on white coated-label stock. Dimensions: 6" x 4 1/2".

CATALOG NO. EIL05R PRICE: \$20.50/ROLL

EVIDENCE "POLICE SEAL" LABEL

These labels are printed in black on bright red fluorescent stock. They are 1 1/2" x 3", pre-cut to size and are the best deterrent to the intentional or accidental opening of evidence containers. The label's permanent adhesive adheres to almost any surface.

CATALOG NO. EIL02 PRICE: \$10.95/100

CATALOG NO. EIL02M PRICE: \$59.50/1,000



No. EIL02

EVIDENCE BAG SEALS

Seal paper or plastic evidence bags with these permanent adhesive labels. Fill out data, peel off backing and fold where indicated over evidence bag. Dimensions: 3 1/2" x 2".

CATALOG NO. ES3 PRICE: \$10.00/100

No. ES3

EVIDENCE IDENTIFICATION LABEL

These labels are 2 3/4" x 1 3/4" and feature a pre-scored backing for easy removal. Labels have a permanent, pressure-sensitive adhesive. Red lettering is printed on white label.

CATALOG NO. EIL01 PRICE: \$10.50/100

CATALOG NO. EIL01M PRICE: \$59.50/1,000

No. EIL01

VOID EVIDENCE SEALS

Use these seals on smooth surfaces such as plastic. The word "void" appears through the label once it has been tampered with. Use it on paper, such as envelopes, bags, boxes and it cannot be removed without tearing the container.

Dimensions: 2" x 1 5/8"

CATALOG NO. VES01 PRICE: \$19.95/100



BEFORE



AFTER

EVIDENCE MARKING AND COLLECTION TOOLS

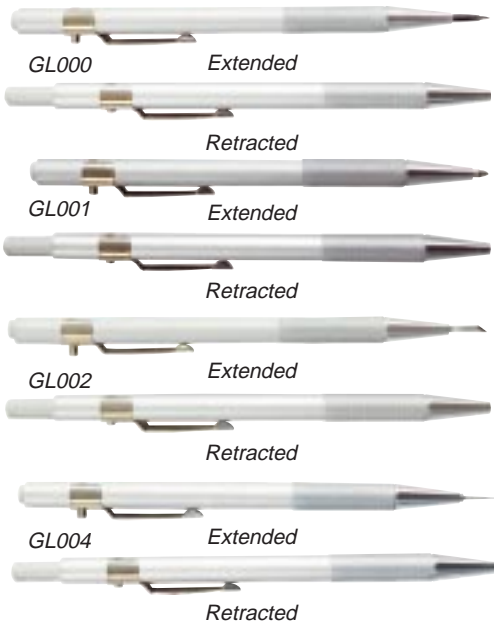

This is the Krime Kit, and it is supplied with a vinyl shirt-pocket protector and No. GL000, No. GL001, No. GL002 and No. GL004 evidence marking tools.

UNIQUE TOOLS FOR EVIDENCE

These are identification tools for the field investigator and laboratory technician—a unique selection. For convenience and assistance in gathering and identifying physical evidence, these timesaving, labor-saving tools are a necessary part of the evidence collection and identification mission.

CATALOG NO.	DESCRIPTION	PRICE
GL000	CARBIDE TIP SCRIBER	\$13.25
GL011	REPLACEMENT CARBIDE TIP	\$7.75
GL001	DIAMOND TIP SCRIBER	\$18.25
GL010	REPLACEMENT DIAMOND TIP	\$11.50
GL002	EVIDENCE COLLECTION KNIFE	\$12.25
GL012	REPLACEMENT BLADE, 5/16"	\$3.95
GL004	RIDGE COUNTER	\$13.75
GL0051	REPLACEMENT POINTS	\$4.50
KK100	KRIME KIT (WITH GL000, GL001, GL002, GL004)	\$49.95

MECHANICAL EVIDENCE MARKER

This marker writes easily on glass, polyethylene, metal, wood and paper. It is supplied with a pocket clip and four extra black refills.



CATALOG NO. 611E PRICE: \$4.95

EVIDENCE SCRAPE AND SCRIBER

This tool is excellent for scribing identification marks or scraping/retrieving evidence, such as paint samples. It is 6 3/4" long and made of hardened tool steel.



CATALOG NO. KCP141 PRICE: \$6.99

CHINA MARKER

This marker is for marking glass, plastic, metal, wood and paper. It is available in black or white for high contrast.



CATALOG NO. KCP144 .. BLACK ... PRICE: \$2.95
 CATALOG NO. KCP145 .. WHITE ... PRICE: \$2.95

PERMANENT INK EVIDENCE MARKER

This is a permanent ink marker for evidence labeling. It writes on anything—permanently! Available in black or red ink.



CATALOG NO. EMR1 RED PRICE: \$3.25
 CATALOG NO. EMB1 BLACK PRICE: \$3.25

PERSONAL PROTECTION

SIRCHIE® takes the preservation of health seriously and offers a complete line of high-quality, cost-effective, anti cross-contamination packs, kits, anti-viral soaps, towelettes and disinfectant cleaners. These are tailored for use in situations where a person now is required by OSHA to protect himself/herself from the increasing risk of blood-borne or saliva-borne disease.



Contents Removed

PERSONAL PROTECTION KIT

This is a complete personal kit meeting/exceeding OSHA guidelines and has full FDA 510(K) authorization where applicable.

Kits consist of:

- 1-Full Length Impervious Open-Back Gown
- 1-Disposable Latex Glove Pair
- 1-Mask with Splash Visor
- 1-Anti-Microbial Wipe
- 1-Biohazard Waste Bag



CATALOG NO. PPP100L	KIT W/L GOWN	PRICE: \$12.95
CATALOG NO. PPP100XL	KIT W/XL GOWN	PRICE: \$13.95
CATALOG NO. PPP100XXL.....	KIT W/XXL GOWN	PRICE: \$14.95

BIOHAZARD CLEANUP KIT

This complete biohazard cleanup kit meets/exceeds OSHA guidelines and has full FDA 510(K) authorization where applicable.

No. PPP200 consists of:

- 1-Pair High-Risk Powder-Free Latex Gloves
- 1-Body Fluid Treatment/Encapsulant (BTE)
- 1-Pair Disposable Waste Scoops
- 1-Surface Disinfectant Wipe
- 1-Antimicrobial Wipe
- 1-Packet Purell Instant Hand Sanitizer
- 1-Biohazard Waste Bag



Contents Removed

CATALOG NO. PPP300	PRICE: \$13.75
--------------------------	----------------

BIOHAZARD LABELS

These labels feature the universal biohazard symbol printed on permanent label material.

CATALOG NO.	DESCRIPTION	PRICE
BIO100	1 1/2" x 1 1/2" RED ON WHITE	\$10.95/100
BIO200	4" x 5" BLACK ON FLUORESCENT RED	\$20.00/100



WHITE COTTON GLOVES

These white cotton gloves offer the comfort and protection needed when gathering evidence. They are available in three sizes.

CATALOG NO. G001	MEDIUM	PRICE: \$9.25/DOZEN PAIR
CATALOG NO. G002.....	LARGE	PRICE: \$9.60/DOZEN PAIR
CATALOG NO. G003.....	X-LARGE	PRICE: \$14.50/DOZEN PAIR

PERSONAL PROTECTION



No. SF0072



No. SF0073



No. SF0074

DISPOSABLE JUMPSUIT WITH HOOD

One size fits all. This jumpsuit is made of strong tyvek fabric—resistant to snags, tears, punctures and many chemicals. It is roomy, lightweight and comfortable.

CATALOG NO. SF0072 PRICE: \$9.75

DISPOSABLE SHOE COVERS

One size fits all. These tyvek shoe covers keep shoes clean and protected.

CATALOG NO. SF0073 PRICE: \$2.50/PAIR

DISPOSABLE ANTI-ODOR MASK

This respirator may be used in situations to guard against nuisance-level organic vapors and in other situations where dust/mist protection is needed.

CATALOG NO. SF0074 PRICE: \$5.75



No. SF0076



No. SF0077



No. SF0079



No. SF0080



No. SF0078

LATEX GLOVES

These are durable, natural, ambidextrous latex gloves, available in powdered and powder-free in three different thicknesses for added degrees of protection. All gloves are large.

CATALOG NO.	DESCRIPTION	DIMENSIONS	PRICE
SF0076	LATEX POWDER-FREE	10" x .005"	\$11.95/100
SF0077	LATEX, POWDERED	10" x .005"	\$11.95/100
SF0079	LATEX, POWDERED, BLUE	12" x .010"	\$18.25/50
SF0080	LATEX, POWDER-FREE	12" x .014"	\$26.95/50

NITRILE GLOVES

These thin, comfortable, soft nitrile gloves provide extra puncture- and abrasion-resistance. They're lightly powdered, large and ambidextrous.

CATALOG NO. SF0078 NITRILE POWDERED, .004" THICKNESS PRICE: \$39.50/100

PROTECTIVE CLOTHING OUTFIT NO. 1

- No. SPC0100 consists of:**
- 6- No. SF0072 Disposable Jumpsuits
 - 6- No. SF0073 Disposable Shoe Cover Pairs
 - 6- No. SF0074 Disposable Anti-Odor Masks
 - 6- No. SF00771 Latex Glove Pairs, Large Ambidextrous
 - 1- No. SPC01001 Carrying Case, Molded Copolymer



CATALOG NO. SPC100 PRICE: \$94.50

PROTECTIVE CLOTHING OUTFIT NO. 2

- No. SPC0200 consists of:**
- 6- No. SF0073 Disposable Shoe Cover Pairs
 - 6- No. SF0072 Disposable Jumpsuits
 - 1- No. PU005 Anti-Putrefaction Mask
 - 2- No. PU006 Replacement Mask Filters
 - 6- No. SF00771 Latex Glove Pairs, Large Ambidextrous
 - 1- No. SPC02001 Carrying Case, Molded Copolymer



CATALOG NO. SPC200 PRICE: \$132.75

ANTI-PUTREFACTION MASK (FOR PERSONAL PROTECTION)

FOR WET ... OR DRY FLOATERS

Filtration is supplied by a chemically treated filter that has been NIOSH/MSHA approved for organic vapors, chlorine, hydrogen chloride, chlorine dioxide and sulfur dioxide.

The mask is perfect for use in conjunction with any of the **SIRCHIE**® postmortem kits—an absolute must during hot summer months!

The **SIRCHIE**® anti-putrefaction mask kits were designed to eliminate the overwhelming odor from a body undergoing putrefaction. Now an investigator may go about his or her job of investigation, fingerprinting and photographing—no matter what the state of decomposition.

These low maintenance, reusable masks weight less than 1/2 lb. and are made to fit any head size. Only one mask per person is recommended to eliminate the diseases spread by sharing face pieces.

The easy-to-use sliding suspension system makes them comfortable to wear. All masks are NIOSH/MSHA approved.

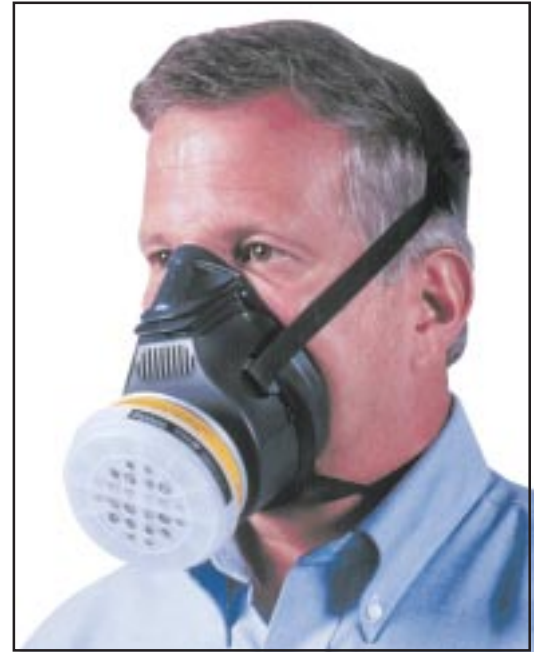

No. PU001 single mask kit consists of:

- 1- No. PU005 Anti-Putrefaction Mask
 - 2- No. PU006 Replacement Mask Filters
 - 1- No. SF00771 Disposable Latex Glove Pair
 - 12- No. FPT2541 Cleaner Towelettes
 - 1- No. TI3102 Instruction/Time Log Booklet
 - 1- No. PU0011 Molded Copolymer Carrying Case, 12 1/8" x 7 1/4" x 5 1/2" with Plastic Inserts
- Weight: 2 1/2 lbs.

CATALOG NO.	DESCRIPTION	PRICE
PU001	COMPLETE	\$99.00
PU002A.....	REPLACEMENT FILTER	\$18.00



No. PU003 double mask kit consists of:

- 2- No. PU005 Anti-Putrefaction Masks with Filters
 - 4- No. PU006 Replacement Mask Filters
 - 2- No. SF00771 Disposable Latex Glove Pairs
 - 24- No. FPT2541 Cleaner Towelettes
 - 1- No. TI3102 Instruction/Time Log Booklet
 - 1- No. PU0011 Molded Copolymer Carrying Case, 16 3/8" x 8 5/8" x 7" with Plastic Inserts
- Weight: 4 1/2 lbs.

CATALOG NO.	DESCRIPTION	PRICE
PU003	COMPLETE	\$199.00
PU002A.....	REPLACEMENT FILTER	\$18.00

PERSONAL PROTECTION

HALF MASK PARTICULATE RESPIRATOR

The SF0034 provides breathing protection against dust, mists and fumes that are common in many forensic applications. When fitted with a P100 (high-efficiency) filter, this mask offers exceptional protection against particulate and airborne pathogens (e.g. TB and most bacteria). The mask can also be fitted with a R95 (for dust and mist applications) filter. The mask is lightweight and reusable. Excellent for crime scene processing.



Mask with HEPA filter.

CATALOG NUMBER	DESCRIPTION	PRICE
SF0034H	HALF MASK WITH 5 P100 FILTERS	\$26.50
SF0034D	HALF MASK WITH 5 R95 FILTERS	\$23.00
SF0034HR	REPLACEMENT P100 FILTERS, PACK OF 25	\$45.00
SF0034DR	REPLACEMENT R95 FILTERS, PACK OF 25	\$22.75

MULTI-PURPOSE HALF MASK REGULATOR

Designed for applications that do not require full face protection. The mask combines a latex-free silicone seal with a formed plastic shell outer body. The soft silicone conforms to the shape of every nose. The combination of soft silicone and hard plastic ensures a comfortable, leak-resistant fit to a typically hard-to-fit area. The unit is both compact and lightweight. It is excellent for use at the crime scene where decaying matter and hazardous vapors may be present.

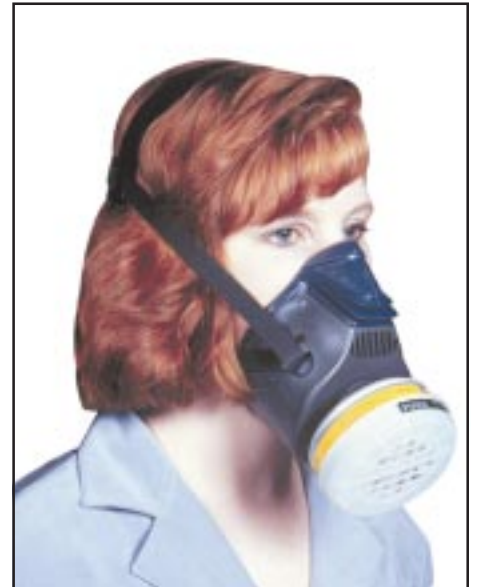

CATALOG NUMBER	DESCRIPTION	PRICE
PU005	MASK ONLY	\$25.00
PU006	FILTER, ORGANIC VAPOR/ACID GAS	\$18.00
PU007	FILTER, P100	\$11.00
PU008	FILTER, ORGANIC VAPOR/P100	\$22.00

OTHER FILTERS AVAILABLE

PANORAMA NOVA

Panorama Nova full facepiece uses one size fits all technology to offer excellent fit for a wide range of facial types and sizes. Easy to replace polycarbonate lens provides wide field of vision. Nosecup is always included. Single cartridge system keeps cartridges out of line of vision. Each mask has a stainless steel speech diaphragm for excellent communication without amplification. Accepts all Dräger NIOSH approved cartridges, Dräger NBC canister and NATO NBC canisters. Mask is shown with Dräger Phosphine canister which also offers protection against tear gas (CS, CN). Canister sold separately.



CATALOG NO. SFL1000 PANORAMA NOVA PRICE: \$164.00

KARETA M

The KARETA M offers full protection against warfare gases. Drinking tube is included as standard feature. This one size mask has two safety-glass eyepieces to provide excellent vision. The 40 mm thread connector accepts wide range of NIOSH approved cartridges, Dräger NBC canisters and NATO NBC canisters. Mask is shown with Dräger NBC canister. Canister sold separately.



CATALOG NO. SFL2000 KARETA M MASK PRICE: \$175.00

PHOSPHINE CANISTER AND NBC CANISTER

The phosphine canister is NIOSH approved for use against phosphine and particulate environments. Carries 42CFR for approval as a P100 particulate filter. Also offers protection for (though not approved by NIOSH to) tear gas (CS and CN). The NBC canister is appropriate protection against nerve agents, blood agents, biological hazards, tear gas and a wide range of other hazardous chemicals. Does not carry NIOSH approval. The filters are used for the multi-purpose half mask on page 201A. They also can be used with the Panorama series or Kareta M gas mask.



CATALOG NO. SFL001 PHOSPHINE CANISTER PRICE: \$27.00

CATALOG NO. SFL002 NBC CANISTER PRICE: \$32.00

PARAT C

PARAT C is a lightweight, portable easy-to-don smoke escape hood designed for self rescue in the event of a fire. Protects the wearer for 15 minutes from smoke, carbon monoxide and toxic gases normally present during a fire. PARAT C is one of the few smoke masks sold in the U.S. that carry the prestigious European Smoke Hood approval (EN403). It fits virtually everyone, including those who wear glasses or have beards. Wearer can breathe and speak normally. Lifesaving communications will not be missed. Five-year shelf life with no maintenance required.



CATALOG NO. SFL3000 PARAT C PRICE: \$150.00

MICROPARTICLE EVIDENCE COLLECTION

In every crime scene, it is vitally important for the investigator to realize that while the gross physical evidence must receive full attention, it often will be absent. Microparticle evidence is present in most cases and is therefore of much wider availability. If there is a single important lesson to be learned by the investigator, it is the extent to which he/she may rely on microparticle physical evidence if he/she is willing to make full use of it.

A knife, gun, signature or burglar tool are immediately recognized as constituting physical evidence. Less often is it considered that dust, microscopic fragments of all types, bacteria, even an odor, equally may be physical evidence, and quite often the most important of all.

It is, for example, well established that the most useful types of physical evidence are generally microscopic in dimensions, that is, not noticeable to the naked eye, and therefore most likely to be overlooked by both the criminal and the investigator. For this reason, the microscopic evidence persists at the scene of a crime long after all the visible and obvious evidence has been removed. Evidence vacuum sweepers provide a means of processing large areas in a short amount of time.



EVIDENCE VACUUM SWEEPER FILTER ATTACHMENT

A vacuum sweeper with a special filter attachment is one of the most important evidence collection tools available to the crime scene investigator. The **SIRCHIE**® No. 617E filter assembly was designed to give optimum performance during the search for microparticle evidence. Constructed of clear, methacrylate plastic in two pieces joined by precision-machined, thread joint, the filter boasts a metal filter support screen which permits unobstructed suction. Tapered aluminum connections permit attachment to any tank and cyclone-type sweepers. The dimensions of the attachment are: 5 3/4" long, 4 1/2" diameter.

CATALOG NO. 617E PRICE: \$59.95

P.E.M. POLYESTER MONOFILAMENT MICROFILTERS

These filters are designed for use with the No. 617E filter attachment. Suction through the filter is increased many times over conventional filter papers due to the precision-woven, lint-free, polyester monofilament fabric. Debris is collected uniformly across the P.E.M. surface and not in the center as

with paper filters. Valuable microscopic evidence collects on the surface and tests have proven that five times more debris is collected than with standard filter paper.

CATALOG NO. PEM01 PACKAGE OF 100 FILTERS PRICE: \$39.95

EVIDENCE VACUUM SWEEPER KIT

This is a complete kit for microparticle evidence collection. The kit includes a 120VAC vacuum, a microparticle filter attachment, microfilters, vacuum extension tubes, crevice and floor tubes and a vacuum hose, as well as vials and bags for evidence collection, as well as identification tape. From the crime scene to the laboratory—in one carrying case.

No. 618E1 consists of:

- 1- No. 618E101 Vacuum Cleaner, 6-amp Motor, 120VAC with the following:
 - 3-No. 618E1011 Vacuum Bags
 - 1-No. 618E1012 Flexible Plastic Hose
 - 2-No. 618E1013 Extension Tubes, 20" long
 - 1-No. 618E1014 Wall and Floor Tube
 - 1-No. 618E1015 Crevice Tool
- 1- No. 617E Evidence Filter Assembly
- 50- No. PEM011 Monofilament Microfilters
- 5- No. KCP149 Evidence Collection Vials with Caps, 3" x 1 1/4"
- 1- No. KCP224 Inner Storage Case with:
 - 10- No. IEB4001 Integrity Evidence Bags, 4" x 7 1/2"
 - 5- No. IEB75001 Integrity Evidence Bags, 7 1/2" x 10 1/2"
- 1- No. 603E Evidence Identification Tape
- 1- No. 618E11 Leatherette-Covered Carrying Case with Molded Inserts
Dimensions: 24" x 16 1/2" x 10"
Weight: 23 lbs.



CATALOG NO. 618E1 PRICE: \$325.95

EVIDENCE COLLECTION IDENTIFICATION AND SEALING KIT

This popular kit has been designed to accommodate the new, fully portable, rechargeable evidence vacuum sweeper. The most often required tools and materials to process a crime scene for physical evidence are included in this general purpose, professional crime scene investigation kit.

No. 627E100 consists of:

- 1-No. 618RE101 Rechargeable Vacuum Sweeper and Recharging Unit
- 1-No. 762UV Longwave Ultraviolet Light Source, 6 VDC
- 1-No. 318M Magnifier, 2X, 3.5" dia.
- 1-No. PL1000 Flashlight, Clear Acrylic, D-Cell
- 2-No. KCP235 D-Cell Batteries, Alkaline
- 1-No. KCP114 Retractable Measuring Tape, 6'
- 1-No. SK800 Precision Steel Tape Measure, 50ft/15m, English/metric
- 1-No. KCP110 Scissors, 5"
- 4-No. ECL1001 Evidence Collection Lifter with Backing Sheet, 6" x 15"
- 4-No. KCP149 Polystyrene Vials, 2 oz. with Screw Cap, 1 1/4" dia. x 3"
- 4-No. KCP150 Amber Plastic Vials, 7 dram with Snap-On Cap
- 1-No. 603E Evidence Identification Tape, 1" x 500"
- 1-No. G0021 Pair of Cotton Gloves
- 4-No. KCP230 AA-Cell Batteries, Alkaline

Blood Collection Module

- 2- No. KCP122 Blood Collection Tubes, 7 ml with EDTA
- 1- No. KCP137 Syringe with Needle, Disposable, 10 cc
- 1- No. KCP138 Scalpel, Disposable, 5"
- 2- No. KCP151 Vials, Amber Plastic, 5 dram with Snap-On Cap
- 1- No. KCP152 Carrying Case, Molded Polypropylene, 8 1/3" x 4 1/2" x 1 3/4"

Physiological Collection Module

- 8- No. KCP153 Vials, 4 ml with 17 x 35mm Cap
- 2- No. KCP154 Pipettes, with Suction Bulb
- 4- No. 288DP Pipettes, Disposable, with Capillary and 3 ml. Bulb
- 1- No. KCP152 Carrying Case, Molded Polypropylene, 8 3/8" x 4 1/2" x 1 3/4"

Collection Probe Module

- 1- No. KCP155 Spatula, Steel Blade, 7"
- 1- No. GL002 Retractable Lifter Knife with Blade
- 1- No. KCP156 Spatula, Stainless Combination Blade Micro, 7 1/2"
- 2- No. KCP141 Prober with Blade, Chrome Steel, 6"
- 2- No. KCP139 Tweezers, Plastic, 4 3/4"
- 1- No. KCP152 Carrying Case, Molded Polypropylene, 8 1/3" x 4 1/2" x 1 3/4"



Identification Marking Module

- 1- No. KCP145 China Marker, White
- 1- No. 611E Mechanical Evidence Marker, Black with 4 Refills
- 2- No. KCP147 White Chalk
- 1- No. KCP157 Black, Felt-Tip Marker
- 1- No. FC350 Non-Retractable Ridge Counter
- 1- No. GL000 Carbide Tip Scriber
- 1- No. KCP152 Carrying Case, Molded Polypropylene, 8 1/3" x 4 1/2" x 1 3/4"

Miscellaneous Materials

- 20- No. EIL011 Evidence Identification Labels, "Crime Evidence"
- 10- No. EIL021 Evidence Labels
- 10- No. 608E01 Evidence Tags with Ties
- 10- No. 608E11 Evidence Tags with Ties
- 10- No. 618REF Disposable Filters
- 5- No. ZTE101 Chain of Possession Labels
- 2- No. 606E Rolls of Evidence Tape
- 2- No. KCP224 Texturized Polypropylene Accessory Case
- 2- No. 627E1001 Carrying Case, Vinyl Leatherette-Covered with Machined-Foam Inserts
Dimensions: 24" x 16 1/2" x 10"
Weight: 23 lbs.

CATALOG NO. 627E100 PRICE: \$439.95

**THE FIRST VACUUM DESIGNED SPECIFICALLY FOR EVIDENCE COLLECTION
(NOT A MODIFIED PHOTOCOPY MACHINE MAINTENANCE VACUUM)**

- Single use filter assembly
- Particle retention of 0.1 micron
- Hermetically sealed filter assembly



**THE VACUUM UNIT—
NO. 619E**

- diameter: approx. 4 3/4"
- length: approx. 8"
- weight: 3.8 lbs
- power: 120vac
- motor: 4.5 amps
- function: front impeller, rear exhaust

This is a vacuum unit dedicated to one function—collecting trace evidence at the crime scene. Venturi-controlled suction for surface vacuuming and hermetically sealed, single use filter assembly eliminate cross contamination from individual crime scenes. The entire sealed filter assembly in its evidence bag is submitted to the crime laboratory for examination.

The No. 619E is equipped with a manually controlled venturi to restrict suction to top surface vacuuming only when required.

THE DISPOSABLE FILTER UNIT—NO. 619E1 (ONE-TIME USE ONLY)

- Description: Single-use filter with 0.1 micron particle retention, featuring a clear window and sealed with evidence tape to ensure integrity
- Overall Length: 14"
- Chamber Diameter: 3"



The No. 619E1 filter assembly is ready for use.



The No. 619E1 filter assembly is pictured hermetically sealed.

CATALOG NO.	DESCRIPTION	PRICE
619E	VACUUM W/ POWER CORD AND 7' EXTENSION HOSE	\$257.50
619E1	FILTER ASSEMBLY, HERMETICALLY SEALED	\$9.96



MICRO EVIDENCE COLLECTION KIT

No. 619EK Micro Evidence Collection kit consists of:

- 1-No. 619E Evidence Vacuum Sweeper
 - 2-No. 619E1 Filter Assemblies
 - 1-No. 619EK2 Extension Hose, 7'
 - 1-No. 619EK3 AC Power Cord, Detachable, 10'
 - 1-No. 619EK100 Carrying Case
- Dimensions: 18 3/4" x 14 1/4" x 6"
Weight: 12.7 lbs.

CATALOG NO. 619EK PRICE: \$396.00

RECHARGEABLE EVIDENCE VACUUM SWEEPER

This is a fully portable evidence vacuum sweeper for micro-particle evidence collection. It is a compact, light-weight unit, equipped with rechargeable batteries—permitting use in the most remote or difficult-to-reach crime scenes. Hermetically sealed filter assemblies ensure against contamination.

- Rechargeable battery power
- Hermetic, single-use filter assembly
- Particle retention of 0.1 micron

Use: Primarily in confined areas such as vehicles or wherever commercial power is not available.



No. 618REK consists of:

- 1-No. 618RE Rechargeable Vacuum
 - 1-No. 618REC 110V AC Recharge Unit
 - 2-No. 618REF Filter Assemblies, Hermetically Sealed
 - 1-No. 618RE1 Molded Copolymer Carrying Case with Machined Foam Inserts
- Dimensions: 19" x 11 1/2" x 10 1/2"
Weight: 7 1/2 lbs.



CATALOG NO. 618REK COMPLETE KIT PRICE: \$136.00
CATALOG NO. 618REF FILTER ASSEMBLY, HERMETICALLY SEALED PRICE: \$9.95

EVIDENCE COLLECTION LIFTERS

The problem of obtaining evidence at a crime scene is a difficult one, especially securing microscopic particles. The use of evidence collection lifters helps to solve this problem. This unique lifting device may be used throughout the scene to collect evidence such as dust and dirt particles, fibers, hairs and stains. Simply remove the backing material and press the lifter against the area under scrutiny, lift, then apply to an opaque vinyl cover. Dimensions: Lifter: 6" x 15" x .005". Vinyl White Backer: 6" x 15" x .010".



CATALOG NO. ECL100 LIFTERS AND BACKERS/PACKAGE OF 12 PRICE: \$19.95

REPULPABLE EVIDENCE TAPE



Hair and fiber evidence are often the only link between a crime and its perpetrator—and they're all too often overlooked. Repulpable evidence tape from Sirchie offers a solution. Apply the tape to those areas of suspicion, remove and immerse in water or methanol (check with the crime lab—often, it requests the tape itself). The hair or fiber evidence separates from the adhesive backer and is then recovered after filtering. The tape is 3" (76 mm) wide x 180' (54.9 m) long.

CATALOG NO. RET001 PRICE: \$49.95

EVIDENCE COLLECTION KITS

EVIDENCE COLLECTION AND IDENTIFICATION KIT

This is an excellent kit for crime scene search officers. Contents permit preliminary search with longwave ultraviolet light for locating evidence such as fibers and stains. The kit includes all the necessary gear for collecting, marking and preserving all types of physical evidence. Instructions and procedures booklet included.



No. MEC100 consists of:

- 1- No. SK800 50ft/15m Steel Tape Measure
- 1- No. PL1000 2-Cell Flashlight
- 2- No. 603E Rolls of Evidence Tape
- 2- No. 606E Rolls of Evidence Tape
- 12- No. EIL011 Evidence Labels
- 12- No. 608E01 Evidence Tags with Ties
- 12- No. 608E11 Evidence Tags with Ties
- 10- No. ZTE101 Chain of Possession Labels
- 20- No. ZTE011 Zip-Top Bags, 4" x 6" x 0.004"
- 10- No. ZTE021 Zip-Top Bags, 9" x 12" x 0.004"
- 1- No. CUV100T Ultraviolet Light with Batteries
- 4- No. ECL1001 Evidence Collection Lifters
- 2- No. KCP139 4 3/4" Plastic Tweezers
- 4- No. KCP230 AA-Cell Batteries, Alkaline
- 2- No. KCP235 D-Cell Batteries, Alkaline

- 1- No. KCP110 Pair of Scissors
 - 1- No. GL000 Carbide-Tipped Scriber
 - 1- No. GL002 Evidence Knife
 - 1- No. KCP144 China Marker, Black
 - 1- No. KCP145 China Marker, White
 - 4- No. KCP146 Liquid Sampling Pipettes, 1 ml
 - 1- No. 318M 3 1/2" Magnifying Glass
 - 1- No. KCP141 Probe with Paint Chip Cutter
 - 3- No. KCP147 Sticks of White Chalk
 - 2- No. KCP122 Collection Tubes with EDTA, 7 ml
 - 2- No. KCP148 Disposable Syringes, 3 cc
 - 3- No. KCP149 Plastic Jars with Caps, 2 fl. oz.
 - 3- No. KCP150 Amber Plastic Jars with Caps, 7 fl. dram
 - 3- No. KCP151 Amber Plastic Jars with Caps, 5, fl. dram
 - 2- No. SF00771 Disposable Latex Glove Pairs
 - 1- No. KCP140 Stainless Steel Spatula
 - 1- No. KCP138 Disposable Scalpel
 - 1- No. KCP114 Steel Tape Measure, 6'
 - 1- No. KCP152 Molded Polypropylene Inner Storage Case, 8 3/8" x 4 1/2" x 1 11/16"
 - 1- No. MEC1001 Attache-Type, Molded Polypropylene Carrying Case with Metal Frame and Machined Internal Component Pad, 18" x 13 1/4" x 5 3/84"
- Weight: 10.8 lbs.

CATALOG NO. MEC100 PRICE: \$219.95

EVIDENCE SEALING AND IDENTIFICATION KIT

This is a complete kit for preserving and identifying collected evidence at the scene of a crime. This kit offers a variety of evidence marking materials for identifying glass, metal, cloth and wood. It is an excellent addition for field and lab work.

No. ES1750 consists of:

- 1- No. 616E Evidence Bag Sealer, 120V AC
- 1- No. GL000 Retractable Carbide Tipped Scriber
- 1- No. GL002 Retractable Evidence Knife
- 1- No. KCP110 Pair of Scissors
- 1- No. KCP144 China Marker, Black
- 1- No. KCP145 China Marker, White
- 1- No. KCP157 Felt Tip Marker, Black
- 1- No. 603 Evidence Tape
- 20- No. EIL021 Evidence Labels
- 10- No. 608E01 Evidence Tags with Ties
- 10- No. 608E11 Evidence Tags with Ties
- 30- No. 620E1 Evidence Bags, 3" x 5" x 0.003"
- 30- No. 621E1, Evidence Bags, 4" x 9" x 0.003"
- 30- No. 622E1, Evidence Bags, 8" x 12" x 0.003"



- 10- No. ZTE101 Chain of Possession Labels
 - 1- No. KCP224 Molded Polypropylene Storage Container, 10 3/8" x 4 5/8" x 1 11/16"
 - 1- No. ES17501 Molded Copolymer Carrying Case with Molded Plastic Inserts, 16 3/8" x 8 5/8" x 7"
- Weight: 6.4 lbs.

CATALOG NO. ES1750 PRICE: \$189.00

SEARCH® ROLL-UP EVIDENCE COLLECTION KIT

This kit is perfect for the crime scene. The case rolls out, offering a complete layout of all the kit components—without any searching. It is a self-contained kit which allows the investigator to complete many tasks—from securing the crime scene to handling, containing, marking and integrity-sealing the evidence.

No. RCK100 consists of:

- 1- No. BT1001 Barrier Tape, Crime Scene, 250'
- 1- No. SM1000 **SIRCHMARK™** Evidence Tape, Red
- 1- No. SK900 Tape Measure, 100ft/50m
- 1- No. 318 3 1/2" Magnifier
- 10- No. ZTE101 Crime Scene Labels
- 10- No. ET31 Evidence/Chain of Possession Tags
- 2- No. ECJ11 Evidence Collection Jars, 1 oz.
- 2- No. ECJ21 Evidence Collection Jars, 2 oz.
- 2- No. ECJ41 Evidence Collection Jars, 4 oz.
- 2- No. ECCL11 Evidence Collection Cans, 1 oz.
- 2- No. ECCL21 Evidence Collection Cans, 2 oz.
- 2- No. ECCL41 Evidence Collection Cans, 4 oz.
- 10- No. IEB75001 Integrity Bags, 7 1/2" x 10 1/2"
- 10- No. IEB40001 Integrity Bags, 4" x 7 1/2"
- 1- No. 903ES Evidence ID Strips, 100
- 10- No. 608E11 Evidence Tags
- 1- No. KCP138 Disposable Scalpel
- 10- No. EIL021 Evidence ID Labels
- 10- No. EIL011 Evidence ID Labels
- 10- No. ZTE011 Zip-Top Evidence Bags, 4" x 6"
- 1- No. KCP110 Pair of Scissors
- 1- No. KCP139 Plastic Tweezers
- 1- No. EMB1 Black Evidence Marker

- 1- No. EMR1 Red Evidence Marker
- 1- No. KCP144 China Marker, Black
- 1- No. KCP145 China Marker, White
- 1- No. KCP141 Probe with Paint Chip Cutter
- 1- No. 603E Evidence Tape
- 1- No. G0021 Cotton Gloves, Pair, Large
- 1- No. SF00771 Disposable Vinyl Glove Pair
- 2- No. ECT21 Syringe Collection Tube
- 1- No. SM1000SR Integrity Strips, Red, 100
- 1- No. KCP115 Penlight, 2 AA, 1.5-Volt
- 2- No. KCP231 AA Batteries, Carbon
- 10- No. ZTE021 Zip-Top Evidence Bags, 9" x 12"
- 1- No. RCK1001 High-Impact, Polystyrene Carrying Case, Dimensions: 10 3/4" x 9 1/2" x 11 1/2" Weight: 11 lbs.



CATALOG NO. RCK100 PRICE: \$152.95

EVIDENCE COLLECTION KIT

This kit offers a complete assortment of special, heavy-duty (4 mil) poly bags, labels, tags and bag seals. It is packaged in a molded copolymer case that puts evidence collection materials right where they're needed—in the squad card and at the crime scene.

No. ECK consists of:

- 1-No. BH10 Evidence Bags, 7 1/2" x 10 1/2" x .004", 100
- 1-No. BQD14 Questioned Document Bags, 9" x 14" x .004", 100
- 1-No. CEB100 Zip-Top Check Evidence Bags, 4" x 9" x .004", 100
- 1-No. ES3 Evidence Bag Seals, 100
- 1-No. ET3 Evidence/Chain of Possession Tags, 100
- 1-No. K06 Premise Seals, 100
- 1-No. ET6 Evidence Labels, 100
- 1-No. HT6 Hand Protector Labels, 100
- 1-No. DBB200 Body Bag, 36" x 91" x 0.004"

- 1-No. BRS60 Shotgun Bags, 6" x 60" x 0.004", 10
- 1-No. BB3, Bullet Bags, 3 1/2" x 3" x 0.004"
- 1-No. GW48 Investigation Notebook
- 1-No. ECK11 Molded Copolymer Carrying Case with Molded Plastic Inserts, 17 1/2" x 10 1/4" x 8 1/2" Weight: 13 3/4 lbs.



CATALOG NO. ECK1 PRICE: \$99.95

EVIDENCE COLLECTION AND PROCESSING



SEARCH® METAL DETECTION SWEEPER

Search with the no-nonsense detector: It offers performance features that every investigator can count on—such as automatic VLF-ground rejection, automatic tuning, variable trash rejection, a headphone jack, a built-in speaker and a deep-seeking, lightweight, 8" search coil. Best of all, this metal detector ignores ground minerals and trash as it detects evidential targets. The No. MD605B is a sophisticated instrument, yet simple enough to operate. Double-derivative electronics provide up to 25 hours of silent, no-threshold, no-drift operation on a single 9-volt battery. The detection sweeper dimensions are: 41" x 8 1/4" x 8 1/2". Weight: 2.66 lbs. Carrying case dimensions: 48" x 11" x 5". Weight: 11.5 lbs.

Leading Particulars

- Automatic, turn-on-and-go operation
- Silent, no-threshold operation
- VLF-slow motion discrimination
- Full-range discrimination control
- Stereo/mono headphone jack
- Patented double-derivative electronics
- Shielded (electro-static insulated) 8" search coil
- Only 2.66 pounds
- Cushioned arm rest and flexon grip
- Only one 9-volt transistor battery
- Simple, one-knob operation

CATALOG NO. MD650B METAL DETECTION SWEEPER ... PRICE: \$297.00
CATALOG NO. MD650A CARRYING CASE PRICE: \$89.50

PERMANENT-TYPE RECOVERY MAGNET

This is the ideal tool for conducting a search for ferrous materials discarded in lakes, rivers and streams. Two to three hundred pounds of pulling power will dredge up large and small items. Dimensions: 13 3/4" x 2 3/4" x 2 3/4". Weight: 16 1/2 lbs.

Leading Particulars

Pull: 200-300 Pounds with Total Magnet Control
Balance: Dual Eye Loop, 1" Diameter



CATALOG NO. HRM100 ... MAGNET WITH 100 FEET OF POLYPROPYLENE ROPE .. PRICE: \$185.95
CATALOG NO. HRM200 CARRYING CASE FOR MAGNET AND ROPE PRICE: \$52.50

DEBRIS SIFTING SHOVEL

This time and labor-saving innovation is a modified coal shovel featuring precision-machined sorting holes that isolate objects greater than 3/8" (1 cm) diameter, while allowing water run off. Sifting through ashes is important because an investigator may find evidence, such as furniture hardware—even when areas have been completely burned. In addition, the absence of some remains may lead to the motive. For these reasons, it is necessary to sift through debris to collect representative samples of solid materials such as wood, ashes, wiring, melted metal or glass.



CATALOG NO. DSS21 PRICE: \$149.95

ARSON EVIDENCE COLLECTION



“SOLID” MATERIAL EVIDENCE COLLECTION CONTAINERS

These containers offer a unique method of preserving “solid” forms of physical evidence. Solids are collected and placed in cans. Once the lid is put in place, an airtight seal is formed preventing flammables and hydrocarbons from evaporating into the atmosphere. When the containers are delivered to the lab, they are heated and air samples are drawn off through the rubber septum contained in the lid.

CATALOG NO.	DESCRIPTION	PRICE
AEC00	1-PINT	\$22.50/10 CANS
AEC01	1-QUART	\$31.50/10 CANS
AEC02	1-GALLON	\$51.25/10 CANS



DEBRIS SIFTING SCREENS

Sifting screens eliminate large volumes of unimportant evidence prior to packaging for transmission to the crime laboratory. Sifting screens presort physical evidence to size, while allowing small, insignificant particles to remain at the scene. Top-quality, durable construction provides years of service. Frames are fashioned from heavy-gauge, tubular steel and screen mesh is galvanized steel. These screens are supplied with each order: one—15 1/2" x 15 1/2" frame with 1/8" mesh, one—17 5/8" x 17 5/8" frame with 3/8" mesh and one—20" x 20" frame with 7/16" mesh.

CATALOG NO. DBS3 PRICE: \$137.50

CHAR DEPTH GAUGE

The depth of charring of wood is one indicator as to how long the substance burned, how intense the fire was and may indicate the possibility that accelerants were used when charring is exceptionally deep in isolated areas. The gauge permits rapid, accurate measurement throughout the fire scene and often eliminates having to cut out timbers unnecessarily. It is calibrated in 1/64" increments and measures up to 1" of char depth. It is a necessary aid to any arson investigation kit.

CATALOG NO. CG1000 PRICE: \$19.95



ARSON INVESTIGATION LIQUID SAMPLER KIT

This kit will assist the investigator in collecting arson scene liquid with as little contamination as possible. Each non-leachable glass sample bottle is equipped with a hydrocarbon-resistant cap. Filtering equipment is provided to separate debris from suspected liquids in order to minimize site contamination and facilitate subsequent laboratory analysis. The instruction booklet, “Arson Investigator’s Manual” is included.

No. AEC200 consists of:

- 2- No. AEC105 Vacuum Samplers, 280cc with Mailing Labels
- 1- No. AEC201 Tubing, Teflon, 10'
- 1- No. AEC202 Cutter, Tubing, 5"
- 2- No. AEC203 Glass Jars with Polypropylene Nozecone Cap, 2 fl. oz.
- 6- No. AEC206 Filters and Closures

- 2- No. AEC204 Hypodermic Needles, 20 ga., Stainless Steel, 4"
 - 6- No. AEC205 Test Tubes, Polypropylene, High-Pressure and Vacuum Filtration
 - 2- No. AEC207 Glass Jars, with Polypropylene Nozecone Cap, 1 fl. oz.
 - 25- No. AEC208 Strips, Oil-Based Test Paper
 - 25- No. AEC209 Strips, Ph Paper, Acid/Base, Litmus
 - 6- No. KCP137 Syringe with Needle, Disposable, 10 cc
 - 4- No. SM1000SR1 Evidence Integrity Strips
 - 10- No. EIL011 Evidence Identification Labels
 - 1- No. AEC2001 Leatherette-Covered Carrying Case with Machined Plastic Inserts, 15 1/2" x 12" x 5 1/2"
- Weight: 7 3/4 lbs.

CATALOG NO. AEC200 PRICE: \$275.00

ARSON INVESTIGATION SOLID SAMPLER KIT

This kit is designed specifically for the collection of materials at fire and arson scenes. The tools provided facilitate the removal of the most commonly required evidential samples, including plaster, soot excelsior, wood chips and soil samples. The supplied collection containers allow for quick and easy, contaminant-free delivery to the lab for analysis. The "Arson Investigator's Manual" is included.

No. AEC300 consists of:

- 1- No. 316M Magnifier, 2.5X, 2 1/2" dia.
- 1- No. 606E Evidence Tape, 1" x 500"
- 1- No. AEC011 Solid Materials Evidence Collection Container, 1 quart
- 1- No. AEC021 Solid Materials Evidence Collection Container, 1 gallon
- 2- No. AEC203 Glass Jars with Polypropylene Nozecone Cap, 2 fl. oz.
- 6- No. AEC205 Test Tubes, Polypropylene, High-Pressure and Vacuum Filtration
- 6- No. AEC206 Filters and Closures
- 1- No. KCP110 Pair of Scissors, 5"
- 1-No. KCP155 Spatula, Steel Blade, 7"
- 1- No. KCP142 Spoon, 12"
- 2- No. AEC207 Glass Jars with Polypropylene Nozecone Cap, 1 fl. oz.
- 1- No. KCP138 Scalpel, Disposable, 5"

- 18- No. EIL011 Evidence Identification Labels, "Crime Evidence"
 - 1- No. KCP139 Tweezers, Plastic, 4 3/4"
 - 2- No. KCP137 10 cc Syringes with Needles, Disposable
 - 1- No. KCP140 Spatula, Stainless, Micro
 - 1- No. KCP141 Prober with Blade, Chrome Steel, 6"
 - 6- No. ZTE011 Zip-Top Evidence Bags, 4" x 6" x 4 mil
 - 6- No. ZTE021 Zip-Top Evidence Bags, 9" x 12" x 4 mil
 - 6- No. ZTE031 Zip-Top Evidence Bags, 13" x 18" x 4 mil
 - 1- No. KCP224 Case, Molded Polypropylene, 10 3/8" x 4 5/8" x 1 11/6"
 - 1- No. AEC3001 Carrying Case, Vinyl Leatherette-Covered with Steel Hardware and Machined Plastic Inserts, 18 1/4" x 11 3/4" x 7 3/4"
- Weight: 12.1 lbs.



CATALOG NO. AEC300 PRICE: \$245.00

ARSON SCENE TOOL KIT

Particularized for arson investigation, this complete tool kit provides essential support at every crime scene. Power and/or manual drilling, cutting and chiseling tools allow for the extrication of even the most difficult to obtain evidence. Conveniently packaged in a heavy-duty metal box, this tool kit facilitates comprehensive criminal investigation. Protective gloves and disposable clothing also are included.



No. AEC400 consists of:

- 1-No. AEC401 Heavy-Duty Sledge-Type Mallet
- 1-No. AEC402 9" Tong
- 1-No. AEC403 Hammerhead and Hatchet
- 1-No. AEC404 Collapsible Folding Steel Shovel
- 1-No. AEC405 Heavy-Duty Rubber Glove Pair
- 1-No. AEC406 Pair of Safety Goggles
- 3-No. SF0072 Disposable Jumpsuits
- 1-No. AEC407 5" Wire Cutter Pliers

- 1-No. AEC408 8" Scraper/Putty Knife
 - 1-No. AEC409 11" Screwdriver
 - 1-No. AEC410 7" Screwdriver
 - 1-No. AEC411 8" Phillips Screwdriver
 - 1-No. AEC412 Claw Hammer
 - 1-No. AEC422 Blade Trowel
 - 1-No. AEC414 1/4" Electric Drill
 - 1-No. AEC415 5/16" Masonry Drill Bit
 - 1-No. AEC416 3/8" Masonry Drill Bit
 - 1-No. AEC417 1/2" Masonry Drill Bit
 - 1-No. AEC418 1/2" Drill
 - 1-No. AEC419 1" Heavy-Duty Masonry Chisel
 - 1-No. AEC420 1 1/4" Wood Chisel
 - 1-No. AEC421 6" Regular Pliers
 - 1-No. AEC413 All-Purpose Hack Saw, 8 Blade Positions
 - 1-No. AEC400C Carrying case, Metal, Tool Box-Type, Dimensions: 18 3/8" x 10 1/4" x 9 3/8"
- Weight: 34 lbs.

CATALOG NO. AEC400 PRICE: \$438.00

**ARSON EVIDENCE COLLECTION WITH
the **SEARCH®** HYDROCARBON DETECTOR**



PARTIAL LIST OF DETECTABLE CONTAMINANTS:

- Gasoline Vapor • Acetone Vapor • Benzene Vapor • Hydrogen • Alcohol (various)
- Ethane • Isobutane • Methane • Hexane • Propane

The No. CGD100 will detect the most minute concentrations of combustible hydrocarbons present at suspected arson and fire scenes. This lightweight and fully portable instrument will locate quickly the source(s) of hydrocarbon emissions with pinpoint accuracy. Simple and easy-to-use, this unit is also a very effective tool for checking for gasoline storage tanks. The NO. CGD100 comes in handy for many unforeseeable and unexpected situations and no investigative department is fully equipped without one. A highly visible, 10-segment bar graph instantly displays comparative vapor concentrations. The hydrocarbon-sensing head is located at the end of a 12" gooseneck-style extension arm, allowing the No. CGD100 to be used in crevices and other hard-to-reach locations. This extension arm quickly folds into the case for efficient storage and transport.



An operator removes the **SEARCH®** hydrocarbon detector's flexible probe from its nest.

Unit is complete with:
Rechargeable nickel cadmium batteries,
battery charger and belt holster.

Leading Particulars

- Audible Signal
- Adjustable Sensitivity
- Quick Warm-up (45-60 Seconds)
- Long, Flexible Probe
- Replaceable Components
- Low Voltage Indicator
- Cordless
- Durable Construction
- Rechargeable Batteries

No. CGD100

Electrical Specifications:

Internal Batteries:

Quantity and Type: 4 2/3 C nickel cadmium cells

Charging Current: 75 milliamperes nominal

Capacity: 750 milliamperere hours

Voltage: 4.8 volts nominal

Time to Full Charge: Typically 10-14 hours

Sensing Element: Internally heated TGS semiconductor type

Audio Frequency Range: Typically 2-500 cps.

Back View



Front View



Visual Display: 10 element red-diffused LED

Mechanical Specifications:

Weight:

No. CGD100 only: 1 lb., 6 oz.

No. CGD100, case and charge: 2 lbs., 1 oz.

Dimensions:

8 1/2" L x 3 1/4" W x 3" H

Construction: Molded, high-impact ABS with polished nickeloid steel trim

CATALOG NO. CGD100 PRICE: \$395.00

CIVIL DEFENSE SET

The civil defense set utilizes colorimetric Dräger detector tubes, the same tube chemistry used by NATO for many years in single-tube detectors. The kit provides two CDS sets for detection of eight chemical substances, including nerve, blood, lung, nose and throat irritating agents. And the complete CDS kit is much less expensive than the typical \$15,000 to \$20,000 cost of spectroscopic devices.



Leading Particulars

- Low cost compared to spectroscopic devices
- No power supply required for manual pump
- On-the-spot results in five minutes
- No warm-up time
- No calibration
- Minimal training
- Simple operation
- No filters to replace

CDS I AGENT	DRÄGER TUBE	SENSITIVITY
Hydrocyanic Acid	Hydrocyanic Acid	1 ppm
Phosgene	Phosgene	0.2 ppm
Lewisite	Organic Arsenic Compounds and Arsine	3 mg/m ³ (org. arsenic) 0.1 ppm (arsine)
N-Mustard	Organic Basic Nitrogen Compounds	1 mg/m ³
S-Mustard	Thioether	1 mg/m

CDS V AGENT	DRÄGER TUBE	SENSITIVITY
Nerve Agents	Phosphoric Acid Esters	0.025 ppm
Phosgene	Phosgene	0.2 ppm
Cyanogen Chloride	Cyanogen Chloride	0.25 ppm
Chlorine	Chlorine	0.2 ppm
S-Mustard	Thioether	1 mg/m

CATALOG NO. CDS100 CIVIL DEFENSE SET PRICE: \$2,900.00

PAC III

This is an intelligent, versatile, single gas portable instrument for over 45 toxic gases and oxygen that features interchangeable, long-life DrägerSensors, user adjustable alarm settings, and a plain language menu for easy calibration. This rugged, field-proven instrument is available in basic, standard and hygiene versions, allowing the user to match their needs with the appropriate solution. However, all Pac III's feature an illuminated display, the loudest and brightest alarms available, and a number of battery options, With an extensive portfolio of accessories to complement any measurement task, the PAC III is the smart choice.

DrägerSensors XS	Measuring Range	Part Number	Price
Amines	0-100 ppm	PAC3001	\$395.00
Ammonia	0-300 ppm	PAC3002	\$395.00
Carbon Monoxide*	0-2000 ppm	PAC3003	\$335.00
Carbon Dioxide	0-5 Volume %	PAC3004	\$395.00
Chlorine	0-20 ppm	PAC3005	\$395.00
Hydrides	0-20 ppm	PAC3006	\$395.00
Hydrogen	0-200 ppm	PAC3007	\$395.00
Hydrogen Peroxide	0-20 ppm	PAC3008	\$395.00
Hydrogen Cyanide	0-50 ppm	PAC3009	\$395.00
Hydrogen Sulfide	0-100 ppm	PAC3010	\$335.00
Hydrogen Sulfide 500	0-500 ppm	PAC3011	\$350.00
Mercaptans	0-100 mg/m ³	PAC3012	\$425.00
Nitrogen Dioxide	0-50 ppm	PAC3013	\$350.00
Nitric Oxide	0-100 ppm	PAC3014	\$350.00
Organic Vapors	0-200 ppm	PAC3015	\$395.00
Organic Vapors-A	0-200 ppm	PAC3016	\$395.00
Oxygen	0-25 Volume %	PAC3017	\$235.00
Phosphine 500	0-500 ppm	PAC3018	\$425.00
Sulfur Dioxide	0-100 ppm	PAC3019	\$350.00
DrägerSensors PS2	Measuring Range	Part Number	Price
Oxygen	0-25 Volume %	PAC3020	\$165.00
Carbon Monoxide	0-2000 ppm	PAC3021	\$250.00
Hydrogen Sulfide	0-100 ppm	PAC3022	\$250.00
Ammonia	0-300 ppm	PAC3023	\$275.00
Carbon Dioxide	0-5 Volume %	PAC3024	\$335.00
Chlorine	0-20 ppm	PAC3025	\$335.00
Hydrogen Cyanide	0-50 ppm	PAC3026	\$275.00
Organic Vapors	0-200 ppm	PAC3027	\$250.00



CATALOG NO. PAC300 PAC III PRICE: \$325.00*
***SENSOR IS NOT INCLUDED IN PRICE OF UNIT**



HAZMAT KIT

This kit is designed to aid in the initial assessment of potentially hazardous situations (e.g. chemical leaks, fires, and accidents involving toxic gases). The Deluxe HazMat Kit enables you to systematically identify chemical groups, as well as determine concentration levels of gases and vapors utilizing 17 types of short-term Dräger tubes. The evaluation of the test results can be performed on-site, without delay.



CATALOG NO. HZK100 HAZMAT KIT PRICE: \$1,449.00

MULTIWARN II



This is an intelligent, flexible multigas instrument for the simultaneous monitoring of up to five gas hazards, including combustible gases in % LEL, % by volume, and PPM over 45 toxic gases and oxygen. This deluxe monitor features patented infrared sensing technology (IR-HC & IR-CO₂), smart interchangeable sensors, an internal pump, and countless other features. The practical housing allows the Multiwarn II to be used as a portable and area monitor. The large illuminated display and three clearly arranged buttons allow for simple operation. It's extremely loud and bright alarms, and impressive capabilities makes the Multiwarn II the most advanced instrument of its kind.

CATALOG NO. MTW100..... MULTIWARN II..... PRICE: \$4,200.00*
CATALOG NO. MTW100K..... CALIBRATION KIT FOR MULTIWARN II..... PRICE: \$485.00
***SEE PAGE 211B FOR SENSORS, NOT INCLUDED IN PRICE.**

CLANDESTINE LAB INVESTIGATION KIT

Investigating clandestine drug laboratories is dangerous work. The investigator has the problem of dealing with dangerous violators, and the extreme health hazard of the laboratory itself. When illicit drugs such as methamphetamine, PCP and certain narcotics are manufactured, various hazardous gases can be inhaled. These gases can cause effects, ranging from mild irritation to choking, severe nausea and unconsciousness. Also, the gases can cause explosions. Therefore, it is imperative that the investigator can determine what gases are present. The CLIK1000 is made to assist the investigator in making this critical evaluation. The user simply inserts a sample tube into the pump, manually squeezes the pump to gather the sample. The tubes will test for ammonia (NH₃), phosphine (PH₃) and hydrochloric acid (HCL). If the chemical agent is present, the tube will change color and will determine at what concentration the gas is present.



Leading Particulars:

- Accuro bellows pump
- Deluxe tube opener
- 1 Box of 10 ammonia detector tubes
- 1 Box of 10 hydrochloric acid detector tubes
- 1 Box of 10 phosphine detector tubes
- Panorama Nova gas mask
- (1) Phosphine gas filter
- Tubes are available for many other gases that can be present in clandestine labs.



CATALOG NUMBER	DESCRIPTION	PRICE
CLIK1000.....	CLANDESTINE LAB INVESTIGATION KIT.....	PRICE: \$795.00
SFL2000A.....	PANORAMA NOVA WITH PHOSPHINE CANISTER.....	PRICE: \$191.00
CLIK1001.....	DETECTOR TUBES, PHOSPHINE/BOX OF 10.....	PRICE: \$49.00
CLIK1002.....	DETECTOR TUBES, AMMONIA/BOX OF 10.....	PRICE: \$46.00
CLIK1003.....	DETECTOR TUBES, HYDROCHLORIC/NITRIC ACID/BOX OF 10.....	PRICE: \$62.00

CMS UNIT



Dräger CMS, the new portable Chip Measurement System for gas and vapor spot measurements, combines the advantages of chemistry and electronics to provide accurate and reliable results. The system consists of two components—a substance-specific chip, and an analyzer. Each chip contains 10 capillaries which are filled with a special reagent material and are encased in a hard plastic housing. The chips are calibrated for up to 2 years. The analyzer employs optics and electronics to evaluate the chemical reaction within a capillary, determines a measurement value, and displays the result in a digital readout.

CATALOG NO. CMS100 PRICE: \$1,495.00*
***CHIPS SOLD SEPARATELY BELOW.**

Chip	Measurement Range (ppm)	Part Number	Price
Ammonia	2-50	CMS101	\$52.00
Ammonia	10-150	CMS102	\$52.00
Benzene	0.2-10	CMS103	\$136.00
Benzene	0.5-10	CMS104	\$136.00
Benzene	10-250	CMS105	\$136.00
Carbon Dioxide	200-3,000	CMS106	\$52.00
Carbon Dioxide	1000-25,000	CMS107	\$48.00
Carbon Dioxide	1-20 vol%	CMS108	\$48.00
Carbon Monoxide	5-150	CMS109	\$39.00
Chlorine	0.2-10	CMS110	\$52.00
Hydrochloric Acid	1-25	CMS111	\$67.00
Hydrochloric Acid	20-500	CMS112	\$67.00
Hydrocyanic Acid	2-50	CMS113	\$56.00
Hydrogen Sulfide	2-50	CMS114	\$39.00
Hydrogen Sulfide	20-500	CMS115	\$52.00
Hydrogen Sulfide	100-2,500	CMS116	\$52.00
Mercaptan	0.25-6	CMS117	\$98.00
Nitrogen Dioxide	0.5-25	CMS118	\$52.00
Nitrous Gases (NO + NO2)	0.5-15	CMS119	\$48.00
Nitrous Gases (NO + NO2)	10-200	CMS120	\$48.00
Perchloroethylene	5-150	CMS121	\$56.00
Petroleum Hydrocarbons	20-500	CMS122	\$73.00
Petroleum Hydrocarbons	100-3,000	CMS123	\$67.00
Phosgene	0.05-2	CMS124	\$88.00
Phosphine	1-25	CMS125	\$61.00
Phosphine	20-500	CMS126	\$61.00
Phosphine	200-5,000	CMS127	\$61.00
Propane	100-2,000	CMS128	\$73.00
Propanol	40-1000	CMS129	\$82.00
Sulfur Dioxide	0.4-10	CMS130	\$52.00
Sulfur Dioxide	5-150	CMS131	\$54.00
Toluene	10-300	CMS132	\$62.00
Training Chip	0.2-10	CMS133	\$16.00
Vinyl Chloride	0.3-10	CMS134	\$62.00
Vinyl Chloride	10-250	CMS135	\$62.00
Xylene	10-300	CMS136	\$54.00
Ethanol	100-2,500	CMS137	\$74.00
Iso-Propanol	40-1,000	CMS138	\$82.00
Methanol	20-500	CMS139	\$82.00

SECTION VII TABLE OF CONTENTS

Impression Evidence Footprints, Tire Tracks, Dust Prints and Tool Marks	
Casting Frames, Adjustable	215
Casting Kit, Plaster	216
Casting Kits, Silicone	214
Casting Techniques	217
DUROCAST™	220
Dust and Dirt Hardener, Jet-Pak	215
Electrostatic Print Lifting Kit	222
Footprint Lifters, Rubber	218
HARD•CORE BLUE™	218
Mixing Bowls, Flexible	216
Plaster, Casting	216
Putty, Casting	220
Silicone Rubber, Liquid	213
Silicone Rubber Release Agent	213
Silicone Rubber Thinner	213
SIRCHTRAK™	221
SNOWPRINT Wax	216
Zip-Top Plaster Casting	215

LOCATING AND PROTECTING IMPRESSION EVIDENCE

Often thought of as a form of evidence nearly as valuable as fingerprints, impression evidence must receive priority handling. Impression evidence may exist in the form of footprints or tire tracks, tool marks and even bite marks.

The obvious place to look for tire and footprint impressions is in the soil at or near the crime scene. Tool marks are found at the point of entry (or attempted points of entry) and bite marks are found on the victim. But all too often, invisible or very difficult-to-see impressions are also present. This might include dust prints or the impressions made from wet shoes on dry floors.

A visual search is made prior to any attempts to locate and collect other forms of physical evidence. When outdoors, protect the area by erecting barriers and posting sentries. If tire and footprint evidence is located and the weather is threatening, it may be necessary to erect a tent or similar shelter in order to protect the evidence.

IMPRESSION EVIDENCE

Many crime scene investigators view impression evidence as second only to fingerprints when considering the relative value of physical evidence.

Properly preserved impression evidence can provide a positive match to the shoes worn by the perpetrator, the tires on the vehicle driven by the perpetrator and the tools used to break into the premises.

Just like fingerprints, the various points of comparison are matched



between the crime scene evidence and the actual object making the impression.

And, just like fingerprints, no minimum number of points has been established. In other words, if the examiner is convinced that a perfect match exists, it doesn't matter if there are six or sixty points of comparison.

Various methods for the collection of impression evidence have evolved over the years.

LIQUID SILICONE RUBBER

This is the most economical medium for producing exact reproductions of footprints, tire prints, tool and jimmy marks, prints in dust, fingerprints, crash debris, firearms and the identification of disaster victims. Liquid silicone rubber is available in a 1 lb. (454 g) jar with catalyst.

Leading Particulars

- Flexible, exact reproductions of virtually any surface
- Long shelf life, unaffected by temperatures from -70° F to +500° F
- Quick-setting in three to five minutes, yet flows easily into hairline cracks
- Can be thinned to allow freer flowing

CATALOG NO. 634C PRICE: \$32.95



SILICONE RUBBER THINNER

Use silicone rubber thinner with No. 634C liquid silicone rubber compound. This product thins the compound, allowing it to flow more freely and cover a wider area. It is supplied in a 16 fl. oz. (473 ml) bottle.

CATALOG NO. 636C PRICE: \$21.95



SILICONE RUBBER RELEASE AGENT

This conveniently packaged product is used to aid in the separation of cured silicone from impression areas. It also works well with plaster and dental stone casting materials. Apply a thin, even coating over the surface to be preserved.

CATALOG NO. SRA10 PRICE: \$9.95



TIRE AND FOOTPRINT CASTING



NO. 1 SILICONE CASTING KIT

This economical, space-saving kit contains all the necessary materials needed for small casting applications.

No. SRK700 consists of:

- 1-No. 634C Liquid Silicone Rubber Jar, 1 lb.
- 1-No. TM1 Tube of Catalyst
- 1-No. KCP199 Steel Spoon
- 1-No. KCP198 Plastic Mixing Container, 1 1/2 pt.
- 1-No. KCP155 Spatula, 7", Steel Blade
- 1-No. SRA10 Aerosol Release Agent, 6 fl. oz.

CATALOG NO. SRK700 PRICE: \$65.50



NO. 2 SILICONE CASTING KIT

This is a complete field kit with added quantities of casting materials.

No. SRK800 consists of:

- 2-No. 634C Liquid Silicone Rubber Jars, 1 lb.
- 1-No. 636C01 Silicone Rubber Thinner, 4 fl. oz.
- 2-No. TM1 Tubes of Catalyst
- 1-No. SRA10 Aerosol Release Agent, 6 fl. oz.
- 1-No. KCP199 Steel Spoon
- 1-No. KCP198 Plastic Mixing Container, 1 1/2 pt.
- 1-No. KCP201 Plastic Mixing Container, 1/2 pt.
- 1-No. KCP155 Spatula, 7", Steel Blade
- 1-No. SRK8001 Molded Copolymer Carrying Case, Dimensions: 12 1/8" x 7 1/4" x 4 1/2" Weight: 4.92 lbs.

CATALOG NO. SRK800 PRICE: \$128.25

LIQUID SILICONE CASTING KIT

This is a complete field kit with all the materials for making accurate reproductions with liquid silicone. Materials furnished permit casting of tire and footprints in snow, mud and sand, as well as other casting requirements.

No. 640C consists of:

- 2- No. 634C Liquid Silicone Rubber Jars, 1 lb.
- 1- No. 636C Silicone Rubber Thinner, 16 fl. oz.
- 2- No. TM1 Tubes of Catalyst
- 1- No. SRA10 Aerosol Release Agent, 6 fl. oz.
- 1- No. 637C1 Gas Power Unit with Head, 6.5 oz. average
- 1- No. 642C Flexible Mixing Bowl, 4 1/4"
- 1- No. 643C Flexible Mixing Bowl, 4 3/4"
- 1- No. 644C Flexible Mixing Bowl, 5 1/4"
- 1- No. KCP155 Spatula, 7", Steel Blade
- 1- No. KCP142 Steel Mixing Spoon
- 1- No. SP1000 SNOWPRINT Wax
- 1- No. 639C4 Base Builder, 8 fl. oz.
- 1- No. 638C32 Dust and Dirt Hardener, 32 oz.
- 1- No. SK900 Tape Measure, Metric/English, 100ft/30m
- 25- No. 608E1 Evidence Tags with Ties
- 1- No. KCP200 Surface Brush
- 1- No. 638Y Spray Head Cleaner, 16 fl. oz.



- 1- No. FCF100 Casting Frame, 7 1/4" x 12" to 18"
- 1- No. 640C1 Professional Carrying Case, Textured Vinyl Leatherette-Finish, Nickel-Plated Steel Hardware Dimensions: 20 1/2" x 12" x 10" Weight: 22.3 lbs.

CATALOG NO. 640C PRICE: \$322.50

TIRE AND FOOTPRINT CASTING

ZIP-MIX™ PLASTER CASTING

Eliminate the mess and difficulty of mixing plaster—use ZIP-MIX™. Casting plaster must be mixed uniformly and all lumps eliminated. ZIP-MIX™ plaster ensures a uniform, smooth mixture every time. Simply combine water and plaster in the zip-top bag and knead with both hands until no lumps are felt. The ZIP-MIX™ set includes a pre-measured amount of plaster and water—enough to cast a full-sized adult footprint. Everything needed is in one convenient package.



No. ZMP100 consists of:

- 1-No. ZMP101 Jar of Pre-Treated Water, 16 oz.
- 1-No. ZMP102 Package of Plaster, 2 lbs.
- 1-No. ZTE031 ZIP-MIX™ Mixing Bag, 13" x 18"

CATALOG NO. ZMP100 **PRICE: \$19.95**

FOUR EASY STEPS



Step 1. Apply **SIRCHIE**'s dust and dirt hardener.*



Step 2. Pour water into zip-top bag and seal.



Step 3: Knead bag for one to two minutes.



Step 4: Pour into impression.*
*Optional accessories pictured.

JET-PAK DUST AND DIRT HARDENER COMBINATION

This is an efficient combination for preparing footprints and tire tracks found in loose soil, sand or mud. The propellant cartridge provides an even, fine mist under low pressure to ensure against impression damage. After treatment impressions can be made with silicone rubber, plaster or **HARD•CORE** casting materials.

No. 637C combination consists of:

- 1-No. 638Y Spray Head Cleaner, 16 fl. oz.
- 1-No. FCF100 Casting Frame, 7 1/4" x 12" to 18"
- 1-No. 638C Dust and Dirt Hardener
- 1-No. 637C1 Gas Power Unit with Head, 6.5 oz. average
- 1-No. 639C4 Base Builder, 8 fl. oz.



CATALOG NO.	DESCRIPTION	PRICE
637C	JET-PAK DUST AND DIRT HARDENER COMBINATION	\$79.95
638C	DUST AND DIRT HARDENER ONLY (1 GALLON)	\$24.95

ADJUSTABLE CASTING FRAMES

These all-aluminum, adjustable casting frames restrict the flow of casting compounds. Each size expands a full six inches in length. Manufactured out of 0.060" x 1 3/4" aluminum.

- CATALOG NO. FCF100 7 1/4" x 12" TO 18" PRICE: \$16.50
- CATALOG NO. FCF200 12" x 18" TO 24" PRICE: \$24.50



TIRE AND FOOTPRINT CASTING



SNOWPRINT WAX

Prior to making casts in snow, SNOWPRINT wax should be sprayed into the impression to prepare the surface for casting. SNOWPRINT locks the impression detail to avoid melting when the casting medium is applied. It is supplied in a 250 ml aerosol can.

CATALOG NO. SP1000 PRICE: \$15.95

CASTING PLASTER

This special formula plaster is for tire and footprint evidence. It contains an exothermic retarder to slow set-up while mixing and to reduce shrinkage while curing. It is supplied in a 10 lb. container.

CATALOG NO. 639C1 PRICE: \$12.95

FLEXIBLE MIXING BOWLS

These are highly flexible, self-cleaning mixing bowls that are ideal for mixing liquid silicone rubber, plaster, and **HARD•CORE**. The bowls feature a non-stick surface that is resistant to chemicals and petroleum products.

CATALOG NO.	DESCRIPTION/SIZE	PRICE
641C.....	3 1/2" DIAMETER BOWL	\$7.95
642C.....	4 1/4" DIAMETER BOWL	\$9.75
643C.....	4 3/4" DIAMETER BOWL	\$12.25
644C.....	5 1/4" DIAMETER BOWL	\$14.50
646C.....	4 PIECE SET	\$49.95



TIRE AND FOOTPRINT PLASTER CASTING KIT

This is a complete outfit for making exact reproductions of footprints and tire prints in snow, mud, sand and dirt. It is excellent for field investigations. Casting material (calcium sulfate) is finely ground for fast-setting and exact detailed reproduction. The kit is complete with application procedures and instructions.

No. 639C consists of:

- 1- No. 637C1 Gas Power Unit with Head
- 1- No. 638Y Spray Head Cleaner, 16 oz.
- 1- No. 638C16 Dust and Dirt Hardener, 16 oz.
- 1- No. 639C4 Base Builder, 8 oz.
- 1- No. 639C2 Water Container, 32 oz.
- 1- No. 642C Flexible Mixing Bowl, 4 1/4"
- 1- No. 643C Flexible Mixing Bowl, 4 3/4"
- 1- No. 644C Flexible Mixing Bowl, 5 1/4"
- 1- No. SRA10 Silicone Rubber Release Agent, 6 fl. oz.
- 1- No. KCP114 Retractable Measuring Tape, 6'
- 1- No. KCP155 Spatula, Steel Blade, 7"
- 1- No. KCP154 Pipette, with Suction Bulb
- 1- No. KCP142 Spoon, 12"
- 1- No. KCP200 Surface Brush
- 1- No. 639C1 Tire and Footprint Casting Plaster, 5 lbs.
- 1- No. 639C5 Wire Mesh Reinforcement, 2" x 4", 10 each
- 1- No. SP1000 SNOWPRINT Wax



- 1- No. FCF100 Casting Frame, Adjustable, 7 1/4" x 12" to 18"
- 1- No. STM1003 Modeling Clay, 1/4 lb.
- 24- No. 608E01 Evidence Tags, Pre-printed
- 1- No. 639C1 Professional Carrying Case, Textured Vinyl Leatherette-Finish, Nickel-Plated Steel Hardware
Dimensions: 20 1/2" x 12" x 10"
Weight: 20.92 lbs.

CATALOG NO. 639C PRICE: \$249.50



Due to their size, tire and footprint impressions require a different casting medium than tool marks. For many years, crime scene investigators preferred "Plaster of Paris" as their first choice for recovering large impressions. In recent years, investigators have switched to die stone or dental stone materials. Die stone or dental stone forms a very durable cast, requires no reinforcement and demonstrates no apparent shrinkage.

HARD•CORE BLUE™ CASTING TECHNIQUES

HARD•CORE BLUE™ is used in the same manner as casting plaster. Follow these procedures for consistently good casts:

- 1. Remove any debris, twigs or leaves found lying on top of the impression. **DO NOT** remove any object imbedded in the impression.
- 2. Place a casting frame (No. FCF100) around the impression.
- 3. When casting in loose soil or sand, prepare the surface by adding several light coatings of dust and dirt hardener (No. 637C). Allow two to three minutes of drying time between coatings. Hard soil or clay generally will not require hardening.
- 4. Apply a light coating of silicone release agent (No. SRA10) to the impression.
- 5. **A.** Mix the required amount of **HARD•CORE BLUE™** (approximately one minute of mixing is sufficient). **B.** Pour into the impression. The entire mixture should be a uniform color. **C.** Be certain to break the fall of the mixture using a stick, spoon or spatula. Begin pouring around the edges and allow the mixture to flow over the impression. Generally, the cast should be a 1/2" to 3/4" thick. No reinforcement is required.



STEPS 1 AND 2



STEPS 3 AND 4



STEP 5A



STEP 5B



STEP 5C

CASTING IN STANDING WATER

It is possible to make a cast of an impression that is found under water using the following procedure.

- 1. **A.** Carefully place a restrictor/casting frame around the impression. **B.** If possible, the restrictor should be wide enough so that it stands above the surface of the water.
- 2. Lightly sprinkle **HARD•CORE BLUE™** compound to completely cover the impression to a thickness dependent on the water depth.
- 3. Mix a quantity of **HARD•CORE BLUE™** with mixing solution and pour the mixture on top of the compound covering the impression. Be certain to break the fall of the mixture with a stick, spoon or spatula.
- 4. Allow at least 30 minutes for setup. Remove the cast and allow at least 24 hours of drying time before any further examination or handling.



STEP 1A



STEP 1B



STEP 2



STEPS 3 AND 4

TIRE AND FOOTPRINT CASTING



HARD•CORE BLUE™ DENTAL STONE CASTING MATERIAL

HARD•CORE BLUE™ is an all-purpose, gypsum-based casting material that offers Herculean strength, accurate reproductions, simplicity of use and long-term economy. It is a “dental stone” casting material proven to be the most efficient and practical method for casting tire and footprint impressions. Its superior strength eliminates the need for reinforcement. Typical casts are 1/2" to 3/4" thick (compared with several inches thick using plaster), and offer some amazing properties. It has been stored for months on end in the trunk of a vehicle with no apparent loss of efficiency—from sub-freezing to temperatures in excess of 100° F (38° C). It sets up in a shorter time and has only a minor exothermic reaction. Only larger impressions require damming or flow restriction. It is supplied in pre-measured amounts. And, a specially treated blue water solution is supplied with each hard-core set. This solution contains a freeze retardant, allowing it to be stored in temperatures below 32° F. It's ideal for casting in snow.

CATALOG NO.	DESCRIPTION	PRICE
HCB2001	HARD•CORE CASTING MATERIAL, 5.7 LBS.	\$16.95
HCB2002	HARD•CORE BLUE™ SOLUTION, 32 FL. OZ.	\$4.95
HCB3001	HARD•CORE CASTING MATERIAL, 11.4 LBS.	\$29.25
HCB3002	HARD•CORE BLUE™ SOLUTION, 64 FL. OZ.	\$7.75

ZIP-MIX™ HARD•CORE CASTING COMBINATIONS

Pre-measured hard-core casting material and **HARD•CORE BLUE™** solution ensure a uniform mixture every time. Simply add the blue solution to the zip-top bag and knead with both hands until smooth. Then, pour into prepared impression area.

No. HCB100Z consists of:

- 1-No. HCB100Z **HARD•CORE** Casting Material, 2.2 lbs.
 - 1-No. HCB400Z **HARD•CORE BLUE™** Solution, 16 fl. oz.
- (This combination is enough for two footprints or a partial tire track)

CATALOG NO. HCB100Z **PRICE: \$13.95**

No. HCB100 consists of:

- 1-No. HCB100Z1 **HARD•CORE** Casting Material, 4.4 lbs.
- 1-No. HCB2002 **HARD•CORE BLUE™** Solution, 32 fl. oz.

CATALOG NO. HCB100 **PRICE: \$25.95**



RUBBER FOOTPRINT LIFTERS

The **SEARCH®** rubber footprint lifters are uniquely designed to allow for an accurate transfer of foot or footwear prints from dusty and/or dirty surfaces. They are particularly useful when dealing with lightly covered surfaces because they don't generate static electricity like standard lifting tapes. These lifters may be reused if they are properly cleaned and rejuvenated with No. 647C101 rejuvenator cleaner spray. Two 6" x 15" rubber footprint lifters—one black and one white—and a bottle of rejuvenator cleaner spray are supplied with each order.

CATALOG NO. 647C100 **PRICE: \$26.50**

FOOTPRINT RESIDUE LIFTERS

These unique lifting devices are coated with super-sensitive acrylic adhesive for lifting the most minute particles. Simply remove the adhesive protector, apply to the area, lift and mount on backing material supplied with each lifter. Lifters are 6" x 15" and are supplied in a package of 12. Lifters are supplied with twelve 6" x 15" x 0.010" transparent plastic backing sheets.

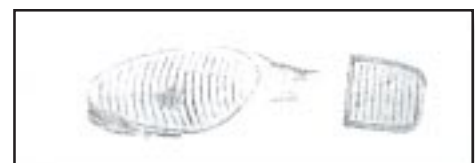

CATALOG NO. FR001 **PRICE: \$24.25/12**

**HARD•CORE
TIRE AND FOOTPRINT CASTING KIT**

This complete kit includes the materials and supplies for casting tire and footprint impressions at the crime scene. Hard-core casting material is provided to permit detailed reproduction of impression evidence. Resulting casts are rock-hard and require no reinforcement. Use this kit for recovery of impressions found in snow, mud, sand and soil.

No. 639HCB consists of:

- 1-No. KCP223 Container, P/S Hinged, 7" x 3 1/2" x 1" which contains:
 - 1- No. KCP155 Spatula, 7", Steel Blade
 - 1- No. EPS30W Photo Evidence Ruler
- 25- No. 608E1 Evidence Tags with Ties
- 1-No. HCB2001 **HARD•CORE** Casting Material, 5.7 lbs.
- 1-No. HCB2002 **HARD•CORE BLUE™** Mixing Solution, 32 fl. oz.
- 1-No. 637C1 Gas Power Unit with Head, 6.5 oz. average
- 1-No. 638C16 Dust and Dirt Hardener, 16 oz.
- 1-No. 638Y Spray Head Cleaner, 16 fl. oz.
- 1-No. 638Y Spray Head Cleaner, 16 fl. oz.
- 1-No. STM1003 Clay Stick, 1/4 lb.



- 1-No. 642C Flexible Mixing Bowl, 4 1/4"
- 1-No. 643C Flexible Mixing Bowl, 4 3/4"
- 1-No. 644C Flexible Mixing Bowl, 5 1/4"
- 1-No. SP1000 SNOWPRINT Wax
- 1-No. SRA10 Aerosol Release Agent, 6 fl. oz.
- 1-No. FCF100 Casting Frame, 7 1/4" x 12-18"
- 1-No. 639C4 Base Builder 8 fl. oz. (237 ml)
- 1-No. KCP200 Surface Brush
- 1-No. SK900 Tape Measure, Metric/English, 100ft/30m
- 1-No. KCP142 Steel Mixing Spoon
- 1-No. 638HCB1 Professional Carrying Case, Textured Vinyl Leatherette-Finish, Steel Hardware, 20 1/2" x 12" x 10" Weight: 26.22 lbs.

CATALOG NO. 639HCB PRICE: \$306.50

**MASTER HARD•CORE
AND LIQUID SILICONE CASTING KIT**

This complete field kit contains all the materials necessary to recover most forms of impression evidence found at crime scenes. From tool marks to tire tracks, this kit offers efficient, thorough evidence collection. The flexibility of this kit becomes evident when confronting various environmental situations.

No. CSP1000 consists of:

- 1-No. KCP223 Container, P/S Hinged, 7" x 3 1/2" x 1" which contains:
 - 1-No. KCP155 Spatula, 7", Steel Blade
 - 1-No. EPS30W Photo Evidence Ruler
 - 1-No. STM1003 Clay Stick, 1/4 lb.
 - 1-No. TM1 Silicone Catalyst
- 1-No. SK900 Tape Measure, Metric/English, 100ft/30m
- 1-No. EIL01R **SIRCHSEAL™** Label Roll
- 1-No. FCF100 Casting Frame, 7 1/4" x 12-18"
- 1-No. HCB2001 **HARD•CORE** Casting Material, 5.7 lbs.
- 1-No. HCB2002 **HARD•CORE BLUE™** Mixing Solution, 32 fl. oz.
- 1-No. SRA10 Aerosol Release Agent, 6 fl. oz.
- 1-No. 639C Silicone Rubber Thinner, 16 fl. oz.
- 1-No. 638C16 Dust and Dirt Hardener, 16 fl. oz.
- 1-No. SP1000 SNOWPRINT Wax
- 1-No. 637C1 Gas Power Unit with Head, 6.5 oz. average
- 1-No. 638Y Spray Head Cleaner, 16 fl. oz.
- 1-No. 634C Liquid Silicone Rubber, 1 lb.
- 1-No. 639C4 Base Builder 8 fl. oz. (237 ml)



- 1-No. 642C Flexible Mixing Bowl, 4 1/4"
- 1-No. 643C Flexible Mixing Bowl, 4 3/4"
- 1-No. 644C Flexible Mixing Bowl, 5 1/4"
- 1-No. KCP200 Surface Brush
- 1-No. KCP142 Steel Mixing Spoon
- 1-No. TI3106 Technical Instructions
- 1-No. CSP10001 Professional Carrying Case, Textured Vinyl Leatherette-Finish, Steel Hardware Dimensions: 20 1/2" x 12" x 10" Weight: 28.38 lbs.

CATALOG NO. CSP1000 PRICE: \$339.95

TOOL MARK IMPRESSIONS



DUROCAST™ CASTING PUTTY

Forced entry of any premises usually is accomplished with the aid of tools or jimmying devices. The indentations left by these tools should be preserved using **SIRCHIE**®'s DUROCAST™ impression compound. Its putty-like consistency enables the user to make impression castings on vertical or horizontal surfaces. For example, castings may be made of tools marks, firing print marks and breach face marks, with exact detail.



Hammer Claw and Reproduction



This is an actual cast of the ink depth of a 20 dollar bill.

SEARCH DUROCAST™ IMPRESSION COMPOUND

This remarkable new casting compound is one of the most accurate products available for impression reproductions. DUROCAST™ is so precise in reproduction that it will reproduce the ink depth of U.S. paper currency. DUROCAST™ is ideal for reproducing impressions in metals, wood, plastic and paper. NO RELEASE AGENT IS REQUIRED FOR SEPARATION. It has a shelf life of more than two years in a tightly sealed container. Compound includes a No. DOC3 measuring spoon. Castings remain flexible indefinitely. DUROCAST™ is non-toxic. Setup time is typically eight to 12 minutes.

CATALOG NO.	DESCRIPTION	VOLUME	NET WEIGHT	PRICE
DOC1001	DUROCAST™ WITH CATALYST	1 OZ.	1 OZ.	\$14.95
DOC1002	DUROCAST™ WITH CATALYST	2.5 OZ.	2.5 OZ.	\$27.95
DOC1001	DUROCAST™ WITH CATALYST	24 OZ.	24 OZ.	\$129.95

DUROCAST™ MIXING PROCEDURES



STEP 1. Use one level scoop of base material.



STEP 2: Flatten base material in palm of hand and make indentation with overturned scoop.



STEP 3: Squeeze a line of catalyst the length of the indentation and mix thoroughly by hand.



STEP 4. Press compound into impression. Remove after 8 to 12 minutes.

DUROCAST™ IMPRESSION COMPOUND KIT

SIRCHIE®'s DUROCAST™ impression casting compound highlights this convenient field kit. Extremely fine detail is available for impressions ranging from striations on a bullet casting to a footprint in hardened concrete.

No. FR001 consists of:

- 1-No. DOC100IC DUROCAST™ Impression Compound, 24 fl. oz.
- 1-No. DOC100C DUROCAST™ Impression Compound Catalyst, 5 g
- 1-No. DOC100S Plastic Measuring Spoon
- 1-No. DOC1 Carrying Case, Texturized, Molded Plastic
Dimensions: 12 1/8" x 7 1/4" x 5 1/2"
Weight: 3.72 lbs.

CATALOG NO. DOC1000 PRICE: \$149.95





Original Tire

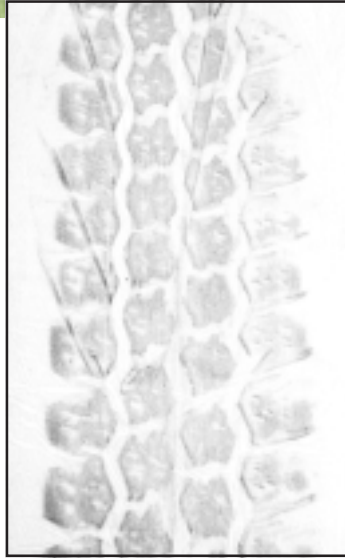

SIRCHTRAK™ Tread Impression



Dirt Impression

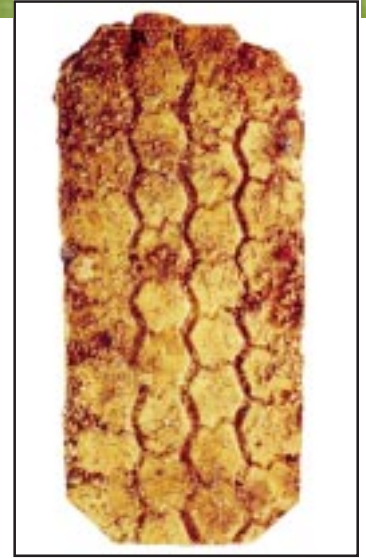

Hard-Core Casting

TIRE TREAD AND FOOTWEAR PRINT-OUT SYSTEM

To accurately compare tire print evidence, the track left by the suspect tire should be recorded under the pressure of the vehicle. **SIRCHTRAK™** is a new, easy-to-use “drive over” system that gives a permanent record of the tire under load, making comparisons to casts and/or photographs more reliable. **SIRCHTRAK™** eliminates dusting or inking of tires to be examined.

HOW IT WORKS

Simply lay a sheet of **SIRCHTRAK™** on the impression board and drive the vehicle over it. The pressure of the tire under load causes the interleaved carbon carrier to transfer to the adhesive-coated receiver sheet. Simply peel off the carbon carrier and discard.

BENEFITS

Unlike conventional methods of making test tracks, the tire tread imprints are exact, uniform, high-contrast reproductions which become an accurate “signature” of the suspect tire. The **SIRCHTRAK™** print out is perfect for comparison purposes and ultimate courtroom presentations.

SIRCHTRAK™ enables the investigator to more precisely examine the following points of comparison:

- 1. Overall tread design
- 2. Dimensions between ridges and sections
- 3. Positions of ridges relative to one another
- 4. Unusual wear, markings and distinctive features
- 5. Amount and type of wear

No. STT100 consists of:

- 10- No. STT103 **SIRCHTRAK™** Print-Out Sheets
- 1- No. STT102 **SIRCHTRAK™** Impression Board
- 1- No. STT101 Sheet of Foam Rubber Material, 11" x 17" (for use when taking shoe prints)



*Drive a vehicle over **SIRCHTRAK™**.*



*This is the resultant **SIRCHTRAK™** print.*



*The **SIRCHTRAK™** is also ideal for recording footwear impressions.*

CATALOG NO. STT100 SIRCHTRAK™ SYSTEM PRICE: \$99.50

ELECTROSTATIC PRINT LIFTING KIT

The **SIRCHIE**® No. ESP100 electrostatic print lifting kit is one of the most advanced units of its type available today. It was designed to achieve top-quality dust print lifts within a variety of crime scene settings. The technique of lifting a dust print is based on the principle of electrostatic induction: any charged insulator induces an equal but opposite charge on another insulator in close proximity. The opposite charges induced in the dust particles cause them to be attracted to the two opposite poles created by the electrostatic lifting mats—creating a dust impression of any dust patterns that are present. The No. ESP100 generates a pulsed DC electrostatic field of up to negative 12,000 volts at very low current levels. This high voltage creates the static charge necessary for dust print lifting. The dust print—when transferred to the lifting mat—will appear as precise as a mirror image of the print lift on the floor (or other surfaces).

No. ESP100 Leading Particulars

- **Two charging rates—high and tickle**
- **Output voltage LED bar graph readout**
- **Charging Current—High:** 100 mA typical
- **Charging Current—Trickle:** 35 mA typical
- **Charging Source:** 120VAC adaptor, 12VAC output
- **Control/Information Panels:** Black plexiglass (3mm thick), white screening
- **Electrostatic Mats:** Metallized polyester (0.005")/vinyl (0.035")
16" L x 16" W (41mm x 41 mm)
- **High Voltage Application Time:** 30 sec. nominal
- **Housing:** Vacuum-formed ABS black plastic, 0.06" thick
- **Internal Batteries**
- **Lifting Mats:** Vinyl (0.035" thick), 17" L x 16" W
- **Voltage Output:** 12,000 volts nominal (peak with no load)



about THE NO. ESP100 SYSTEM ...

The No. ESP100 system utilizes a portable, battery-powered charge generator. Sealed nickel-cadmium cells are the power source. With the batteries fully charged, many print lifting operations (typically 50-100) may be accomplished before recharging if necessary. The static charge generator—along with the entire system—is fully insulated to prevent accidental electric shock while operating this unit. Once switched on, the applied electrostatic charge will automatically shut off after a preset period (30 seconds). It is unnecessary for the investigator to touch or handle the lifting mats while the static charge is applied.

No. ESP100 consists of:

- 1-No. ESP1002 Control Unit
- 2-No. ESP1003 Electrostatic Mat
- 1-No. ESP1004 Charging Transformer
- 1-No. ESP1005 Steel Ruler, 12"
- 1-No. ESP1006 Anti-Static Cloth
- 6-No. ESP1007 Sets of 2 Lifting Mats
- 1-No. FPR400 Unified Fingerprint Roller, 4"
- 2-No. KCP235 D-Cell Batteries, Alkaline
- 1-No. PL1000 Flashlight, Clear Acrylic, D-Cell
- 1-No. SF0073 Disposable Shoe Cover Pair
- 1-No. ESPHVC Hi-Voltage Cable Leads, 8-Foot Red/Black
- 1-No. ESP1001 Carrying Case, Black Polypropylene, Custom Foam Insert
Dimensions: 21 3/4" x 21 3/4" x 8 1/2"
Weight: 25.28 lbs.
- 1No. ESPCC Lifting Mat Carrying Case

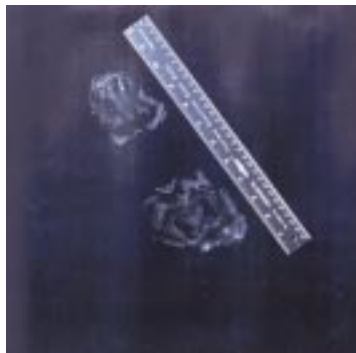

This is the electrostatic mat with a lifted footprint.



Control Unit

CATALOG NO. ESP100.....ELECTROSTATIC PRINT LIFTING KIT..... PRICE: \$695.00
CATALOG NO. ESP1007..... SET OF 2 LIFTING PADS PRICE: \$5.90

FORENSIC EVIDENCE COLLECTION KITS

Sex Crimes Evidence Collection Kits

Sexual assaults usually result in a physical struggle between the victim and the assailant. As a result of this struggle and the nature of sex crimes, physical evidence in some form is available to the investigator. **SIRCHIE**'s professionally designed and assembled sex crimes evidence collection kits ensure that the collection and preservation of sexual assault evidence is systematic, comprehensive and thorough.

Crime Scene DNA Evidence Collection Kits

The possibility of confirming an individual's identity by DNA matching makes the collection of cellular material left at the crime scene mandatory. Each scene presents its own problems and unless the investigator is prepared to collect any and all potential sources of DNA, valuable evidence may be lost. The most frequent forms of forensic evidence available for DNA testing are fresh blood, semen, hair roots and clothing stained by physiological fluids. **SIRCHIE**'s crime scene DNA evidence collection kits provide all the necessary materials required for the collection of this type of evidence.

Blood Alcohol/Urine Specimen Collection Kits

The blood alcohol/urine specimen collection kits are designed to provide for the safe and efficient collection, handling and mailing of blood and/or urine specimens. The kits feature step-by-step instructions, individually protected blood collection tubes and U.S. Postal Service-approved tube mailers.

Custom Kits

Recognizing that requirements for investigative procedures vary from state to state, we offer the option of manufacturing customized collection kits. We customize collection kits for sexual assault (victim and suspect), DNA, blood alcohol and urine samples. We maintain a complete graphic arts and printing facility to ensure the best quality, and fastest turn-around of your orders. A minimum of 100 kits is required for all custom orders.

SECTION VIII TABLE OF CONTENTS

Forensic Evidence Collection Kits

Blood Alcohol Collection Kit	230
Blood Alcohol/Urine Specimen Kit	230
DNA Evidence Collection Kit	229
Sex Crimes Kits	225, 228
Suspect Evidence Kits	227, 228
Sexual Assault Kits	226-227
Sexual Battery Examination Kit	228
Evidence Collection Kit Production	231



SEX CRIMES EVIDENCE COLLECTION

COLLECTION AND PRESERVATION

When possible, bloodstained materials should be sent to the lab for analysis

- Air-dry the bloodstained material
- Place the suspect material in a paper bag, affix an evidence collection label and mark with the date, exhibit number and initial. Seal the bag with an appropriate evidence integrity medium.
- Each bloodstained item must be packaged separately and only after it is thoroughly air-dried.

Collect standards for comparison

When bloodstained materials cannot be sent to the lab for analysis

- Using a clean blade, scrape the dried blood onto a clean piece of paper.
- Fold and place each paper into the appropriate rape kit envelope
- Initial, date and assign exhibit numbers to all envelopes and seal
- Preserve and package the blade
- Collect standards for comparison

When a sufficient quantity of liquid blood is available

- Fill vacutainer with blood
- Initial, date and assign an exhibit number to the vacutainer

When a whole blood sample is not available

- Using a gauze pad, soak up the moist blood
- Air dry the pad
- Place the pad in the appropriate rape kit evidence envelope; initial, date and assign an exhibit number
- Collect standards for comparison

Collecting blood standards for comparison

- Have a qualified individual collect whole blood from the victim and all suspects
- Label vacutainers with all pertinent information

DNA Analysis

- The possibility of confirming an individual's identity by DNA matching makes the collection of physiological evidence imperative. To assist in the proper collection of liquid or whole blood samples for DNA matching, SIRCHIE places a lavender-topped vacutainer containing EDTA in each of its sex crimes evidence collection kits.

Collecting saliva samples

- Air dry the saliva stained material on a piece of paper
- Place the suspect material in a paper bag, affix an evidence collection label and mark with the date, an exhibit number and initial.
- Each saliva stained item must be packaged separately, and only after it is thoroughly air dried.
- Collect standards for comparison

Collecting saliva standards for comparison

- Have the victim and the suspect(s) swab the inside of the mouth with the cotton swabs provided in the rape kit. Air dry and place in the appropriate envelope.
- Initial, date and assign exhibit numbers to all envelopes and seal.

Collecting semen samples

- Air dry the semen-stained material on a clean piece of paper
- Place the suspect material in a paper bag, affix an evidence collection label and mark with the date, an exhibit number and initial. Seal the bag with an appropriate evidence integrity medium.
- Each semen-stained item must be packaged separately and only after it is thoroughly air dried.

SEX CRIMES KIT

SIRCHIE®'s sex crimes investigation kit offers a comprehensive collection package for sex-related cases. This kit contains all the materials necessary for a complete, thorough and professional investigation regardless of the type of crime—rape, sodomy or carnal abuse. The No. CC100 meets two vital concerns of evidence collection:

1. Proper evidence collection materials.
2. Preservation of the evidence once it is collected

Leading Particulars

- Each collection envelope is color-coded and numbered
- Complete instructions are printed for each step
- Logical collection procedures coincide with medical treatment
- Physiological samples are taken with sterile materials
- Kits include materials for DNA processing
- Chain-of-possession label is preprinted directly on kit
- Each kit is factory-integrity-sealed and stamped with a lot number and expiration date



No. CC100 consists of:

- 1-No. 999311 FDA Manufacturer's Insert
- 1-No. CC1001 Chipboard Box, Factory-Sealed
- 1-No. CC100S Additional Information Card
- 1-No. CC101 Debris Collection Envelope
- 1-No. CC102 Genital Swabbing Envelope with One Inner Envelope and Sterile Pad
- 1-No. CC103 Dried Secretions Envelope with Two Inner Envelopes and Sterile Pads
- 1-No. CC104 Comb and Pubic Hair Combing Envelope with Inner Envelope
- 1-No. CC105 Pubic Hair, Pulled Envelope with Inner Envelope
- 1-No. CC106 Head Hair, Pulled Envelope with Inner Envelope
- 1-No. CC107 Fingernail Scrapings Envelope with Two Inner Envelopes and Two Scrapers
- 1-No. CC108 Saliva Sample Envelope with Inner Envelope and Specimen Disc
- 1-No. CC109 Smear and Swab Specimens, Three Double Slide Holders and Six Slides, Labeled
- 4-No. CC1094 Swab Boxes
- 1-No. CC110 Whole Blood Sample Envelope with 10 ml Blood Collection Tube
- 1-No. CC110A Blood Collection Tube, 7 ml, with EDTA for DNA Blood Analysis
- 1-No. CC111 Nasal Mucous Sample Envelope with Towelette
- 2-No. EIL021 Evidence "Police Seal" Labels
- 1-No. KCP139 Pair of Tweezers, Plastic, 4 3/4"
- 5-No. KCP160 Swabs, Sterile, Cotton-Tipped, Package of Two
- 1-No. KCP161 Fingernail Clippers
- 1-No. KCP206 Biohazard Label, 1" x 1 1/4" Black on Orange



CATALOG NO. CC100..... PRICE: \$14.95

**SEXUAL ASSAULT VICTIM
EVIDENCE COLLECTION KIT**

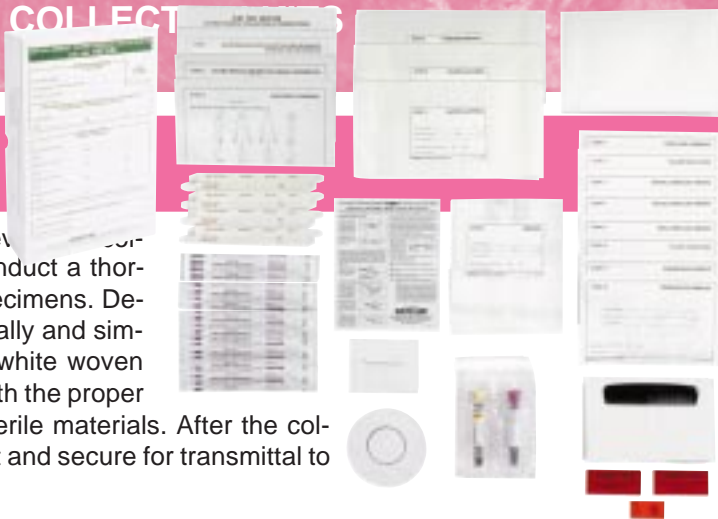

This is **SIRCHIE**®'s most comprehensive sexual assault victim evidence collection kit. It incorporates all the essential items necessary to conduct a thorough assemblage and preservation of all pertinent evidentiary specimens. Detailed instructions allow hospital personnel to systematically, logically and simply collect physiological samples. Each sturdy, 24 lb. (90 g/m2) white woven envelope is numbered so that the selection sequence coincides with the proper medical treatment. All physiological samples are secured with sterile materials. After the collection process is completed, simply replace the materials in the kit and secure for transmittal to the crime lab for proper analysis.

No. VEC100 consists of:

- 1-No. 999311 FDA Manufacturer's Insert
- 2-No. KCP118 Integrity Seals
- 1-No. KCP206 Biohazard Label, 1" x 1 1/4" Black on Orange
- 1-No. VEC1001 Kit Box, Factory-Sealed
- 1-No. VEC1002 Kit Instruction Sheet
- 1-No. VEC101 Authorization for Collection and Release Form, 3-Part
- 1-No. VEC102 Victim Medical History and Assault Information Form, 3-Part
- 1-No. VEC103A Foreign Material Bag with 23" x 35" Paper Sheet
- 1-No. VEC103B Panties Bag
- 2-No. VEC103C Outer Clothing Bags
- 1-No. VEC104 Debris Collection Envelope with Paper Bindle, Swab Box and Nail Scraper

- 1-No. VEC105 Pubic Hair Combing Envelope with Towel and Plastic Comb
- 1-No. VEC106 Pulled Pubic Hairs Envelope
- 1-No. VEC107 Vaginal Swabs and Smear Envelope with Slides, Sterile Swabs and Boxes
- 1-No. VEC108 Rectal Swabs and Smear Envelope with Slides, Sterile Swabs and Boxes
- 1-No. VEC109 Oral Swabs and Smear Envelope with Slides, Sterile Swabs and Boxes
- 1-No. VEC110 Pulled Head Hairs Envelope
- 1-No. VEC111 Known Saliva Sample Envelope with Specimen Disc
- 1-No. VEC112 Known Blood Sample Envelope with 6 ml ACD and 7 ml EDTA Blood Tubes
- 1-No. VEC113 Anatomical Drawings Form, 3-Part NCR
- 1-No. VEC114 Law Enforcement Forms Envelope

CATALOG NO. VEC100 PRICE: \$16.95

WESTERN SEXUAL ASSAULT EVIDENCE COLLECTION KIT

A special task force in a western state wanted to establish uniformity by having everyone use the same sexual assault kit. **SIRCHIE**®, in cooperation with that task force, developed the No. COL100 and it is now offered to all agencies.

No. COL100 consists of:

- 1- No. 999311 FDA Manufacturer's Insert
- 1- No. COL1001 Kit Envelope, 10" x 13"
- 1- No. COL1002 Male Victim Procedure Instruction Sheet
- 1- No. COL1003 Authorization Form, 3-Part NCR
- 1- No. COL1004 Sexual Assault Incident Form
- 2- No. COL101 Paper Drapes, 40" x 48"
- 1- No. COL102 Trace Evidence Envelope
- 1- No. COL103 Blood Collection Tubes Packet, 6ml ACD and 7ml tube with EDTA
- 1- No. COL104 Oral Swabs and Slide Envelope
- 1- No. COL104S Slide with Mailer Labeled "Oral"
- 1- No. COL105 Pubic Hair Combing Envelope with Plastic Comb
- 1- No. COL106 Pubic Hair Control Envelope
- 1- No. COL107 Anal Swabs and Slide Envelope
- 1- No. COL107S Slide with Mailer Labeled "Anal"
- 1- No. COL108 Vaginal/Penile Swabs and Slide Envelope
- 1- No. COL108S Slide with Mailer Labeled "Vaginal Motility"

- 1- No. COL109 Cervical Swabs and Slide Envelope
- 1- No. COL109S Two Slides and Double Mailer Labeled "Vaginal and Cervical"
- 1- No. COL110 Foreign Stains on Body Envelope
- 1- No. COL111 Fingernail Scrapings Envelope with Paper Bindle and Plastic Scraper
- 1- No. COL112 Buccal Swabs Envelope
- 1- No. COL113 Head Hair Control Envelope
- 1- No. COL114 Additional Envelope as Needed
- 1- No. EIL021 Evidence "Police Seal" Label
- 11- No. KCP160 Swabs, Sterile, Cotton-Tipped, Pkg. of 2
- 1- No. KCP206 Biohazard Label, 1" x 1 1/4", Black on Orange
- 14- No. KCP118 Evidence Seals



CATALOG NO. COL100 PRICE: \$10.95

SUSPECT EVIDENCE COLLECTION KIT

Systematically collect and preserve vital evidence with the new No. SEC100 suspect kit from **SIRCHIE®**. The step-by-step organization simplifies the collection procedure, prevents errors and ensures that integrity and quality are maintained throughout the evidence-gathering process. The No. SEC100 provides the means to determine culpability and innocence by linking the perpetrator and victim physiologically. All the necessary components for a complete and thorough processing of the suspect are included. Establish standardization of evidence and maintain the chain of possession with the newest evidence collection kit from **SIRCHIE®**.

No. SEC100 consists of:

- 1-No. 999311 FDA Manufacturer's Insert
- 1-No. KCP118 Integrity Seal
- 1-No. KCP206 Biohazard Label, 1" x 1 1/4" Black on Orange
- 1-No. SEC1001 Kit Envelope, Factory-Sealed
- 1-No. SEC1002 Instruction Sheet
- 2-No. SEC101A Outer Clothing Collection Bags
- 1-No. SEC101B Underpants Bag
- 1-No. SEC102 Foreign Material Collection Envelope, with Sterile Swabs and Scraper



- 1-No. SEC103 Pubic Hair Combing Envelope with Towel and Comb
- 1-No. SEC104 Pulled Pubic Hairs Envelope
- 1-No. SEC105 Pulled Head Hairs Envelope
- 1-No. SEC106 Known Saliva Sample Envelope with specimen Disc
- 1-No. SEC107 Known Blood Sample Bag Packet with 6 ml ACD and 7 ml EDTA Blood Tube
- 1-No. SEC108 Anatomical Drawings Form, 3-Part

CATALOG NO. SEC100 PRICE: \$8.95

SOUTHWESTERN SEXUAL ASSAULT EVIDENCE COLLECTION KIT

Following the Texas Attorney General's *Evidence Collection Protocol*, 1998 edition, **SIRCHIE®** constructed a sexual assault evidence collection kit to meet their specs. The No. TX100 has been so popular, it is now offered to all agencies.

No. TX100 consists of:

- 1-No. TX1001 Kit Box, 10 1/2" x 7" x 3"
- 1-No. TX1002 Evidence Collection Instructions
- 1-No. TX101 Request for Medical Exam and Release of Medical Records Form, 3-Part
- 1-No. TX102AC Examination and Forensics Report Form, Pages 1-3, 3-Part NCR
- 1-No. TX102EL Body Diagram Forms, Various, 3-Part NCR
- 1-No. TX103 Oral Swabs and Smear Envelope
- 1-No. TX104A Foreign Material Bag with 23" x 45" Paper Sheet
- 1-No. TX104B Undergarments/Diaper Bag
- 2-No. TX104C Outer Clothing Bag
- 1-No. TX105 Head Hair Combing Envelope with Towel and Plastic Comb
- 1-No. TX106 Pulled Head Hair Envelope
- 1-No. TX107 Debris Collection Envelope with Paper Bindle, Sterile Swabs and Box
- 1-No. TX108 Anal Swabs and Smear Envelope
- 1-No. TX109 Vaginal/Penile Swabs and Smear Envelope
- 1-No. TX110 Pubic Hair Combing Envelope with Towel and Plastic Comb

- 1-No. TX111 Pulled Pubic Hair Envelope
- 1-No. TX112 Fingernail Scrapings Envelope with 2 Each Paper Bindles and Scrapers
- 1-No. TX113 Known Blood Sample Blood Collection Tube, 7 ml, with EDTA
- 1-No. TX114 Known Saliva Sample Envelope with Sterile Swabs and Box
- 1-No. TX115 Receipt of Information Form, 3-Part NCR
- 1-No. TX116 Authorization to Assign Payment Form, 3-Part NCR
- 1-No. 999311 FDA Manufacturer's Insert
- 1-No. KCP206 Biohazard Label, 1" x 1 1/4", Black on Orange
- 1-No. KCP214 Pencil, Sharpened
- 2-No. LVSS1003 Evidence Police Seals



CATALOG NO. TX100 PRICE: \$12.96

FORENSIC EVIDENCE COLLECTION KITS



HOSPITAL SEX CRIMES KIT

Constructed to meet the rigid specifications of a large hospital in the northeast where speed and accuracy are a must, the No. CC100WP is simple to use and has easy-to-follow directions printed on each envelope. All of the materials needed for proper evidence collection are contained in one, easy-to-store chipboard kit box.

No. CC100WP consists of:

- 1-No. 999311 FDA Manufacturer's Insert
- 1-No. CC100WP1 Chipboard Box, Factory-Sealed
- 1-No. CC101WP Debris Collection Envelope
- 1-No. CC102WP Comb and Head Hair Combing Envelope with Inner Envelope
- 1-No. CC103WP Head Hair, Pulled Envelope with Inner Envelope
- 1-No. CC104WP Comb and Pubic Hair Combing Envelope with Inner Envelope
- 1-No. CC105WP Pubic Hair, Pulled Envelope with Inner Envelope
- 1-No. CC106WP Fingernail Scrapings Envelope with Two Inner Envelopes and Two Scrapers
- 1-No. CC107WP Saliva Sample Envelope with Inner Envelope and Specimen Disc
- 1-No. CC108AWP Blood Collection Tube with EDTA for DNA Blood Analysis, 7 ml
- 1-No. CC108WP Blood Collection Tube with EDTA for Whole Blood Sample, 7 ml
- 1-No. CC109WP Microscope Slides and Holder with Oral,

- Rectal and Vaginal Control Labels
- 1-No. CC109WPA Culture Tube, Two Swabs per Tube, with "Oral" Label
- 1-No. CC109WPB Culture Tube, Two Swabs per Tube, with "Rectal" Label
- 1-No. CC109WPC Culture Tube, Two Swabs per Tube, with "Vaginal" Label
- 2-No. EIL021 Evidence "Police Seal" Labels
- 1-No. KCP139 Pair of Tweezers, Plastic, 4 3/4"
- 1-No. KCP161 Fingernail Clippers
- 1-No. KCP206 Biohazard Label, 1" x 1 1/4" Black on Orange



CATALOG NO. CC100WP PRICE: \$14.95

PROSECUTOR'S SUSPECT EVIDENCE COLLECTION KIT

The prosecutor's office in a small Midwestern town consulted with **SIRCHIE**'s sales staff to create an economical, yet precise sexual assault evidence collection kit. This kit is the end result.

No. ISP100 consists of:

- 1-No. 999311 FDA Manufacturer's Insert
- 2-No. EIL021 Evidence "Police Seal" Labels
- 1-No. ISP1001 Envelope, Suspect Pubic Hair Standard
- 1-No. ISP1002 Envelope, Suspect Head Hair Standard
- 1-No. ISP1003 Envelope, Suspect Pubic Hair Combing
- 1-No. ISP1004 Suspect Blood Sample Envelope, with 10 ml Blood Collection Tube
- 1-No. ISP1004A Blood Collection Tube, 7 ml with EDTA for DNA Blood Analysis
- 1-No. ISP1005 Suspect Saliva Sample Envelope
- 1-No. ISP1006 Instruction Card
- 1-No. KCP206 Biohazard Label, 1" x 1 1/4" Black on Orange
- 1-No. KCP223 Box, Polystyrene, Hinged, 7" x 3 1/2" x 1", Factory-Sealed



CATALOG NO. ISP100 PRICE: \$7.95

SEX CRIME INVESTIGATION KITS

DNA MATCHING

Forensic investigation has reached an era of unprecedented accuracy through the research and development of a process known as "DNA fingerprinting." Deoxyribonucleic acid, or DNA, the material of which chromosomes are composed, is contained in every nucleated cell in the body. Just like fingerprints, each individual's DNA is unique. Sometimes referred to as the human genetic blueprint, DNA is the molecule which establishes each person as separate and distinct.

Developed by geneticist Alec Jeffreys at the University of Leicester in Britain, DNA testing yields positive identification information from small samples of blood, semen or other DNA-bearing cells that may be days, months or in some cases, even years old. Whereas present identification techniques serve only to exclude certain suspects, DNA fingerprint functions as a means of positive identification. According to Alec Jeffreys, the odds of two unrelated individuals having the same DNA fingerprint is 10,000,000,000,000 to 1. Lifecodes Corporation, a genetic diagnostic laboratory in Valhalla, New York, concludes that if two genetic make-ups match, the investigator may be 99.9% certain that the specimens are from the same person.

The possibility of confirming an individual's identity by DNA matching makes the need for a DNA blood testing sample imperative. To assist in the collection of liquid or whole blood samples for DNA matching, **SIRCHIE**® places a lavender-topped vacutainer with ethylenediamine tetracetic acid (EDTA) in each sex crimes evidence collection kit. EDTA serves to chelate metal ions so that they can no longer react.



CRIME SCENE DNA EVIDENCE COLLECTION KIT

The possibility of confirming an individual's identity by DNA matching makes the collection of cellular material left at the crime scene mandatory. Each scene presents its own problems and unless the investigator is prepared to collect any and all potential sources of DNA, valuable evidence may be lost. The most frequent forms of forensic evidence available for testing DNA found at the crime scene are: fresh blood, semen, hair roots and clothing stained by physiological fluid.

No. DNA100 consists of:

- 2-No. 660ES1 Evidence Identification Strips, Date/Number Type
- 1-No. 999311 FDA Manufacturer's Insert
- 1-No. DNA1001 DNA100 Information Sheet
- 1-No. DNA1002 Kit Box, 10 1/4" x 6 3/4" x 2 1/4", Factory-Integrity -Sealed

- 5-No. DNA1003 Evidence Collection Envelopes, White, 5" x 7 1/2"
- 5-No. DNA1004 Evidence Collection Envelopes, White, 3.5" x 6.5"
- 1-No. DNA1005 Undergarment Bag, 11 1/2" x 5 7/8" x 3 3/4"
- 1-No. DNA1006 Debris Collection Bag, 18" x 12" x 3"
- 2-No. DNA1007 Outer Clothing Collection Bags, 18" x 12" x 3"
- 1-No. DNA1008 Tape Strip, Red Vinyl, 19"
- 1-No. DNA1009 Distilled Water, 1 oz.
- 4-No. ILSP3008 Evidence Bag Integrity Seals
- 2-No. KCP122 Blood Collection Tubes, 7 ml with EDTA
- 1-No. KCP137 Syringe with Needle, Disposable, 10 cc
- 1-No. KCP139 Pair of Tweezers, Plastic, 4 3/4"
- 5-No. KCP160 Packages of Two Swabs, Sterile, Cotton-Tipped
- 2-No. KCP164 Evidence Seals, Red, "Warning! Police Seal, Do Not Remove"
- 1-No. KCP178 Liquids Absorber Packet
- 1-No. KCP194 Mailer, Styrofoam, Two-Tube
- 5-No. KCP196 Swab Box, Ventilated, No Imprint
- 4-No. KCP206 Biohazard Label, 1" x 1 1/4" Black on Orange
- 5-No. KCP211 Gauze Pads, 12-Ply, 2" x 2"
- 1-No. KCP241 Bag, LocTop, 6" x 9" x 0.004"
- 6-No. SF00761 Latex Powder-Free Gloves, Large, Ambidextrous, .005" thick

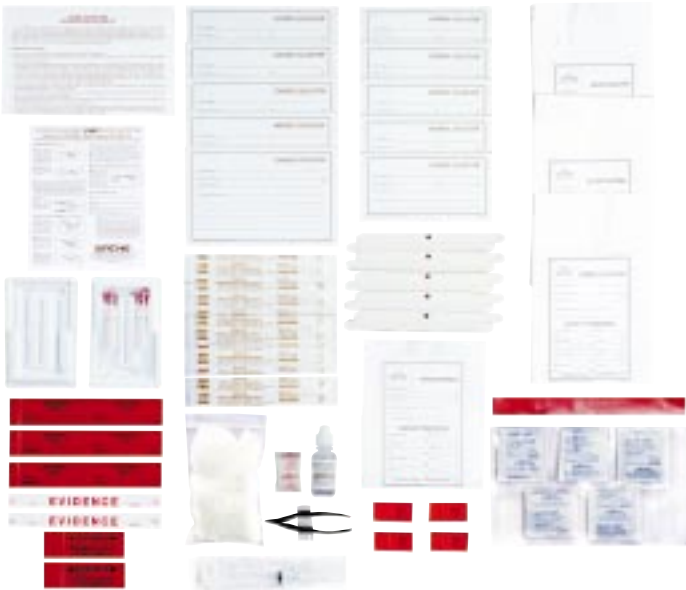

CATALOG NO. DNA100 PRICE: \$19.95

FORENSIC EVIDENCE COLLECTION KITS

SIRCHIE® manufactures specimen collection kits for law enforcement agencies and private laboratories. These kits are designed to standardize the uniform collection and identification of specimens for laboratory analysis. Transportation to the laboratory is accomplished by the utilization of U.S. Postal Service-approved tube mailers. Customized kits are a speciality of **SIRCHIE®** and agencies are encouraged to supply their requirements.

BLOOD ALCOHOL COLLECTION KIT

This is a comprehensive blood alcohol collection kit designed to provide for the safe and efficient collection, handling and mailing of blood specimens. The kit features step-by-step instructions, individually protected blood tubes and a U.S. Postal Service-approved tube mailer.



No. BSC100 consists of:

- 1-No. 999311 FDA Manufacturer's Insert
- 2-No. ABU103 Blood Tube Integrity Seals
- 1-No. BSC1001 Tube Address Label and Seal
- 1-No. BSC1002 Police Officer's Report
- 1-No. BSC1003 Instruction Sheet
- 1-No. BSC1004 Kit Tube, 5" x 2 1/2" dia., Integrity-Sealed
- 1-No. BSC101 Consent Form
- 1-No. BSC102 Blood Collection Report
- 1-No. KCP169 Multisample Needle, 20 ga. x 1 1/2"
- 2-No. KCP176 Blood Collection Tubes, 10 ml with Gray Top
- 1-No. KCP177 Iodine Prep Pad, Medium
- 1-No. KCP178 Liquids Absorber Packet
- 1-No. KCP179 Holder for Multisample Needle and Tube
- 1-No. KCP240 Tourniquet, Latex
- 1-No. KCP241 Bag, LocTop, 6" x 9" x 0.004"

CATALOG NO. BSC100 PRICE: \$6.95

BLOOD ALCOHOL/URINE SPECIMEN COLLECTION KIT

This kit offers the same safety and efficiency of the blood alcohol collection kit with added ability of collecting a urine specimen. It is an ideal kit for departments with multi sample requirements and includes a U.S. Postal Service-approved mailer.

No. BUK100 consists of:

- 1-No. 999311 FDA Manufacturer's Insert
- 2-No. ABU103 Blood Tube Integrity Seals
- 1-No. BUK1001 Tube Address Label and Seal
- 1-No. BUK1002B Police Officer's Report
- 1-No. BUK1003 Instruction Sheet
- 1-No. BUK1004 Urine Specimen Integrity Seals
- 1-No. BUK1005 Kit Tube, 7 5/8" x 2 3/4" dia. Integrity Sealed
- 1-No. BUK1006 Urine Specimen Container, Sterile, 120 ml
- 1-No. BUK101 Consent Form for Blood and Urine
- 1-No. BUK102 Collection Report for Blood and Urine
- 1-No. KCP169 Multisample Needle, 20 ga. x 1 1/2"
- 2-No. KCP176 Blood Collection Tubes, 10 ml with Gray Top
- 1-No. KCP177 Iodine Prep Pad, Medium
- 1-No. KCP178 Liquids Absorber Packet
- 1-No. KCP179 Holder for Multisample Needle and Tube
- 1-No. KCP240 Tourniquet, Latex
- 1-No. KCP241 Bag, LocTop, 6" x 9" x 0.004"



CATALOG NO. BUK100 PRICE: \$8.95



ABOUT PRODUCTION OF EVIDENCE COLLECTION KITS

Evidence collection kits are extremely important in the process of proper and complete collection of forensic evidence. **SIRCHIE**®'s role is to produce the highest quality evidence collection kits available in today's market. With a wide variety of generic kits available and the capability of producing customized kits, **SIRCHIE**® offers each agency or state the freedom to have exactly what they need. By working with the customer and having strict quality-control standards, **SIRCHIE**® is the first choice in forensic evidence collection type kits in the world.

SIRCHIE®'s FDA-approved clean room—as pictured above—is utilized in conjunction with strict quality-control guidelines to assure our customers receive the highest quality kits assembled. Each employee is required to follow a set procedure for preparing him/herself for work in the clean room. Workers are supervised at all times during kit assembly.

SIRCHIE® invites you to give us the opportunity to service your evidence collection kit needs.

For more information about evidence collection kits call 1-800-356-7311.



Production staff assembling an evidence collection kit.

SECTION IX

TABLE OF CONTENTS

Forensic Ultraviolet Lights

Face Shield, UV	242
Goggles, UV	242
Lamp, AC/DC Field and Lab (LW).....	236
Lamp, AC/DC Field and Lab (SW)	239
Lamp, AC/DC Dual Bulb (LW)	238
Lamp, Dual Bulb (LW)	241
Lamp, Dual Bulb Field and Lab (LW)	237
Lamp, Field and Lab (LW)	235
Lamp, Field and Lab (SW)	238
Lamp, Lab UV (SW)	239
Light Source, Dual Bulb UV Lab (LW) ..	237
Light Source, Hi-Power (LW)	235
Light Source, Lab UV (LW)	236
Light Source, TIGER UV Forensic	234
Light Source, AC/DC Tiger (LW & SW) .	241
Light Source, Tiger (LW & SW)	240
Light Source, UV Mini	236
Spectacles, UV	242
Torchlite, Ultraviolet (LW)	242

FORENSIC ULTRAVIOLET LIGHTS

An important thing to know is that ultraviolet (UV) is not a single entity, but is a wide band of wavelengths within the electromagnetic spectrum.

The chief natural source of UV is the sun. In fact, about nine percent of all energy emitted by the sun is UV. Most of which is in the region between 300-400 nm. Artificial sources of UV include incandescent, gas discharge, low pressure mercury, medium pressure mercury metal halide, electrodeless and xenon lamps.

UV light is electromagnetic radiation in the part of the spectrum between x-rays and visible light. It differs from visible light only in that the UV wavelengths are too short to be seen by the human eye. The boundary between visible light and UV is a wavelength of 400 nm (4000 Angstroms). Medical literature divides UV light into three ranges: UV-A (315 nm and higher), UV-B (280-315 nm) and UV-C (280 nm and lower).

An interesting characteristic of UV radiation occurs when it falls upon certain substances known as phosphors, where it causes the phosphors to emit specific radiation. This phenomenon is known as fluorescence. Everyday fluorescent lighting is basically a UV lamp constructed of a type of glass bulb that blocks UV rays. The inside of the bulb is coated with a thin layer of fluorescent material that receives UV generated by the lamp and in return emits a visible light.

One effect of UV energy upon certain substances is a phenomenon that takes place at the atomic level. High-frequency UV photons collide with atoms and part of the photon's energy is transferred to the atoms by boosting electrons to higher energy states.

(continued on page 233)

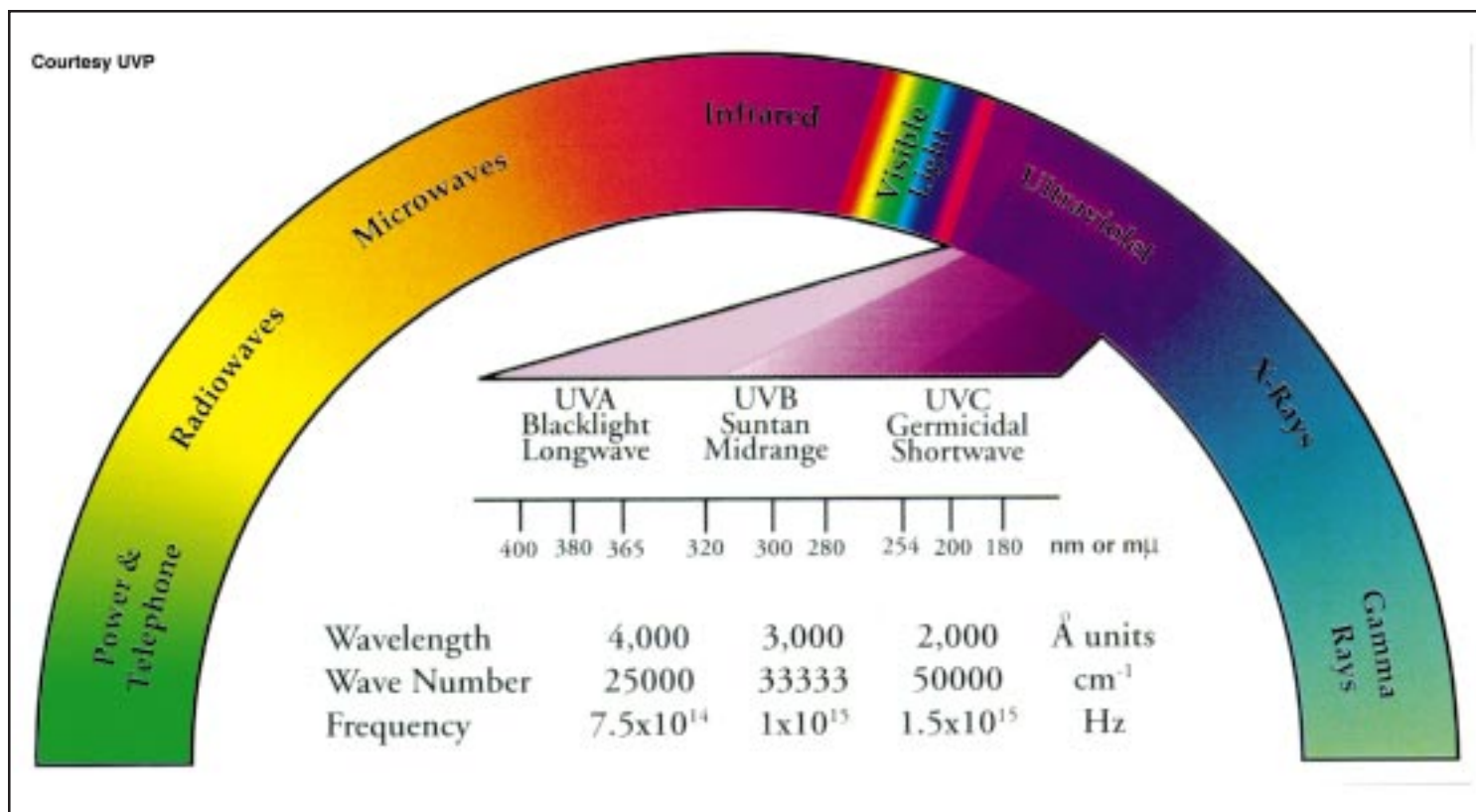

Upon de-excitation, as electrons fall back to lower energy states, energy is released as photons of light. Since only a portion of the incoming photon's energy was transferred to an electron, these emitted photons have less energy than the incoming UV photons, so their wavelengths are longer than the excitation photons. This process is called fluorescence.

In some materials, the fluorescence lingers and disappears, slowing after the UV source is removed. Here, the electron returns slowly to its original energy state, and this delayed fluorescence is called phosphorescence. These unique properties of UV fluorescence and phosphorescence are but two of the many ultraviolet phenomena that make it vital to science and law enforcement.

Ultraviolet (UV) light sources are used at the crime scene and in the laboratory for the preliminary examination and location of physical evidence.

Ultraviolet (UV) light examination of physical evidence traces may yield valuable information toward the solving of many different crimes. Examination of physical evidence under UV light includes just about everything. Some of the more useful items are as follows: physiological fluids, glass and ceramics, petroleum products, fibers, hair, cosmetics, wood and botanical materials, minerals, gems, glues, adhesives, drugs, poisons, plastics, foodstuffs and arson debris.

Ultraviolet (UV) light is essential when utilizing fingerprint enhancement powders and dyes. Silver nitrate, physical developer and DFO development of fingerprints are enhanced with UV light. The use of fluorescent tracer powders, pastes and inks in conjunction with UV light enhance theft detection and security. Imagination is the only limiting factor.



FORENSIC ULTRAVIOLET LIGHTS

TIGER UV FORENSIC ILLUMINATING LIGHT SOURCES



Ultraviolet lights provide illumination at wavelengths that make it possible to visualize many forms of physical evidence that in many cases were undetected by traditional collection methods.

Types of evidence include, but are not limited to, fingerprints, bruises, bite marks, nail scratches, binding marks, blood, semen and other physiological fluid, hairs, fibers, other trace evidence, questioned documents, silver nitrate and physical developer-processed latent prints—and more.

Fluorescence is the emission of electromagnetic radiation mainly in the visible light region resulting from the absorption of incident radiation and persisting only as long as the stimulating radiation is continued.

Ultraviolet light is the indispensable source of stimulating radiation for the scientific study of crime, either at the crime scene or in the laboratory.

about THE TIGER UV ...

This high-intensity longwave (365 nm) ultraviolet light is a necessary tool in all types of investigations. Indispensable for crime scene search teams, arson investigators and UV photography.

No. 790UV Specifications:

- Longwave Filter Cover, Lamp Housing and End Cap Construction: Nylon—Proven thermal and mechanical properties
- Power Source: 115 VAC grounded
- Lamp: Mercury vapor with internal ballast
- Lamp Rating: 150 watts
- Lamp Life: ≈ 5,000 hours
- Filters: 365 nm UV bandpass filter
- Dimensions: 5" diameter × 0.200" thick
- Output: 4,000 μ w/cm² at 15"
- Dimensions: 10 1/4" length × 6 1/16" diameter
- Weight: 3 lbs. 14 oz.
- Outer Case: Aluminum with gloss-black epoxy paint
- Indicator Light: Neon type—diffused
- Power Switch: Heavy-duty rocker switch
- Power Cord: 10 ft.
- Material: Injection-molded copolymer polypropylene
- Dimensions: 20 3/4" × 16 1/2" × 9"
- Weight: 9 lbs.



CATALOG NO. 790UV	TIGER UV LIGHT	PRICE: \$299.00
CATALOG NO. 790UVC	CARRYING CASE	PRICE: \$119.50
CATALOG NO. 790UVB ...	150-WATT REPLACEMENT BULB FOR 790UV	PRICE: \$180.00

HIGH-POWER LONGWAVE LIGHT SOURCE

The design of the No. 752UV light makes it the first choice for examining large volumes of evidence. Double light power reduces eyestrain when searching for minute amounts of evidence. It is built to provide years of trouble-free, maintenance-free service.



No. 752UV Specifications:

- Case Dimensions: 11 7 1/6" high x 3 1/8" wide x 4 1/2" deep
- Construction: 20 gauge (.036" thick) steel, spot-welded housing; painted finish, black with texture
- Weight: 3.1 lbs.
- Power Source: 120VAC power; detachable 7' power cord; 220-240 VAC 50-60Hz optional
- Bulbs: Two; longwave: UV-A black light type (No. F4T5); 4-watt; 365 nm peak wavelength
- Handle: Cast aluminum handle with finger grooves; painted finish, black with texture
- Switch: Push-button starter switch for each lamp



CATALOG NO. 752UV HIGH-POWER LONGWAVE LIGHT SOURCE PRICE: \$99.50

**FIELD AND LAB UV LAMP
(LONGWAVE—HIGH-INTENSITY OPTION)**

The ultraviolet field and lab lamp is practical, powerful and compact. It fits comfortably in the hand. The lamp is battery-powered and features dual power levels for normal and high-intensity viewing. Batteries are not included.



No. 762UV Specifications:

- Case Dimensions: 1 7/8" deep x 1 11/16" wide x 6 7/8" high
- Weight: 11.8 oz. (with batteries)
- Construction: Vinyl-clad aluminum/nickeloid steel
- Peak Wavelength: 365 nm
- Power Source: Four "AA" alkaline batteries, 1.5 volts
- Bulb: Longwave UV-A black light type (No. F4T5), 4-watt
- High-Output Switch: Push-button, momentary
- Power Switch: Push-button, alternate action



CAT NO. 762UV FIELD AND LAB UV LAMP PRICE: \$59.95

**CAT. NO. 6762 REPLACEMENT BULB FOR ALL
4-WATT 365 nm LONGWAVE UV LIGHTS PRICE: \$14.00**

LAB UV LIGHT SOURCE (LONGWAVE)

The UV lab light source is compact, practical and powerful. It fits comfortably in the hand. The unit comes with a durable, heavy-duty cord to supply the power.

Specifications:

- Case Dimensions: 6 13/16" high x 1 11/16" wide x 3 7/16" deep
- Weight: 1.7 lbs.
- Construction: Vinyl-clad aluminum/nickeloid steel
- Peak Wavelength: 365 nm
- Bulb: Longwave UV-A black light type No. F4T5, 4-watt
- Power Switch: Push-button
- Power Source: 110/120V AC



CATALOG NO. 764UV PRICE: \$64.50

AC/DC FIELD AND LAB LAMP (LONGWAVE HIGH-INTENSITY OPTION)

The ultraviolet field and lab lamp is practical, powerful and compact. This model features an AC/DC connector for convenience both in the lab and at the crime scene. The lamp has dual power levels for normal and high-intensity viewing. Batteries are not included.

No. 762ADC Specifications:

- Case Dimensions: 1 7/8" deep x 1 11/16" wide x 6 7/8" high
- Weight: 13 1/2 oz. (with batteries)
- Construction: Vinyl-clad aluminum/nickeloid steel
- Peak Wavelength: 365 nm
- Bulb: Longwave UV-A black light type No. F4T5, 4-watt
- Power Switch: Push-button, alternate action
- High-Output Switch: Push-button, momentary
- Power Source: Four "AA" alkaline batteries, 1.5 volts or 120V AC current



CATALOG NO. 762ADC PRICE: \$69.95

UV MINI LIGHT SOURCE (LONGWAVE)

Use the ultraviolet pocket light to view longwave invisible stains, powders and pastes. The light is ideal for theft detection. A convenient carrying strap is attached to the light source. Batteries are not included.

Specifications:

- Dimensions: 6 1/4" high x 2" wide x 3/4" deep
- Weight: 6 oz. (with batteries)
- Construction: Rugged textured ABS plastic
- Peak Wavelength: 365 nm
- Bulb: Longwave UV-A black light type No. F4T5, 4-watt
- Power Switch: Slide style
- Power Source: Four "AA" alkaline batteries, 1.5 volts



CATALOG NO. CUV100T PRICE: \$29.95

**DUAL BULB FIELD AND LAB UV LAMP
(LONGWAVE HIGH-INTENSITY OPTION)**

The No. 784UV was designed with the idea of giving the operator more power when looking for fluorescence in an area. The dual bulb system doubles light output to enhance the material under observation.



An added feature to this unit is the high-intensity switch. Batteries are not included.



No. 784UV

Specifications:

- Case Dimensions: 6 3/4" high x 3 1/4" wide x 2 5/8" deep
- Weight: 1 lb. 10 oz. (with batteries)

- Construction: Vinyl-clad aluminum/nickeloid steel
- Peak Wavelength: 365 nm
- Bulb: Two longwave UV-A black light type No. F4T5, 4-watt
- Power Switch: Push-button, alternate action
- High-Output Switch: Push-button, momentary
- Power Source: Four "C" alkaline batteries, 1.5 volts

CATALOG NO. 784UV PRICE: \$102.00

**DUAL BULB UV LAB LIGHT SOURCE
(LONGWAVE)**

The lab lamp is practical, powerful and compact. The lamp has a convenient handle which allows for long periods of use. This unit has two 4-watt longwave bulbs which increase the fluorescence of the material being viewed. The unit comes with a heavy-duty durable power supply cord.



No. 786UV Specifications:

- Case Dimensions: 6 3/4" high x 3 1/4" wide x 2 5/8" deep
- Weight: 2 lbs. 1 oz. (unit only)
- Construction: Vinyl-clad aluminum/nickeloid steel
- Peak Wavelength: 365 nm
- Bulb: Two longwave UV-A black light type No. F4T5, 4-watt
- Power Switch: Push-button
- Power Source: 110/120V AC

CATALOG NO. 786UV PRICE: \$105.00

FORENSIC ULTRAVIOLET LIGHTS

AC/DC DUAL BULB FIELD AND LAB UV LAMP (LONGWAVE HIGH-INTENSITY OPTION)

The No. 784ADC was designed with the field investigator in mind. It allows for the use of either 110/120VAC or DC to supply the power for the two longwave bulbs. The dual bulb system doubles light output for fluorescent enhancement. Another feature is the high-intensity switch which increases the viewing capabilities. The unit comes with a durable power cord. Batteries are not included.



No. 784ADC Specifications:

- Case Dimensions: 6 3/4" high x 3 1/4" wide x 2 5/8" deep
- Weight: 1 lb. 10 oz. (with batteries)
- Construction: Vinyl-clad aluminum/nickeloid steel
- Peak Wavelength: 365 nm
- Bulb: Two longwave UV-A black light type No. F4T5, 4-watt
- Power Switch: Push-button, alternate action
- High-Output Switch: Push-button, momentary
- Power Source: Four "C" alkaline batteries, 1.5 volts or 110/120VAC

CAT. NO. 784ADC DUAL BULB FIELD AND LAB UV LAMP PRICE: \$115.00

FIELD AND LAB UV LAMP (SHORTWAVE)

This lamp is powerful, compact, all-metal and battery-powered for field or lab use. Peak filtering ensures high shortwave, UV intensity. Normal and high-intensity switching options are included. Batteries are not included.



No. 772SW Specifications:

- Construction: Vinyl-clad aluminum/nickeloid steel
- Peak Wavelength: 254 nm
- Bulb: Shortwave UV-C germicidal type No. G4T5, 4-watt
- Power Switch: Push-button, alternate action
- High-Output Switch: Push-button, momentary
- Filter: Type U-325C UV Bandpass
- Case Dimensions: 1 7/8" deep x 1 11/16" wide x 6 7/8" high
- Weight: 12 oz. (with batteries)
- Power Source: Four "AA" Alkaline batteries, 1.5 volts



CAT. NO. 772SW FIELD AND LAB UV LAMP, SHORTWAVE PRICE: \$119.95

CAT. NO. 6247 REPLACEMENT BULB FOR ALL 4-WATT 254 nm SHORTWAVE UV LIGHTS PRICE: \$25.75

AC/DC FIELD AND LAB UV LAMP (SHORTWAVE)

This is a powerful and compact, all-metal lamp, AC/DC-powered for field and lab use. It fits comfortably in the hand. Peak filtering ensures high shortwave, UV intensity. Normal and high intensity switching options are included. The unit comes with a durable heavy-duty power supply cord. Batteries are not included.

No. 772ADC Specifications:

- Case Dimensions: 1 7/8" deep x 1 11/16" wide x 6 7/8" high
- Weight: 1 lb. 2 oz. (with batteries)
- Construction: Vinyl-clad aluminum/nickeloid steel
- Peak Wavelength: 254 nm
- Bulb: Shortwave UV-C germicidal type No. G4T5, 4-watt
- Power Switch: Push-button, alternate action
- High-Output Switch: Push-button, momentary
- Filter: Type U-325C UV bandpass
- Power Source: Four "AA" Alkaline batteries, 1.5 volts, 110/120VAC
- Outstanding Feature: Dual power levels



CATALOG NO. 772ADC PRICE: \$129.95

LABORATORY UV LAMP (SHORTWAVE)

This lamp is powerful and compact, all-metal and AC-powered for field or lab use. Peak filtering ensures high shortwave, UV intensity. It fits comfortably in the hand and comes with a heavy-duty power supply cord.

No. 774SW Specifications:

- Construction: Vinyl-clad aluminum/nickeloid steel
- Peak Wavelength: 254 nm
- Bulb: Shortwave UV-C germicidal type No. G4T5, 4-watt
- Power Switch: Push-button, alternate action
- Filter: Type U-325C UV bandpass
- Power Source: 110/120VAC
- Weight: 15.9 oz.
- Case Dimensions: 1 7/8" deep x 1 11/16" wide x 6 7/8" high



CATALOG NO. 774SW PRICE: \$115.00

FORENSIC ULTRAVIOLET LIGHTS

TIGER TWIN UV LIGHT SOURCE (LONGWAVE AND SHORTWAVE)

This unit is compact, battery-powered and ideal for field or lab use. The unit has both longwave and shortwave bulbs for use with all fluorescent materials. An added feature is the high-output switch for additional illumination. Safety lights verify which source is in operation (shortwave or longwave). Batteries are not included. Applications include: physiological fluids detection, questioned document examination, thief detection and trace metal detection.



No. 782UV Specifications:

- Power Source: Four alkaline "C" cells, 1.5 volts
- Case Dimensions: 6 3/4" high x 3 3/8" wide x 2 7/8" deep
- Construction: 0.062" vinyl-clad aluminum, black
- Reflector: 0.040" steel with bright nickel finish
- Shortwave Filter Cover and End Caps: 0.031" steel with brushed nickel finish
- Bulb: Shortwave-UV-C germicidal type (no. G4T5), 4-watt, 254 nm peak wavelength; Longwave-UV-A black light type (no. F4T5), 4-watt, 365 nm peak wavelength
- Shortwave Filter: Type U-325C UV bandpass filter; Dimensions: 3" length x 1 1/2" width x 3/16" to 1/4" thickness
- Weight: 1 lbs. 15 oz. (with batteries)
- Control Panel: Modular, all push-button control panel; power switch—push-button, alternate action; high-output switch—push-button, momentary action; SW/LW selector switch—push-button, alternate action

CATALOG NO. 782UV PRICE: \$169.50

LABORATORY TIGER TWIN UV LIGHT SOURCE (LONGWAVE AND SHORTWAVE)

This is the ideal choice for a single UV light source when situations require longwave and shortwave light. This unit is designed primarily for laboratory use since it is strictly 110/120 VAC and offers dual wavelength capability for a variety of evidence examination assignments. Applications include: physiological fluids detection, questioned document examination, thief detection and trace metal detection.

No. 785UV Specifications:

- Power Source: 110/120V AC
- Case Dimensions: 6 3/16" high x 2 5/8" wide x 3 1/4" deep
- Construction: 0.062" vinyl-clad aluminum, black
- Reflector: 0.040" steel with bright nickel finish
- Shortwave Filter Cover and End Caps: 0.031" steel with brushed nickel finish
- Bulb: Shortwave—UV-C germicidal type (no. G4T5), 4-watt, 254 nm; Longwave—UV-A black light type (no. F4T5), 4-watt, 365 nm peak wavelength
- Shortwave Filter: Type U-325C UV bandpass filter; Dimensions: 3" length x 1 1/2" width x 3/16" to 1/4" thickness
- Weight: 2 lbs. 7 1/2 oz.
- Shortwave Power Switch: Push button
- Longwave Power Switch: Push button



CATALOG NO. 785UV PRICE: \$159.50

**AC/DC TIGER TWIN UV LIGHT SOURCE
(LONGWAVE AND SHORTWAVE)**

This is a dual band, AC/DC powered ultraviolet light source and features rear warning lights (LED) which indicate the band selected—shortwave (254 nm) or longwave (365 nm) for added safety. The No. 782ADC is ideal for the investigator on the move. The unit comes with a heavy-duty power supply cord. Batteries are not included. Applications include: physiological fluids detection, questioned document examination, thief detection and trace metal detection.



No. 782ADC Specifications:

- Power Source: Four alkaline “C” cells (1.5 volts); 110/120VAC
- Case Dimensions: 6 13/16" high x 2 5/8" wide x 3 1/4" deep
- Construction: 0.062" vinyl-clad aluminum, black
- Reflector: 0.040" steel with bright nickel finish
- Shortwave Filter Cover and End Caps: 0.031" steel with brushed nickel finish
- Bulb: Shortwave-UV-C germicidal type (no. G4T5), 4-watt, 254 nm peak wavelength; Longwave-UV-A black light type (no. F4T5), 4-watt, 365 nm peak wavelength
- Shortwave Filter: Type U-325C UV bandpass filter; Dimensions: 3" length x 1 1/2" width x 3/16" to 1/4" thickness
- Weight: 2 lbs. 2 oz. (with batteries)
- Control Panel: Modular, all push-button control panel; power switch—push-button, alternate action; high-output switch—push-button, momentary action; SW/LW selector switch—push-button, alternate action

CATALOG NO. 782ADC PRICE: \$179.50

LONGWAVE DUAL BULB LAMP

This dual bulb lamp provides concentrated longwave (UV) at a fixed location. It is easily set up at entrances or exits of facilities requiring identification of authorized personnel. Use it with pass-out inks, voting integrity dyes and for close identification of any fluorescent materials. The lamp features adjustable height and extension with counterbalanced base.

No. UV741 Specifications:

- Bulb Housing Size: 6 5/8" x 2 3/16" x 1 7/8"
- Jack Knife Arm Blades: 3 sets—3" each
- Base: Cast Steel: Diameter 4 3/4"
- Weight: 4 lbs.
- Power Source: 110/120 VAC
- Bulbs: Two longwave—UV-A black light type no. F4T5, 4-watt, 365 mm peak wavelength
- Switch: Push-button



CATALOG NO. UV741 PRICE: \$141.95

FORENSIC ULTRAVIOLET LIGHTS

ULTRAVIOLET TORCHLITE (LONGWAVE)

Lightweight and portable, the longwave torchlite is excellent for detecting forgeries, false ticket and identification forgeries and exposing fluorescent invisible detection powders and pastes. The No. UVT100 is available in rechargeable NICAD battery or standard "D" cell configuration.

Specifications:

- Size: 11.75" long; 1.68" barrel diameter; 2.32" head diameter
- Weight: 1 lb. 7 oz. (with batteries)
- Construction: ABS cyclac-T black plastic; O-ring or rubber gasket seals at all connection points
- Power Source: Three "D" cell batteries (Eveready alkaline No. E95)
- Indicators: Power ON red LED, recessed
- Lamp: Krypton star high-intensity (PR based); type no. KSA3; 3.7 volts; .7 amps; 3.6 watts; 5.2 spherical candlepower
- UV Filter Specs: Type UG-1 365 nm peak wavelength
- Switching: Slide on/off, push momentary



CATALOG NO.	DESCRIPTION	PRICE
UVT100	RECHARGEABLE NICAD TORCHLITE W/110VAC CHARGER	\$109.95
UVT200	STANDARD "D" CELL TORCHLITE	\$79.95



SPECTACLES

These spectacles protect eyes from harmful shortwave UV radiation emitted from UV and mercury lamps and eliminate the "blue haze" from longwave UV. The top and side shield design provides full UV protection. They are made of polycarbonate and are impact resistant.

CATALOG NO. 797GV	SPECTACLES	PRICE: \$16.00
CATALOG NO. 798GV	GOGGLES	PRICE: \$18.00
CATALOG NO. 799GV	FACE SHIELD	PRICE: \$50.00



GOGGLES

These goggles are constructed of specially formulated plastic which blocks UV transmission over all UV wavelengths and provides optimum contrast in viewing and lessened eye fatigue. A lightweight design with flexible rubber trim fits comfortably on the face—even over prescription glasses.



FACE SHIELD

This face shield is specially designed to protect the entire face from hazardous shortwave UV light while completely eliminating "blue haze" interference normally associated with long wavelengths. Dimensions: 17" dia. x 8 1/4" H.

VISIBLE AND FLUORESCENT INVISIBLE DETECTION MATERIALS

A frequent and serious problem confronting investigators worldwide is that of forming a logical or natural association between a suspect, an object and a location with regard to a particular crime.

Visible and fluorescent invisible powders, pastes, dyes, crayons, ink markers and other tagging devices, in many cases, may serve as invaluable assistants to the investigator establishing the suspect, object and location link. Some of the crimes that lend themselves to visible and fluorescent invisible tagging and tracing are:

- Petty Theft
- Shoplifting
- Coin Box Tampering
- Money Laundering
- Illegal Drug Transactions
- Sexual Crimes
- Repeated Burglaries
- Firearms and Weapons
- Tampered Documents
- Kidnapping
- Food Stamp Fraud
- Industrial Theft
- Trailing
- Industrial Espionage
- Alarm Boxes
- Arson
- Prostitution
- And Many Other Applications

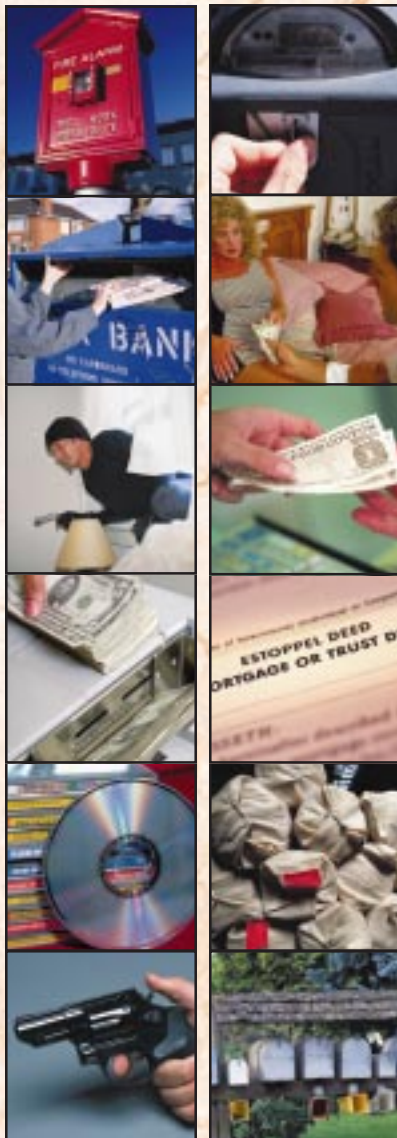

SECTION X TABLE OF CONTENTS

Visible and Fluorescent Invisible Detection Materials

Brush, Regular Powder	254
CLUE SPRAY™	245
Coin Lacquer, Invisible	247
Crayons, Invisible Fluorescent	247
DISCHAPS™, Invisible Marking	248
Fluid, Three-Day Transparent	252
Gloves, Disposable	254
Ink, Invisible Metal Marking	247
Ink, Invisible Skin Marking	248
Ink, Invisible Writing	247
Ink, Tagging	248
Kits, Dual Wavelength	250
Kits, Fluorescent Invisible	249-250
Kits, Visible Stain Detection	253-254
Paste, Dual Wavelength	246
Paste, Fluorescent Invisible	246
Paste, Visible Stain Detection	252
Pen, Invisible Marking	247
Powder, Dual Wavelength	244
Powder, Duo-Stain™ Detection	251
Powder, Fluorescent Invisible	244
Powder, Visible Stain Detection	251
Voting Integrity Systems Application ...	255

FLUORESCENT INVISIBLE DETECTION MATERIALS



FLUORESCENT INVISIBLE DETECTION POWDER

Powders are compounded in various natural colors to blend with diverse object backgrounds to reduce visual detection. Good adhesion properties aid in target-to-hand, body or clothing contact. Apply a light dusting to target object with a soft bristle brush. Packaged in 2 oz. volume containers. Highly fluorescent when exposed to longwave ultraviolet radiation. Use with any **SIRCHIE®** longwave (UV) light source.

CAT. NO.	NATURAL COLOR	FLUORESCENT COLOR	APPLICATION	PRICE
UV201	pale green	brilliant green	currency, paper, clothing, light-colored surfaces	\$20.95
UV202	white	brilliant blue/white	documents, books, white surfaces and clothing	\$20.95
UV203	pale yellow	brilliant yellow	manila papers, envelopes, clothing	\$20.95
UV204	black	brilliant green	foors, telephones, black surfaces	\$20.95
UV205	pale blue	brilliant green	military clothing, rugs, blue surfaces	\$20.95
UV206	salmon	bright orange/red	fire boxes, cardboard, wood, buff surfaces	\$20.95
UV207	gray	brilliant green	cans, silver coins, any gray surface	\$20.95



No. UV213



No. UV213
Longwave
Response



No. UV213
Shortwave
Response



No. UV214



No. UV214
Longwave
Response



No. UV214
Shortwave
Response



No. UV215

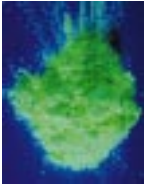

No. UV215
Longwave
Response



No. UV215
Shortwave
Response



No. UV216



No. UV216
Longwave
Response



No. UV216
Shortwave
Response



DUAL WAVELENGTH DETECTION POWDER

These are unique compounds with multiple fluorescent characteristics. Applications are similar to those of the fluorescent invisible detection powders. The singularity of these compounds is that they fluoresce different colors when exposed to longwave and shortwave ultraviolet radiation, establishing beyond a reasonable doubt, target contact. Powders are packaged in 2 oz. volume containers. Recommended light sources: **SIRCHIE®**'s No. 782UV, No. 782ADC and No. 785UV.

CATALOG NO.	NATURAL COLOR	FLUORESCENT COLOR		PRICE
		LONGWAVE	SHORTWAVE	
UV213	PALE YELLOW	YELLOW	GREEN	\$39.95
UV214	WHITE	BLUE/WHITE	GREEN	\$39.95
UV215	PALE GREEN	LIGHT GREEN	DARK GREEN	\$39.95
UV216	BUFF	ORANGE	GREEN	\$39.95

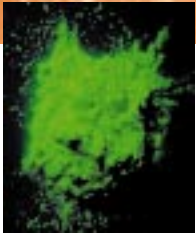

No. UV217
fluorescent
response to
shortwave
radiation only.

LIMITED WAVELENGTH DETECTION POWDER

This powder features the same applications as **SIRCHIE**®'s other fluorescent detection powders, except it is responsive only to shortwave ultraviolet radiation.



CATALOG NO.	NATURAL COLOR	FLUORESCENT COLOR	PRICE
UV217*	IVORY	BRILLIANT GREEN	\$29.95

*254 nm SHORTWAVE ONLY

CLUE SPRAY™ FLUORESCENT INVISIBLE DETECTION POWDER

Powders are packaged in an easy-to-use aerosol spray container so they may be used on porous or non-porous surfaces. These extremely fine particle powders blend easily on almost any object. The light buff color is almost invisible on a black or white-colored surface. They are highly fluorescent when exposed to longwave (UV) radiation. Simply spray on any surface—leaving a very fine film, which, when touched, transfers to skin, clothing or other objects. CLUE SPRAY™ is packaged in 6 oz. regular-size and 4 oz. pocket-size aerosols. Use CLUE SPRAY™ on carpets, tile, wood and just about any walking surface with limited access for tagging and tracing. In outdoor situations it may be washed by rain.



After-Contact Fluorescent Response

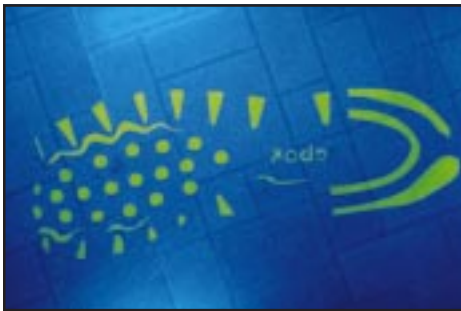

This invisible fluorescent footprint is the result of floor contact with an area treated with CLUE SPRAY™, No. UVA201.



CATALOG NO.	SIZE	NATURAL COLOR	FLUORESCENT COLOR	PRICE
UVA201	6 OZ.	LIGHT BUFF	GREEN	\$26.95
UVA202	6 OZ.	LIGHT BUFF	BLUE/WHITE	\$26.95
UVA203	6 OZ.	LIGHT BUFF	YELLOW	\$26.95
UVA204	6 OZ.	LIGHT BUFF	ORANGE/RED	\$26.95
UVA2011	4 OZ.	LIGHT BUFF	GREEN	\$21.95
UVA2021	4 OZ.	LIGHT BUFF	BLUE/WHITE	\$21.95
UVA2031	4 OZ.	LIGHT BUFF	YELLOW	\$21.95
UVA2041	4 OZ.	LIGHT BUFF	ORANGE/RED	\$21.95

FLUORESCENT INVISIBLE TAGGING SEQUENCE



1. Untreated doorknob

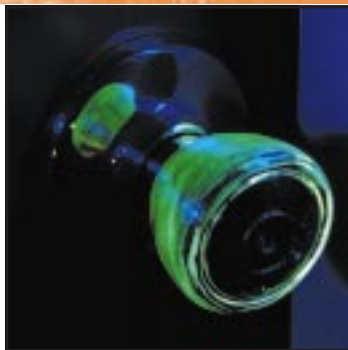

2. Doorknob treated with paste



3. Contact made with doorknob

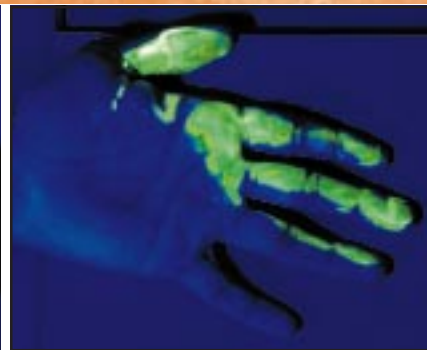

4. Paste viewed under ultraviolet light.

FLUORESCENT INVISIBLE DETECTION PASTE

Detection paste should be used in those situations where powders and powder aerosols are inappropriate due to air circulation, air moisture content or where target object surface condition prohibits its application. Detection paste is suitable for outdoor applications. It is water-resistant and will remain transferrable for prolonged periods of time. It has the consistency of ordinary automobile grease. Apply a thin film on target objects using disposable vinyl or polyethylene gloves. Paste is excellent for use on door knobs, locks, alarm pulls, secure phones and vehicles both indoors and outdoors. Tube packaging allows for controlled application. Use with any **SIRCHIE**® longwave (UV) light.



CATALOG NO.	NATURAL COLOR	FLUORESCENT COLOR	PRICE
UVT208	NEUTRAL PALE GREEN	BRILLIANT GREEN	\$21.95
UVT209	WHITE	BRILLIANT BLUE/WHITE	\$21.95
UVT210	NEUTRAL PALE YELLOW	BRILLIANT YELLOW	\$21.95
UVT211	GRAY	BRILLIANT GREEN	\$21.95
UVT212	BLACK	BRILLIANT GREEN	\$21.95

DUAL WAVELENGTH INVISIBLE DETECTION PASTE

This is a detection paste with multiple fluorescent characteristics. Application and use are identical to those attributed to the fluorescent invisible detection pastes. Any reasonable doubt regarding target contact is eliminated by the unique color distinction when exposed to longwave and shortwave ultraviolet radiation. Recommended light sources: **SIRCHIE**®'s No. 782UV, No. 782ADC and No. 785UV.

CATALOG NO.	NATURAL COLOR	FLUORESCENT COLOR		PRICE
		LONGWAVE	SHORTWAVE	
UVT218	NEUTRAL PALE YELLOW	YELLOW	GREEN	\$39.95



FLUORESCENT INVISIBLE METAL MARKING INK

This is a highly fluorescent, yet invisible ink used primarily for placing identifying marks on all metals. The ink is fast-drying, permanent and may be applied with a cotton swab or fine-pointed brush. The ink fluoresces a brilliant blue/white when exposed to either longwave (UV) or shortwave (UV) radiation.

CATALOG NO. UV731 INK, 2 OZ. BOTTLE PRICE: \$20.95
CATALOG NO. UV731P INK, 16 OZ. BOTTLE PRICE: \$99.50



Scissors treated with No. UV731, viewed in natural light.



Scissors treated with No. UV731, viewed under ultraviolet light.



This is a coin treated with invisible coin lacquer, viewed under ultraviolet light.



FLUORESCENT INVISIBLE COIN LACQUER

This is a frost-colored lacquer that rapidly dries clear, leaving an invisible but highly fluorescent tag. It is used primarily on coins involving vending machines and parking meters in tagging/tracing situations. Apply with a swab or brush. It fluoresces a brilliant green when exposed to either longwave (UV) or shortwave (UV) radiation.

CATALOG NO. UV732 LACQUER, 2 OZ. JAR PRICE: \$22.95
CATALOG NO. UV732P LACQUER, 16 OZ. JAR ... PRICE: \$103.50

FLUORESCENT INVISIBLE WRITING INK

This is an outstanding ink for permanently marking legal papers, stocks and bonds, currency and other documents with completely invisible tagging and identification marks. Use with a cotton swab, bladder-type fountain pen or even a toothpick for writing. Markings are highly fluorescent when exposed to longwave (UV) or shortwave (UV) radiation.

CATALOG NO. UV734 INK, 2 OZ. PRICE: \$19.95
CATALOG NO. UV734P INK, 16 OZ. PRICE: \$49.50



A mark made with the invisible marking pen is viewed under an ultraviolet light.

FLUORESCENT INVISIBLE MARKING PEN

This is an all-purpose pen that may be used for marking just about any type of material with an invisible, permanent, highly fluorescent tag for identification and tracing. It permanently marks paper, cardboard, cloth, wood and any other porous materials. Marks are made easily and may be removed from glass, plastics, metals and any other non-porous materials. Markings fluoresce a brilliant blue/white when exposed to longwave (UV) or shortwave (UV) radiation.

CATALOG NO. UV700 PRICE: \$19.95

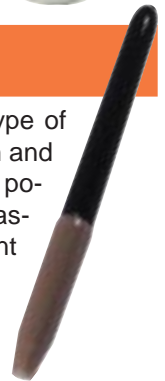

INVISIBLE FLUORESCENT CRAYONS

Crayons may be used effectively to mark currency, paper and cardboard products, clothing, plastic products and other porous or non-porous materials for tagging and tracing purposes. Markings are highly fluorescent when exposed to longwave (UV) or shortwave (UV) radiation.



Marking currency with an invisible fluorescent crayon is easy.

CATALOG NO.	NATURAL COLOR	FLUORESCENT COLOR	PRICE
UV737	IVORY WHITE	BLUE/WHITE	\$3.95
UV738	PALE YELLOW	YELLOW	\$3.95
UV739	PALE GREEN	GREEN	\$3.95

FLUORESCENT INVISIBLE DETECTION MATERIALS

FLUORESCENT INVISIBLE SKIN MARKING INK (PASS IN-PASS OUT)

This is a highly fluorescent invisible skin marking ink when applied (swabbed, dabbed or stamped) on the skin. It dries immediately with no visible trace. When exposed to longwave (UV) radiation, it fluoresces a brilliant blue/white. The combination of fluorescent invisible skin ink and ultraviolet light is one of the easiest methods of controlling access or egress from facilities such as prisons, detention houses and other control areas. Identifying dates, times and other symbols are easily changed with a combination of stamps and stamp pads.



Invisible skin marking ink is invisible in natural light and highly fluorescent when exposed to ultraviolet light.

CATALOG NO.	DESCRIPTION	PRICE
UV741	LONGWAVE (UV) DUAL BULB LAMP, 110/120VAC	\$141.95
UV742	UNINKED STAMP PAD	\$5.00
UV743	FLUORESCENT SKIN MARKING INK, 16 OZ.	\$21.95
UV743L	FLUORESCENT SKIN MARKING INK, 32 OZ.	\$29.50



FLUORESCENT INVISIBLE SKIN MARKING KIT

This is a complete, portable kit containing the necessary equipment to control access or egress at any facility having 110/120VAC available.

No. UV793 consists of:

- 1-No. UV741 Longwave (UV) Dual Bulb Lamp, 110/120 VAC
- 1-No. UV743 Fluorescent Skin Marking Ink, 16 oz.
- 1-No. UV742 Uninked Stamp Pad
- 1-No. UV744 Copolymer Carrying Case

Dimensions: 16 3/8" x 8 5/8" x 7"; Weight: 7 lbs. 8 oz.

CATALOG NO. UV793	PRICE: \$169.50
--------------------------------	------------------------

ALL-SURFACE, FLUORESCENT INVISIBLE TAGGING INK COMBINATION

With this refillable marking pen, invisible tagging and identification of any surface is possible. Use it on glass, all metals, rubber, vinyl, ceramic, cloth (natural or man-made fibers) cardboard and paper. Markings fluoresce a brilliant blue-white and dry on any surface very quickly.

No. UVC100 consists of:

- 1-No. UV999 Tagging Ink, 16 oz.
- 1-No. UV991 Refillable Aluminum Marking Pen

CATALOG NO. UVC100	PRICE: \$49.95
---------------------------------	-----------------------



DISCHAPS™ FLUORESCENT INVISIBLE MARKING INK

These are one-time use, disposable tagging applicators. The DISCHAPS™ assembly consists of ampoules filled with fluorescent invisible marking liquids and capillary cotton swab heads. Crush the ampoule in its jacket, remove the integrity cap and apply to the object to be tagged for tracing or security. Recap when completed and dispose of the entire assembly. Markings are highly fluorescent when exposed to longwave (UV) or shortwave (UV) radiation.

CATALOG NO.	DESCRIPTION	PRICE
UFM100	INVISIBLE METAL MARKING INK	\$23.95/PACK OF 6
UFM200	INVISIBLE COIN LACQUER	\$23.95/PACK OF 6
UFM300	INVISIBLE SKIN MARKING INK	\$23.95/PACK OF 6
UFM400	INVISIBLE WRITING INK	\$23.95/PACK OF 6



PATROL CAR DETECTION KIT

This is a useful kit for those departments experiencing a high incidence of petty theft in residential and commercial institutions. Verification of suspects may be easily established with the contents of this kit. A battery-operated longwave (UV) light is included.



No. UV100 consists of:

- 1-No. CUV100T Mini Light, Longwave, DC only
- 4-No. KCP230 AA-Cell Batteries, Alkaline
- 1-No. UVA2011 CLUE SPRAY™
- 1-No. UV737 Invisible Fluorescent Crayon

- 1-No. UV700 Fluorescent Invisible Marking Pen
- 1-No. SF00771 Disposable Latex Glove Pair
- 1-No. UV1001 Molded Plastic Carrying Case with Inserts
Dimensions: 12 1/8" x 7 1/4" x 4 1/2"
Weight: 1 lb. 12 oz.

CATALOG NO. UV100 PRICE: \$69.95

FLUORESCENT INVISIBLE TAGGING KIT

This kit is used primarily to tag and identify objects for tracking purposes. Components permit the marking of all types of materials, such as paper, metal, cloth and plastic. Multiple, invisible tagging is possible with liquids and crayons. A battery-operated, longwave (UV) light is included for field portability.



No. UV200 consists of:

- 1-No. CUV100T-UV Mini Light, Longwave, DC only
- 4-No. KCP230 AA-Cell Batteries, Alkaline
- 2-No. 118L Regular Powder Brushes
- 1-No. UV7311 Invisible Metal Marking Ink, 1 oz. bottle
- 1-No. UV7321 Invisible Coin Lacquer, 1 oz. bottle
- 1-No. UV737 Invisible Fluorescent Crayon

- 1-No. UV738 Invisible Fluorescent Crayon
- 1-No. UV739 Invisible Fluorescent Crayon
- 1-No. UV700 Fluorescent Invisible Marking Pen
- 1-No. UV2001 Molded Plastic Carrying Case with Inserts
Dimensions: 12 1/8" x 7 1/4" x 4 1/2"
Weight: 2 lbs.

CATALOG NO. UV200 PRICE: \$59.50

FLUORESCENT INVISIBLE SNARE KIT

Positively identify a suspect or suspects with the components in this kit. A selection of detection powders and tagging paste, as well as various marking devices are included. A battery-operated longwave (UV) light is included for field portability.



No. UV300 consists of:

- 1-No. UV201 Fluorescent Invisible Detection Powder, 2 oz. Jar
- 1-No. UV203 Fluorescent Invisible Detection Powder, 2 oz. Jar
- 1-No. UV207 Fluorescent Invisible Detection Powder, 2 oz. Jar
- 1-No. UVT208 Fluorescent Invisible Detection Paste, 2 oz. Tube
- 1-No. UV7351 Invisible Ink, 1 oz. Bottle
- 1-No. UV7311 Invisible Metal Marking Ink, 1 oz. bottle
- 1-No. UV7321 Invisible Coin Lacquer, 1 oz. bottle

- 1-No. CUV100T-UV Mini Light, Longwave, DC only
- 4-No. KCP230 AA-Cell Batteries, Alkaline
- 3-No. 118L Regular Powder Brushes
- 1-No. UV737 Invisible Fluorescent Crayon
- 1-No. UV739 Invisible Fluorescent Crayon
- 6-No. KCP210 Cotton-Tipped Applicator Swabs
- 1-No. UV3001 Molded Plastic Carrying Case with Inserts
Dimensions: 14 3/8" x 8" x 7"
Weight: 3 lbs. 10 oz.

CATALOG NO. UV300 PRICE: \$119.95

FLUORESCENT INVISIBLE DETECTION MATERIALS

APPREHENDER SPECIAL KIT

This kit consists of a variety of fluorescent invisible detection taggants and tracing materials including CLUE SPRAY™. Whether the requirement is to tag currency for a narcotics buy or to spray a floor to identify a security breach—the components of this kit will meet those needs. A battery-operated longwave (UV) light is included for field use.

No. UV400 consists of:

- 1- No. UV201 Fluorescent Invisible Detection Powder, 2 oz. Jar
 - 1- No. UV202 Fluorescent Invisible Detection Powder, 2 oz. Jar
 - 1- No. UV204 Fluorescent Invisible Detection Powder, 2 oz. Jar
 - 1- No. UV207 Fluorescent Invisible Detection Powder, 2 oz. Jar
 - 1- No. UVT208 Fluorescent Invisible Detection Paste, 2 oz. Tube
 - 1- No. UVT211 Fluorescent Invisible Detection Paste, 2 oz. Tube
 - 1- No. UVA201 CLUE SPRAY™
 - 1- No. UV737 Invisible Fluorescent Crayon
 - 1- No. UV739 Invisible Fluorescent Crayon
 - 1- No. CUV100T-UV Mini Light, Longwave, DC only
 - 4- No. KCP230 AA-Cell Batteries, Alkaline
 - 4- No. 118L Regular Powder Brushes
 - 1- No. UV700 Fluorescent Invisible Marking Pen
 - 12- No. KCP210 Cotton-Tipped Applicator Swabs
 - 1- No. UV4001 Carrying Case, Vinyl Leatherette-Covered with Steel Hardware
- Dimensions: 13 1/2" x 9 3/4" x 5"
Weight: 6 lbs. 5 oz.



CATALOG NO. UV400 PRICE: \$199.50

DUAL WAVELENGTH POSITIVE DETECTION KIT

This kit is without equal. It offers dual wavelength tagging powders and paste along with a selection of **SIRCHIE®**'s standard longwave fluorescent detection products. Utilization of **SIRCHIE®**'s dual wavelength fluorescent materials and their unique color response to longwave and shortwave (UV) radiation establishes, beyond reasonable doubt, target contact. Inclusion of the tiger twin longwave (UV) and shortwave (UV) light source adds portability for field use.

No. UV500 consists of:

- 1- No. UVA201 CLUE SPRAY™
 - 4- No. 118L Regular Powder Brushes
 - 1- No. UV213 Dual Wavelength UV Powder, 2 oz. Jar
 - 1- No. UV214 Dual Wavelength UV Powder, 2 oz. Jar
 - 1- No. UV215 Dual Wavelength UV Powder, 2 oz. Jar
 - 1- No. UV216 Dual Wavelength UV Powder, 2 oz. Jar
 - 1- No. UV737 Invisible Fluorescent Crayon
 - 1- No. UV739 Invisible Fluorescent Crayon
 - 1- No. UVT208 Fluorescent Invisible Detection Paste, 2 oz. Tube
 - 1- No. UVT211 Fluorescent Invisible Detection Paste, 2 oz. Tube
 - 1- No. UVT218 Dual Fluorescent Invisible Detection Paste, 2 oz. Tube
 - 1- No. UV731 Invisible Metal Marking Ink, 2 oz. Bottle
 - 1- No. UV732 Invisible Coin Lacquer, 2 oz. Bottle
 - 1- No. 782UV Tiger Twin Dual Longwave/Shortwave Ultraviolet Light Source, DC
 - 4- No. KCP233 C-Cell Batteries, Alkaline
 - 20- No. KCP210 Cotton-Tipped Applicator Swabs
 - 1- No. UV700 Fluorescent Invisible Marking Pen
 - 1- No. UV5001 Carrying Case, Molded Copolymer, with Latches
- Dimensions: 17 1/2" x 10 1/4" x 8 1/2"
Weight: 8 lbs. 4 oz.

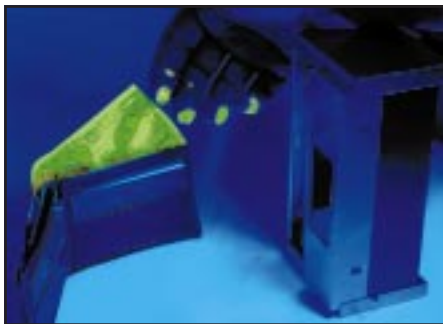

Ultraviolet light exposure



CATALOG NO. UV500 PRICE: \$296.75

about **THESE PRODUCTS ...**

Tagging materials, compounded of aqueous dyes, are used primarily in those situations where there is no reasonable assumption of a suspect.

Major considerations before applying visible stain detection materials are:

1. The object to be treated, if POROUS, will be permanently discolored and probably unserviceable. Materials such as paper, cardboard, textile products and thermoplastics fall into this category.
2. NON-POROUS materials such as steel, glass, thermoset plastics, and painted metal or wood surfaces usually may be restored or cleaned when required.
3. Powders should not be used on objects that are subject to air flow as airborne stain detection particles could contaminate large areas. In situations where air flow is possible, only VISIBLE STAIN PASTE should be used.
4. When in doubt, use only non-destructive fluorescent invisible detection materials.

Powder-treated currency



Contact result after exposure to moisture



VISIBLE STAIN DETECTION POWDERS

These powders should only be used indoors, subject to the statements regarding their use in the discussion above. A visible stain powder should be selected based on its natural color blending with the color of the target object. It should be carefully dusted on the object with a soft applicator brush. When contact with the object is made, a transfer occurs. When the transferred powder contacts moisture, such as perspiration, facial fluids or water, the powder goes into solution and a resulting vivid color appears.

CATALOG NO.	NATURAL COLOR	STAIN COLOR	PRICE
VS301	GREEN	PURPLE	\$20.95
VS302	MAHOGANY	BLUE	\$20.95
VS303	BROWN	RED	\$20.95
VS304	SILVER	PURPLE	\$20.95
VS305	BLACK	PURPLE	\$20.95
VS306	COPPER	ORANGE	\$20.95
VS307	GREEN	AQUA GREEN	\$20.95

DUO-STAIN™ VISIBLE DETECTION POWDER

The application of this powder is the same as outlined for visible stain detection powders, and the same restrictions apply. The uniqueness of this powder is its dual color development. Initial contact with the target object and the resultant combination with body moisture gives a vivid blue color. A secondary color of dark brown spots will emerge after exposure to natural light.

CATALOG NO. DS100 DUO-STAIN™ POWDER, 2 OZ. PRICE: \$29.50



VISIBLE STAIN THIEF DETECTION MA



Untreated doorknob



Doorknob treated with visible stain detection paste

Contact result after exposure to moisture



VISIBLE STAIN DETECTION PASTE

Detection pastes may be used indoors or outdoors without regard to air circulation. Consideration for rain or high moisture and air content should be addressed before applying pastes to a target object since the dye in the compound is water soluble (see page 251). Simply squeeze a small amount of paste on the target object in the area that a hand would have to touch, and spread a thin, even coat that will blend with the object's color. ALWAYS protect hands with disposable, vinyl or polyethylene gloves when performing this task. If the target object is touched, transfer will occur and the aqueous dye in the paste will go into solution with perspiration, facial fluids or water with a resulting vivid color appearing.



CATALOG NO.	NATURAL COLOR	STAIN COLOR	PRICE
VST308	MAHOGANY	BLUE	\$21.95
VST309	BROWN	RED	\$21.95
VST310	GREEN	PURPLE	\$21.95
VST311	BLACK	PURPLE	\$21.95
VST312	SILVER	PURPLE	\$21.95
VST313	COPPER	ORANGE	\$21.95
VST314	GREEN	AQUA GREEN	\$21.95

THREE DAY TRANSPARENT DETECTION FLUID

This is a highly viscous, transparent detection fluid with the same use restrictions applying as those regarding visible detection powders and pastes. An additional restriction is that this fluid should never be applied to unplated or unpainted metals. The detection fluid should be applied to a target object with a cotton swab. Disposable vinyl or polyethylene gloves should be worn when performing this function. When contact is made with the tagged object, the combination of body salts and natural light develops a brown to black color on the skin that cannot be removed by washing, and it will remain visible for approximately three days.

CATALOG NO. VS615 DETECTION FLUID, 1/2 OZ. PRICE: \$29.95



VISIBLE STAIN THIEF DETECTION MATERIALS

MINI VISIBLE STAIN DETECTION KIT

This kit contains a visible stain powder suitable for tagging currency and a visible stain paste to blend with dark-colored surfaces. Suitable objects for tagging should have colors similar to either the powder or paste.

No. VS100 consists of:

- 1- No. VST308 Visible Stain Paste, 2 oz. Tube
- 1- No. VS301 Visible Stain Powder, 2 oz. Jar
- 1- No. 118L Regular Powder Brush
- 12- No. KCP210 Cotton-Tipped Applicator Swabs
- 1- No. SF00771 Disposable Latex Glove Pair



- 1- No. VS1001 Black Molded Copolymer Carrying Case
Dimensions: 8 1/2" x 7 3/4" x 3 5/8"

CATALOG NO. VS100 PRICE: \$39.95

REGULAR VISIBLE STAIN DETECTION KIT

This kit is a step up from the mini visible stain detection kit, offering an increase in both visible powder and paste selections. A wider choice of target objects may be selected with the increased natural color selection.

No. VS200 consists of:

- 1- No. VS301 Visible Stain Powder, 2 oz. Jar
- 1- No. VS304 Visible Stain Powder, 2 oz. Jar
- 1- No. VST309 Visible Stain Paste, 2 oz. Tube
- 1- No. VST310 Visible Stain Paste, 2 oz. Tube
- 2- No. 118L Regular Powder Brushes
- 10- No. KCP210 Cotton-Tipped Applicator Swabs
- 1- No. SF00771 Disposable Latex Glove Pair



- 1- No. VS2001 Copolymer Carrying Case
Dimensions: 12 1/8" x 7 1/4" x 5 1/2"
Weight: 2 lbs. 4 oz.

CATALOG NO. VS200 PRICE: \$59.50

MASTER VISIBLE STAIN DETECTION KIT

This is a complete master visible stain tagging kit. Components include a comprehensive selection of visible stain powder and pastes including **SIRCHIE**'s three day transparent detection fluid. All the necessary applicator brushes and swabs are included. It is an excellent choice for public and private institutions.

No. VS300 consists of:

- 1- No. VS301 Visible Stain Powder, 2 oz. Jar
- 1- No. VS302 Visible Stain Powder, 2 oz. Jar
- 1- No. VS303 Visible Stain Powder, 2 oz. Jar
- 1- No. VS304 Visible Stain Powder, 2 oz. Jar
- 1- No. VS305 Visible Stain Powder, 2 oz. Jar
- 1- No. VS306 Visible Stain Powder, 2 oz. Jar
- 1- No. VST308 Visible Stain Paste, 2 oz. Tube
- 1- No. VST309 Visible Stain Paste, 2 oz. Tube
- 1- No. VST310 Visible Stain Paste, 2 oz. Tube
- 1- No. VST311 Visible Stain Paste, 2 oz. Tube



- 1- No. DS100 Duo-Stain™ Detection Powder, 2 oz. Jar
- 1- No. VS615 Three Day Transparent Detection Fluid, 1/2 oz. Jar
- 6- No. 118L Regular Powder Brushes
- 12- No. KCP210 Cotton-Tipped Applicator Swabs
- 1- No. SF00771 Disposable Latex Glove Pair
- 1- No. VS3001 Carrying Case, Vinyl Leatherette-Covered with Steel Hardware
Dimensions: 19 1/4" x 10" x 6"
Weight: 7 lbs. 10 oz.

CATALOG NO. VS300 PRICE: \$196.25

THIEF DETECTION MATERIALS

ALL-PURPOSE DETECTION KIT

Fluorescent invisible and visible powders, pastes, dyes, crayons, ink markers and other tagging devices can serve as invaluable assistants to an investigator in establishing a suspect, object and location link. The **SIRCHIE®** all-purpose detection kit components equip an investigator with the tools necessary to resolve crimes related to property theft. A battery-operated longwave (UV) light is included for field use.



No. UVS900 consists of:

- 1- No. VS301 Visible Stain Powder, 2 oz. Jar
 - 1- No. VS302 Visible Stain Powder, 2 oz. Jar
 - 1- No. VS304 Visible Stain Powder, 2 oz. Jar
 - 1- No. VS306 Visible Stain Powder, 2 oz. Jar
 - 1- No. VST309 Visible Stain Paste, 2 oz. Tube
 - 1- No. VS615 Three Day Transparent Detection Fluid, 1/2 oz. Jar
 - 1- No. UV201 Fluorescent Invisible Detection Powder, 2 oz. Jar
 - 1- No. UV202 Fluorescent Invisible Detection Powder, 2 oz. Jar
 - 1- No. UV203 Fluorescent Invisible Detection Powder, 2 oz. Jar
 - 1- No. UVT208 Fluorescent Invisible Detection Paste, 2 oz. Tube
 - 1- No. UVT209 Fluorescent Invisible Detection Paste, 2 oz. Tube
 - 1- No. UVT211 Fluorescent Invisible Detection Paste, 2 oz. Tube
 - 1- No. UVA201 CLUE SPRAY™, 6 oz. Can
 - 1- No. UV739 Invisible Fluorescent Crayon
 - 1- No. UV700 UV Fluorescent Invisible Marking Pen
 - 1- No. CUV100T UV Mini Light, Longwave, DC only
 - 4- No. KCP230 AA-Cell Batteries, Alkaline
 - 4- No. 118L Regular Powder Brushes
 - 20- No. KCP210 Cotton-Tipped Applicator Swabs
 - 1- No. SF00771 Disposable Latex Glove Pair
 - 1- No. UVS9001 Carrying Case, Vinyl Leatherette-Covered with Steel Hardware
- Dimensions: 15 3/8" x 12 1/2" x 5 1/4"
Weight: 8 lbs. 2 oz.

CATALOG NO. UVS900 PRICE: \$296.50

THEFT DETECTION ACCESSORIES

SEARCH® REGULAR POWDER BRUSH

This is a general purpose brush made of high-quality camel hair. The fine quality of the bristles permit the dusting of target objects with a very fine coat of either fluorescent invisible or visible detection powder. The brush is complete with a protective container and cap. Bristle length: 1 1/2". Overall length: 5 1/4".



CATALOG NO. 118L PRICE: \$4.25

LATEX GLOVES

These are durable, natural, ambidextrous latex gloves, available in powdered and powder-free in three different thicknesses for added degrees of protection. All gloves are large.

CATALOG NO.	DESCRIPTION	DIMENSIONS	PRICE
SF0076	LATEX POWDER-FREE	10" x .005"	\$11.95/100
SF0077	LATEX, POWDERED	10" x .005"	\$11.95/100
SF0079	LATEX, POWDERED, BLUE	12" x .010"	\$18.25/50
SF0080	LATEX, POWDER-FREE	12" x .014"	\$26.95/50

VISA VOTING INTEGRITY SYSTEMS APPLICATION



SIRCHIE® Finger Print Laboratories has been involved in assisting election commissions with their voter integrity problems for more than 20 years. **SIRCHIE®**'s participation has ranged from pure consultation to actual on-site supervision. **SIRCHIE®** is familiar with the intricacies of the election commissions and the pressures they face.

Basically, there are two methods that may be utilized. One uses a visible dye solution which is easily applied, readily seen and resists removal with soap and water and common solvents for up to 48 hours. The other method employs an invisible solution which is visible only under ultraviolet illumination and, therefore, is extremely hard to remove (it is difficult to remove what can't be seen). The invisible solution supplied to one country successfully resisted removal by test washings with pumice soap for a period in excess of 10 days. The visible and invisible solutions may be combined for additional security. To further enhance each solution's security capabilities, additives may be introduced that will cause the finger tissue to be stained a contrasting brown/black when the visible stain (red or purple) is attempted to be removed. This black stain is particularly noticeable on and around the fingernail and cuticle.

In the past, the standard method for applying both of the solutions was to dip one or more fingers into the solution up to the first joint. This ensures that the fingernail and surrounding tissue are coated. However, due to the international concern over infectious and communicable disease, especially AIDS, **SIRCHIE®** now recommends that the voting fraud solution be dispensed from a dropper bottle that allows the election official to drop three drops of the marking ink onto the fingernail area of one of the voter's fingers without either party coming into physical contact.

The most efficient way to supply the solution is in a 60 ml plastic bottle, with a control drip plug and a screw-on lid. Each 60 ml bottle of solution will process between 375-400 voters, assuming three drops per voter. The plastic bottles are durable, easily transported and with the screw-on lid, ensure safe storage for periods up to 12 months. **SIRCHIE®** can also supply voting fraud solutions in bulk containers.

The visible and invisible solutions have been formulated to provide the highest reaction without compromising the health and safety considerations of the electorate. **SIRCHIE®** has been careful to formulate solutions that provide sufficient coverage to meet the needs of the election, but will not permanently deface or damage skin tissue. Safety material date information is available on each solution. A video production "Voting Integrity Systems" is available. Specify NSTC, SECAM or PAL when requesting.

SIRCHIE® has provided integrity systems for many nations around the world. Information regarding the methods used and the countries serviced is available on a formal government request only.

Contact:

SIRCHIE® Finger Print Laboratories
Youngsville

Attention: Director, Voting Integrity Systems

**SECTION XI
TABLE OF CONTENTS**

**Forensic Evidence
Equipment**

Atomic Absorption Analysis 257-260

Blood Testing 264-265

Drug Testing 266-267B

Explosives Residue Testing 259

Firearms Residue Collection 257-260

Handwriting Analysis 268-271

Infrared Viewer 270

Luminol 265

Narcotics Analysis Kits 266-267B

Physiological Fluid Testing 263-265

Portable Police Laboratory 272

Serial Number Restoration 261-262

Questioned Document Analysis 268-271

Questioned Document Kit, Master 271

Seminal Fluid Testing 263

Trace Metal Detection 259

FORENSIC EVIDENCE EQUIPMENT

Reagents and equipment for:

- Presumptive identification of drugs ...
- Preliminary verification of blood and semen ...
- Restoration of erased or destroyed serial numbers and other identifying marks ...
- Firearms discharge residue collection and gunpowder particle detection ...
- Trace metal contact detection ...
- Questioned document identification and indented and erased ink detection ...
- Explosive nitrite residue screening.

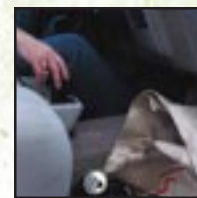

PRIMER RESIDUE TRACES

When a weapon is fired, gun powder residues are propelled toward the target. Primer and gunpowder residues are blown back in the direction of the shooter. In most cases, trace amounts of these residues are deposited on the shooter's firing hand. The detection of these trace residues can give valuable information regarding whether or not a particular individual has recently fired a weapon. The collection of primer residues deposited on the hand of the shooter—normally on the thumb web and the back of the hand holding the weapon is accomplished by swabbing those areas with plastic cotton tips that have been moistened with a 5 percent nitric acid solution. Determining whether or not a particular person has fired a weapon is normally accomplished by measuring the amount of barium and antimony on the suspect's hands. Atomic absorption spectrophotometry analysis has proven to be very successful in identifying these trace residues.



ATOMIC ABSORPTION ANALYSIS

Atomic absorption analysis is considered to be the most sensitive, most effective method for the detection of firearm discharge residue on the skin or clothing of a suspect. The AAA process has demonstrated its suitability as an investigative aid for nearly a decade and has been accepted in federal and state courts as conclusive evidence in numerous cases.

The AAA process detects the presence of barium, antimony, copper and lead. Barium and antimony are present in the primers of most United States-made and some European brands of ammunition, while copper and lead particles originate from cartridge cases and projectiles. Upon detonation of a cartridge, these elements are deposited on the shooter's hands. The No. AAA100 kits are used to swab the suspect's hands. The samples taken are then submitted for laboratory analysis.

Due to the extreme sensitivity of atomic absorption analysis, the swabs, preservation tubes, nitric acid solution and container must be free from contamination.

SIRCHIE® has developed this kit to fulfill this requirement. All components are handled under controlled conditions to ensure the absolute minimum in contamination.



Swabbing a suspect's hand for gunshot residue collection

Summary of results of the **SIRCHIE**® No. AAA100 kit (testing performed by the forensic staff of the national office laboratory).

Item	Micrograms Barium	Micrograms Antimony
5% HNO (6 drops)	0.00	0.00
*Cotton Swab	0.02	0.00

*Average of five analyses

Laboratory conclusion: "from the above values the materials are quite pure and will be ideal for use in production-run kits."

Contents of individual test kit:

- 1-No. KCP123 Polyethylene Dispenser, 5% Nitric Acid with Controlled Flow Applicator and Molded Protective Cap, 3 ml
- 6-No. AAA1001-AAA1006 Vials, Open End, Contaminant-Free with 12 mm Polypropylene Closures, with Polyethylene Specimen Swabs, 2 1/2" Long
- 1-No. EIL021 Police Seal Warning Label
- 1-No. SF00761 Latex, Powder Free Glove Pair
- 1-No. KCP120 Case, Molded Styrene
Dimensions: 4 5/8" x 3 1/2" x 7/8"



CATALOG NO. AAA100 CONSISTS OF 10 KITS IN A MASTER BOX \$59.95

FIREARMS DISCHARGE RESIDUE COLLECTION



Collecting residue for scanning electron microscopy

PRIMER RESIDUE COLLECTION KIT

for analysis by ...

(SEM) SCANNING ELECTRON MICROSCOPY

This trace residue collection kit contains all the necessary items for the uniform recovery of primer residue from a suspect shooter's hand. Access to a (SEM) scanning electron microscope is the only prerequisite.



No. GRA200 consists of:

- 1-No. GRA202 Gunshot Residue Collection Vial, Right Palm
- 1-No. GRA203 Gunshot Residue Collection Vial, Left Palm
- 1-No. GRA204 Gunshot Residue Collection Vial, Right Back
- 1-No. GRA205 Gunshot Residue Collection Vial, Left Back
- 1-No. GRA201 Test Data Label
- 1-No. TI3081 Instruction Sheet
- 2-No. KCP118 Integrity Seals
- 1-No. SF00761 Latex, Powder-Free Glove Pair
- 1-No. KCP223 Box, Plastic, 7" x 3 1/2" x 1"

CATALOG NO. GRA200 PRICE: \$16.95

PRIMER RESIDUE COLLECTION KIT

for analysis by ...

(SEM) SCANNING ELECTRON MICROSCOPY AND (AAA) ATOMIC ABSORPTION ANALYSIS

Specifically designed for those departments with access to scanning electron microscopy and atomic absorption analysis. The GRA series gunshot residue analysis kits feature special alloy aluminum specimen mounts containing no barium, lead or antimony—the most common constituents in primers. Simply remove the cap with carbon-covered metal stub, apply to the questioned hand area and return the metal stub to its original location in the holder. Specific and sensitive collection for gunshot residue in an economical and uncomplicated kit. Also included in the No. GRA100 are all the necessary components to collect primer residue for atomic absorption analysis.



No. GRA100 consists of:

- 1-No. TI3080 Instruction Sheet
- 1-No. GRA101 Gunshot Residue Collection Vial, Right Palm
- 1-No. GRA102 Gunshot Residue Collection Vial, Left Palm
- 1-No. GRA103 Gunshot Residue Collection Vial, Right Back
- 1-No. GRA104 Gunshot Residue Collection Vial, Left Back
- 1-No. GRA106 Bag, Zip-Top, 2" x 3", with 12 Each Long-Cotton-Tipped Applicators, 2 1/2"
- 1-No. KCP124 Vial, Left Back, Contaminant Free
- 1-No. KCP125 Vial, Right Back, Contaminant Free
- 1-No. KCP126 Vial, Left Palm, Contaminant Free
- 1-No. KCP127 Vial, Right Palm, Contaminant Free
- 1-No. SF00761 Latex, Powder Free Glove Pair, Ambidextrous
- 1-No. KCP123 Polyethylene Dispenser, 5% Nitric Acid with Controlled Flow Applicator and Molded Protective Cap, 3 ml
- 1-No. KCP128 Vial, Cartridge Case, Contaminant Free
- 1-No. KCP129 Vial, Control, Contaminant Free
- 2-No. KCP118 Integrity Seals
- 1-No. GRA100C Carton, 6 1/2" x 3 1/4" x 1 1/4" with Attached Integrity Seals



Collecting residue for scanning electron microscopy

CATALOG NO. GRA100 PRICE: \$24.95/EACH

TRACE METAL DETECTION KIT

A difficult problem in law enforcement is that of identifying and linking weapons, particularly in undischarged firearms, tools and like objects to specific individuals. The essential need for such identification in cases involving homicide, suicide, assault, burglary, robber and civil disorders has resulted in the development of a specific technique which shows whether an individual has been in contact with a particular metal object. Research has determined that metal objects leave traces on skin and clothing surfaces in characteristic patterns. The trace metal detection kit was developed to render these trace patterns visible to the investigating officer.

The trace metal detection technique (TMDT) makes such metal trace patterns visible when skin or clothing is treated with a test solution and then illuminated by shortwave ultraviolet light. Examination allows an investigator to determine whether or not a suspect has been in contact with certain metal objects, the type of metal or metals in the object and also to determine what type of weapon or metal object was handled.



Before reagent application



After reagent application and exposure to shortwave UV light

No. TMDT100 consists of:

- 12- No. FPT2541 Ink Cleaner Towelettes
 - 4- No. KCP230 AA-Cell Batteries, Alkaline
 - 1- No. SPU1 Spray Power Unit, with Tube
 - 1- No. SWL100 Shortwave Ultraviolet Light Source, 6VDC, 4-Watt Bulb
 - 4- No. TMDT01 Trace Metal Reagents, 1 oz.
 - 1- No. TMDT1001 Carrying Case, Molded Copolymer with Machined Plastic Insert
- Dimensions: 12 3/8" x 7 1/4" x 5 7/8"
Weight 3 lbs.



CATALOG NO. TMDT100.....PRICE: \$124.95

EXPLOSIVES RESIDUE TEST KIT

For verifying the presence of nitrites in explosive debris, this kit provides rapid screening for explosive residue. Due to improvements in the testing technique, the process is extremely sensitive and is ideal for field or lab use. This test has been performed with debris the size of a grain of salt and, while not conclusive for the presence of explosives, it is an effective screening tool for pinpointing "hot" locations.

No. ERTT10 consists of:

- 20- No. 288DP Pipettes, Disposable, with Capillary and 3 ml Bulb
 - 10- No. 290P1 P1 Color Developing Reagent, Ampoules, 2 ml
 - 1- No. ACN2 Acid Neutralizer, 2 oz.
 - 3- No. EIL011 Evidence Identification Labels, "Crime Evidence"
 - 10- No. ER1 Extract Reagent 1, Ampoules, 1 ml
 - 1- No. KCP139 Tweezers, Plastic, 4 3/4"
 - 1- No. KCP140 Spatula, Stainless, Micro
 - 3- No. KCP173 Vial, Glass, 1/2 oz. with Closure
 - 10- No. KCP174 TLC Plates, Silica Gel 60A, 250 um Layer, 5 cm x 10 cm
 - 10- No. KCP175 Pipettes, 10 Microliter, with Capillary
 - 15- No. KCP217 Cotton Balls
 - 10- No. KCP171 Vials, Glass, with closure, 1/2 dram
 - 1- No. SF00771 Latex Powdered Glove Pair, Ambidextrous, .005" Thick, Large
 - 1- No. ERTT101 Carrying Case, Molded Copolymer, with Latch
- Dimensions: 16 1/4" x 7 1/4" x 8 5/8"
Weight: 4 lbs.



CATALOG NO. ERTT10PRICE: \$225.50

MASTER FIREARMS DETECTION KIT

This is a necessary kit for the investigation of any crime involving the use of firearms. With this kit, the specific detection of primer residues (antimony and barium) and the determination of contact with a weapon (trace metal) can be performed. All the components are pre-measured and packaged, contaminant-free, for excellent sensitivity and unlimited laboratory testing.



FIREARMS DISCHARGE TESTS INCLUDED ARE:

- atomic absorption analysis/scanning electron microscopy
for: **barium, antimony, copper and lead**
- trace metal detection
for: **all metals**

No. MFD200 consists of

- 4-No. AAA10 Atomic Absorption Analysis Kits
- 4-No. SF00761 Latex, Powder-Free Disposable Glove Pairs, Ambidextrous, .005" Thick, Large
- 4-No. KCP230 AA-Cell Batteries, Alkaline
- 1-No. SPU1 Spray Power Units, with Tube
- 1-No. SWL100 Shortwave Ultraviolet Light Source, 6 VDC, 4-Watt Bulb
- 3-No. TMDT01 Trace Metal Reagents, 1 oz.
- 1-No. GRA200 (SEM) Scanning Electron Microscopy
- 1-No. MFD2001 Carrying Case, Molded Copolymer with Molded Plastic Inserts
Dimensions: 16 1/2" x 8 3/4" x 7 1/2"
Weight: 6 lbs.

CATALOG NO. MFD200 PRICE: \$199.50

SERIAL NUMBER RESTORATION

SERIAL NUMBER RESTORATION GEL

This is the latest development in etching chemicals. RESTOR-A-Gel® was developed to enable investigators to perform restoration in the field on any type of surface or metal. The gel consistency of the reagent permits application with a spatula to either a vertical or horizontal surface. No damming or tear-down of engine is required; applies just like grease. Gel reagents have 50% more concentration for minimum etching time; also can be used with the No. 284A accelerator.



Leading Particulars

- Separate gels for aluminum, copper and steel
- Increased concentration
- Simplified application
- Less danger to skin and eyes
- Use on horizontal or vertical surfaces
- Apply to surfaces previously impossible to etch
- Relatively inexpensive compared to liquid etching solutions
- Wide mouth 2 oz. glass jar

CATALOG NO.	DESCRIPTION	PRICE
RAG100	FOR STEEL	\$19.95
RAG200	FOR ALUMINUM	\$19.95
RAG300	FOR COPPER	\$19.95

SERIAL NUMBER RESTORATION LIQUID REAGENTS DISCHAPS

These are serial number restoration reagents in DISCHAP™ (disposable chemical applicator) form—convenient packaging prevents messy spills, clean-up and cross-contamination of chemicals while ensuring safe handling of corrosives. To use restorer DISCHAPS™, the surface is prepared in the usual method and a clay dam is built around the area to be restored. Next simply crush the ampoules in the disposable tubette, snip off the tip of the applicator tube and empty into clay dam. The glass ampoules are sealed in heavy-duty, acid-resistant polyethylene tubettes. DISCHAPS™ are ready for immediate use and may be disposed of safely. They are available only in packages of six each.



CATALOG NO.	DESCRIPTION	PRICE
DCR1	FOR STEEL (6/PACK)	\$23.95
DCR2	FOR ALUMINUM (6/PACK)	\$23.95
DCR3	FOR COPPER (6/PACK)	\$23.95

RESTOR-A-GEL® NUMBER RESTORATION KIT

This is a complete kit containing the necessary reagents to restore serial numbers and other identifying characteristics that have been destroyed—leaving no visible tracks. Obliterated marks on ferrous and non-ferrous metals can be restored to visibility with RESTOR-A-Gel® compounds.



No. RAG100 consists of:

- 1- No. ACN2 Acid Neutralizer, 2 oz.
- 6- No. KCP163 Emory Papers, 2" x 3"
- 1- No. KCP168 File, Bastard
- 1- No. KCP207 Vial, Amber, with Snap-On Cap, 30 dram
- 6- No. KCP209 Stirrers, Wood
- 15- No. KCP217 Cotton Balls
- 1- No. RAG300 Restor-A-Gel for Copper, 2 oz.
- 1- No. RAG100 Restor-A-Gel for Steel, 2 oz.
- 1- No. RAG200 Restor-A-Gel for Aluminum, 2 oz.
- 1- No. RAG5003 Metal Surfacing Solution, 2 oz.
- 1- No. RAG5004 Aluminum Surfacing Solution, 2 oz.
- 1- No. SF00771 Latex Powered Glove Pair, Ambidextrous, .005" Thick, Large
- 1- No. RAG5001 Carrying Case, Molded Copolymer, with Molded Plastic Inserts

CATALOG NO. RAG500	PRICE: \$99.50
--------------------------	----------------

SERIAL NUMBER RESTORATION

FIELD AND LABORATORY RESTORATION ACCELERATOR

This is an electrolytic-acid etching accelerator for use in restoring obliterated serial numbers and other identifying marks that have been removed by filing or grinding. It operates from self-contained dry cell batteries for maximum portability and flexibility. It has been totally re-designed with more simplified controls and improved circuitry. It is ideal for field or lab use. Reduce etching time from hours to minutes with the compact, lightweight model.

Leading Particulars

- Battery-operated for convenience and portability
- Variable current (use MIN for copper, aluminum and other soft metals; use MAX for steel, iron and all very hard metals)
- Variable pulse rate (use MIN for copper, aluminum and other soft metals; use MAX for steel, iron and all very hard metals)
- LED bar graph readout
- Use with liquid or "gel" reagents

Specifications

- **Bottom Cover:** 0.062" thick aluminum alloy, black wrinkle

paint

- **Outer Housing:** 0062" Thick aluminum alloy, tan wrinkle paint
- **Power Source:** Four "D" alkaline batteries
- **Probe Cord:** 4' 6" Cord, two phone plugs, one alligator clip
- **Probe, Large:** 2" L x 1/2" W brass electrode, phone plug adapter
- **Probe, Small:** 1" L x 1/2" W brass electrode, phone plug adapter
- **Side Covers:** 0.062" Thick aluminum alloy, black wrinkle paint
- **Dimensions and Weight:** 6 1/4" x 4 1/2" x 3 1/2"; 1.5 lbs.

CATALOG NO. 284A PRICE: \$119.95



SERIAL NUMBER RESTORATION REAGENTS FOR PLASTICS

This process permits restoring serial numbers on plastic—allowing field and lab technicians to develop original manufacturer's stamped serial numbers on most commercially available plastics, including items such as tvs and stereo equipment. RESTO-PLAS™ is simple to use. Merely apply the special reagent to the surface, air dry, then apply direct heat with a hot air dryer. Ground off numbers pop up for easy recording and photographing. Each reagent test unit includes 4 ml of plastic etching reagent in a resealable glass vial and four cotton-tip applicator swabs.

RPR1006 FOR PLASTIC (6/PACK) \$26.95



MASTER NUMBER RESTORATION KIT

This is a complete kit for use in the field or lab and permits the use of liquid etching reagents in resealable glass ampoules or the RESTOR-A-Gel® reagents. It includes all the necessary support equipment and the No. 284A restoration accelerator. Identifying marks on iron, steel, aluminum, copper and their alloys may be restored with ease with this kit. Complete instructions with application recommendations are included.

No. MNR100 consists of:

- 1- No. 284A Field Model Restoration Accelerator
- 3- No. 288DP Pipettes, Disposable, with Capillary and 3 ml Bulb
- 1- No. ACN2 Acid Neutralizer, 2 oz.
- 6- No. KCP163 Emory Papers, 2" x 3"
- 1- No. KCP168 File, Bastard
- 1- No. KCP197 Jar, 8 oz. Polystyrene, 70/400
- 6- No. KCP209 Stirrers, Wood
- 15- No. KCP217 Cotton Balls

- 4- No. KCP235 D-Cell Batteries, Alkaline
 - 2- No. NIA RESTOR-A-Gels® for Aluminum, 1/8 oz.
 - 2- No. NIC RESTOR-A-Gels® for Copper, 1/8 oz.
 - 2- No. NIS RESTOR-A-Gels® for Steel, 1/8 oz.
 - 1- No. RAG100 RESTOR-A-Gel® for Steel, 2 oz.
 - 1- No. RAG200 RESTOR-A-Gel® for Aluminum, 2 oz.
 - 1- No. RAG300 RESTOR-A-Gel® for Copper, 2 oz.
 - 1- No. RAG5003 Metal Surfacing Solution, 2 oz.
 - 1- No. RAG5004 Aluminum Surfacing Solution, 2 oz.
 - 1- No. SF00771 Latex Powdered Glove Pair, Ambidextrous, .005" Thick, Large
 - 1- No. STM1003 Modeling Clay, 1/4 lbs.
 - 1- No. MNR1001 Carrying Case, Vinyl Leatherette-Covered, with Steel Hardware
- Dimensions: 16 1/2" x 10 1/2" x 6 1/4"
Weight: 11.1 lbs.

CATALOG NO. MNR100 PRICE: \$179.50

PHYSIOLOGICAL FLUID TESTING SEMINAL FLUID

The frequency of sexual crimes is increasing alarmingly and the field investigator is compelled to gather and preserve highly fragile, unstable physical evidence. Considerable time is often saved when the investigator conducts presumptive, non-destructive chemical tests in order to localize and identify possible seminal stains. The following products are designed to aid in evidence identification and collection.

SEMINAL FLUID ...

The acid phosphatase test is considered to be the most conclusive, non-spermatozoa test for the presence of semen. The content of this enzyme is from 20 to 400 times greater in human semen than in any other fluid. This fact makes it unlikely that another material would test positive and give false results.

The reagents for determining the presence of acid phosphatase in suspected stains are sealed in glass ampoules to ensure their integrity and long life. Preliminary examination before testing should be accomplished with longwave ultraviolet lights or an alternate light source such as **BLUEMAXX™**.

The reagents should not be applied directly to suspected stains, thus eliminating the possible contamination in subsequent laboratory tests of the recovered evidence. The "contact" method, i.e., wetted filter paper, is touched to the suspect area and the reagent is then applied to the contact paper only.



Applying reagent to non-destructive contact transfer.



SEMINAL FLUID DISCHAPS™ (FOR DETECTION OF ACID PHOSPHATASE)

Seminal Fluid Dischaps™ feature pre-measured reagents, each individually sealed in a glass ampoule. The ampoules are then sealed in **SIRCHIE®**'s unique polyethylene applicators. This form of packaging ensures against contamination of reagents, while providing test integrity.

CATALOG NO.	DESCRIPTION	PRICE
DCS100	SIX INDIVIDUAL DISCHAPS WITH CONTACT PAPER/PACK	\$24.95

MASTER SEMINAL FLUID TEST KIT (FOR DETECTION OF ACID PHOSPHATASE)

This is a complete master field and lab kit that enables the investigator to perform contact testing and verification of suspected seminal stains. Components of the various reagents are sealed in glass ampoules to eliminate contamination and assure unlimited storage life. Applicators are disposable. Because of the specificity of the test, only minute quantities are required for identification and stains up to four years in age have responded positively. The contact transfer technique is used to verify the presence of semen eliminating contamination probability.

No. SF298 consists of:

- 8- No. 288DP Pipettes, Disposable, with Capillary and 3 ml Bulb
- 2- No. 288FP Contact Filter Papers, 1" x 2", 25 each
- 2- No. DISW2 Bottles of Distilled Water, 2 oz.
- 10- No. EIL011 Evidence Identification Labels, "Crime Evidence"
- 3- No. KCP172 Vials, Glass, 3 Dram, with Cap
- 15- No. KCP217 Cotton Balls
- 8- No. SF298S1 S1 Reagent, in Glass Ampoule, 5 ml
- 8- No. SF298S2 S2 Reagent, in Glass Ampoule, 2 ml
- 8- No. SF298S3 S3 Reagent, in Glass Ampoule, 1 ml
- 1- No. SF2981 Carrying Case, Vinyl Leatherette-Covered, with Steel Hardware
Dimensions: 13 1/2" x 10 1/2" x 5"
Weight: 4.9 lbs.



CATALOG NO. SF298	PRICE: \$119.50
-------------------------	-----------------

**PRELIMINARY BLOOD TESTING
AT THE CRIME SCENE**

Field tests of dried stains at the crime scene are often essential in locating and making preliminary presumptive identification of blood. Through the utilization of various kits and materials manufactured by **SIRCHIE®**, this initial testing becomes a routine function for the investigator. Tests for identifying blood are performed using a non-destructive technique that will not interfere with subsequent testing performed by the crime laboratory. All stains suspected of being blood should be chemically checked in the field, especially when their nature is doubtful. The most widely accepted field tests for blood involve three different chemical processes; phenolphthalein, leuco-malachite green and luminol. Each has its own particular characteristics.



Visible Reaction

Test	Sensitivity to Blood
1. Phenolphthalein	1:100,000
2. Leuco-Malachite	1:300,000
3. Luminol (in darkness)	1:5,000,000

MASTER FIELD AND LAB BLOOD TEST KIT

This kit contains all the essential equipment for blood testing in any field investigation situation. It has the advantage that all the reagents



are furnished in pre-measured quantities in the solid state and sealed in glass ampoules. This method of packaging permits the mixing of reagents in the field without measuring to give optimum concentration and sensitivity. All the necessary support equipment is included. The kit and accessory equipment are also suitable for laboratory use. Through the use of this kit, the field investigator can presumptively identify the presence or absence of blood.

No. MBT288 consists of:

- 18- No. 288DP Pipettes, Disposable, with Capillary and 3 ml Bulb
 - 2- No. 288FP Contact Filter Papers, 1" x 2", 25 each
 - 6- No. 288L1 Luminol Ampoule Reagents
 - 6- No. 288L2 Luminol Ampoule Reagents
 - 6- No. 288LM1 Leuco-Malachite Ampoules 1
 - 6- No. 288LM2 Leuco-Malachite Ampoules 2
 - 6- No. 288PX1 PX1 Reagent Ampoules, Phenolphthalein
 - 6- No. 288PX2 PX2 Reagent Ampoules, Phenolphthalein
 - 2- No. DISW2 Bottles of Distilled Water, 2 oz.
 - 2- No. KCP122 Blood Collection Tubes, 7 ml., with EDTA
 - 1- No. KCP213 Jar, Flint Glass, with Cap, 1 13/64 oz.
 - 15- No. KCP217 Cotton Balls
 - 1- No. SPU1 Spray Power Unit with Tube
 - 1- No. MBT2881 Carrying Case, Vinyl Leatherette-Covered, with Steel Hardware
- Dimensions: 13 1/2" x 10 1/2" x 4 1/2"
Weight: 4.5 lbs.

CATALOG NO. MBT288 PRICE: \$149.00

LATENT BLOOD DETECTION KIT (FOR DETECTION OF BLOOD PRINTS)

This kit offers an extremely sensitive method for detection and development of bloody prints on surfaces like plastic, wood, coated papers, metal and glass. Latent blood prints developed through the utilization of these reagents are very clear and chemically stable. Application: In most violent crimes, a profusion of blood is usually a result. Blood prints can be found on the weapon, floor, furniture and victim. In many instances, blood prints are not visible due to background color or the weakness of the blood print itself. To render these latent blood prints visible, the kit incorporates reagents extremely sensitive to blood prints and materials to lift the blood from any surface once developed.



No. BT001 consists of:

- 1-No. 131LT4 Hinge Lifter, Transparent, 4" x 4", 12 each
 - 6-No. 288DP Pipettes, Disposable, with Capillary and 3 ml Bulb
 - 6-No. BPD1 Blood Print Powder, 1 g
 - 1-No. BPD2 Blood Print Reagent, 2 oz.
 - 6-No. BPD3 Blood Print Solutions, 1 oz.
 - 6-No. BPD4 Blood Print Activators
 - 1-No. BPD5 Blood Print Lifter Solution, 2 oz.
 - 1-No. BPD6 Blood Print Lifter Valve Cleaner No. 6, 2 oz.
 - 1-No. BPD7 Blood Print Solution Valve Cleaner No. 7, 1 oz.
 - 2-No. SPU1 Spray Power Units with Tubes
 - 1-No. BT0011 Carrying Case
- Dimensions: 12 1/4" x 7 1/4" x 5 7/8"
Weight: 4 lbs.

CATALOG NO. BT001 PRICE: \$99.50



Contact stain on filter paper



Crushing reagent ampoules



Preparation shake



Reagent applied to suspect stain

DISCHAPS™ BLOOD TEST REAGENTS (DISPOSABLE CHEMICAL APPLICATORS)

DISCHAPS™ packaging virtually eliminates the possibility of contamination of chemical reagents and dramatically increases shelf life. Reagents are sealed in easily crushed glass ampoules. These ampoules are then sealed in tough, flexible polyethylene dispenser tubes. To use, simply crush the ampoules and shake for about 30 seconds. Moisten a piece of contact filter paper with water, apply the contact paper to the stain and remove, then apply reagent to the contact paper (not the original blood stain).

PHENOLPHTHALEIN DISCHAP™ SET

Blood causes a pink stain in just a few seconds. This test is considered by many field technicians as being one of the most reliable presumptive tests for the presence of blood. The set consists of six individual tests with contact paper.

CATALOG NO. DCB100 SET OF 6 PRICE: \$24.95

LEUCO-MALACHITE DISCHAP™ SET

An intense blue/green color reaction in three seconds is presumptive evidence that blood is present. Leuco-malachite green has long been a favorite of field investigators because of its high sensitivity (1:300,000). The set consists of six individual tests with contact paper.

CATALOG NO. DCB200 SET OF 6 PRICE: \$24.95

LUMINOL DISCHAP™ SET

Luminol reagent requires a darkened area for observation. This is the ideal reagent for "aged" or invisible blood stains. In fact, the older the stain, the brighter the reaction. Luminol is the most sensitive presumptive field test for blood (1:5,000,000). The set consists of six individual tests with contact paper.

CATALOG NO. DCB300 SET OF 6 PRICE: \$24.95



INVESTIGATOR'S FIELD BLOOD TEST KIT

This is a field blood test kit combining the three most efficient and effective reagents. The kit features luminol, leuco-malachite and phenolphthalein packaged in DISCHAPS™ (disposable chemical applicators). This complete kit includes four DISCHAPS™ of each reagent, distilled water and contact test paper. Instructions and a color chart are mounted permanently in the kit.

No. DCB400 consists of:

- 12- No. 288FP1 Contact Filter Papers, 1" x 2"
- 4- No. DCB1001 Phenolphthalein DISCHAPS™
- 4- No. DCB2001 Leuco-Malachite DISCHAPS™
- 4- No. DCB3001 Luminol DISCHASP™
- 1- No. DCB400C Chart, Sensitivity of Blood Test and Positive Reactions
- 1- No. DISW1 Distilled Water, 1 oz. with Dropper
- 1- No. KCP138 Scalpel, Disposable, 5"
- 1- No. DCB4001 Carrying Case, Textured, High-Density Polyethylene
Dimensions: 8 1/2" x 7 1/4" x 3 5/16"

CATALOG NO. DCB400 PRICE: \$69.50



LUMINOL INVISIBLE BLOOD REAGENT WITH SPRAY HEAD

A very useful test for searching large areas for blood especially if the area has been cleaned up. Invisible blood stains react with the Luminol reagent by luminescing—darkness is essential. Sensitivity: 1:5,000,000.

CATALOG NO. LUMINOL 16 16 OZ. WITH SPRAY HEAD PRICE: \$57.95



Narcotics Analysis Reagent Kit[®]

FOR PRESUMPTIVE FIELD TESTING OF DRUGS AND NARCOTICS

The NARK[®] (Narcotics Analysis Reagent Kit) is a field test kit that offers screening of the most frequently abused drugs and narcotics. Each kit contains enough chemicals for 80 individual tests. Reagents are packaged in disposable tubettes—a unique, easy-to-handle system. Each individual reagent is sealed in a thin, glass ampoule ensuring freshness and eliminating cross contamination with other reagents. The glass ampoules are secured in each end of the plastic tubette.

Narcotics Analysis Reagent Kit

NARK[®] is a compact, convenient field test kit offering presumptive identification of the most frequently abused drugs and narcotics:

- MARIJUANA
- HASHISH
- THC
- COCAINE
- CRACK/FREEBASE
- AMPHETAMINES
- BARBITURATES
- NARCOTIC ALKALOIDS
- OPIUM ALKALOIDS
- HALLUCINOGENS
- HEROIN
- MORPHINE



This is a positive color reaction for marijuana.

To conduct a test, simply remove the cap from the appropriate tubette and add a small quantity of the suspected substance. Recap the tubette and crush the ampoule(s) with a slight pressure between thumb and forefinger. Shake gently, then match the reaction with the color chart supplied in the kit.



DRUGS WILL SHOW THEIR COLORS ... *with* NARK®

Testing suspect drugs for their authenticity is simplified with the No. NAR100 kit. The kit contains enough reagents to conduct 80 individual tests on a variety of drugs.

No. NAR100 consists of:

- 1-No. NAR10001 Mayers Reagent for Narcotics Alkaloids, 10 each
- 1-No. NAR10002 Marquis Reagent for Opium and Alkaloids, 10 each
- 1-No. NAR10003 Nitric Acid Reagent for Heroin, Morphine, 10 each
- 1-No. NAR10004 Cobalt-Thiocyanate Reagent for Cocaine, Crack 10 each
- 1-No. NAR10005 Dille-Koppanyi Reagent for Barbiturates, 10 each
- 1-No. NAR10006 Mandelin Reagent for Amphetamines, 10 each
- 1-No. NAR10007 Erlich's Reagent for Hallucinogens, 10 each
- 1-No. NAR10008 Duquenois Reagent for Marijuana, Hashish, THC, 10 each
- 1-No. NAR10010 Poly Bags, 10 each
- 1-No. NAR10011 Acid Neutralizer, 1 oz. bottle
- 1-No. NAR10012 Polyethylene Case, 8 1/2" x 7" x 3 1/8"

Select a custom assortment from the tests listed below, if deviation from the tests listed in the NAR100 kit is desired—at no additional cost.



CATALOG NO. NAR100 PRICE: \$89.95

REPLACEMENT TESTS AND COMPONENTS

CATALOG NO.	DESCRIPTION	PRESUMPTIVE TEST FOR	PRICE
NAR10001	NO. 1 MAYERS REAGENT	NARCOTIC ALKALOIDS	\$9.96/BOX OF 10
NAR10002	NO. 2 MARQUIS REAGENT	OPIUM ALKALOIDS	\$9.96/BOX OF 10
NAR10003	NO. 3 NITRIC ACID REAGENT	HEROIN, MORPHINE	\$9.96/BOX OF 10
NAR10004	NO. 4 COBALT-THIOCYANATE REAGENT	COCAINE, CRACK	\$9.96/BOX OF 10
NAR10005	NO. 5 DILLE-KOPPANYI REAGENT	BARBITURATES	\$9.96/BOX OF 10
NAR10006	NO. 6 MANDELIN REAGENT	AMPHETAMINES	\$9.96/BOX OF 10
NAR10007	NO. 7 EHRLICH'S REAGENT	HALLUCINOGENS	\$9.96/BOX OF 10
NAR1008	NO. 8 DUQUENOIS REAGENT	MARIJUANA, HASHISH, THC	\$9.96/BOX OF 10
NAR1009	NO. 9 NDB (FAST BLUE B SALT) REAGENT	MARIJUANA, HASHISH, THC	\$9.96/BOX OF 10
NAR10013	NO. 13 MODIFIED COBALT-THIOCYANATE	COCAINE FREEBASE, CRACK	\$9.96/BOX OF 10
NAR10010	POLY BAGS		\$.50/BOX OF 10
NAR10011	ACID NEUTRALIZER		\$1.40/BOTTLE
NAR10012	POLYETHYLENE CASE		\$10.60/EACH
NAR10020	NARK CHART		\$2.00/EACH

THIN LAYER CHROMATOGRAPHY OF MARIJUANA

This is a rapid, specific test for marijuana utilizing a laboratory technique—simplified so that any officer may perform the test. No false positives will be encountered. The method is specific and has a sensitivity of 120 times that of the Duquenois test. Special consideration may be given the samples previously thought of as being insufficient for analysis. A complete kit for performing this layer chromatography that permits six complete, individual tests is available.

CATALOG NO. MZ020 KIT W/6 TEST PACKETS PRICE: \$68.50

CATALOG NO. MZ020A REPLACEMENT TEST PRICE: \$6.95



NARCOTICS ANALYSIS TESTING

NARK II™ NARCOTICS ANALYSIS KIT

SIRCHIE® Finger Print Laboratories, Inc. introduces the NARK II™ Progressive System for Drug Identification. NARK II™ has the capability of presumptively identifying several families of substances suspected of being abused drugs. Designed to function as a transportable narcotics laboratory, it is available for use wherever the need for its capability might arise. Each of the tests is comprised of one or more chemical reagents. When a predictable color or series of colors occur within a specific testing sequence, a positive confirmation may be presumed. Presumptive identification is generally recognized within our legal system as a component of probable cause. There is no drug identification system presently in use which completely eliminates the occurrence of false positives and false negatives. A forensic laboratory is required to qualitatively identify an unknown substance.

NARK II™ provides for presumptive identification of the following groups of drugs:

- Cannabis sativa L.
- Depressants
- Hallucinogens
 - Narcotics
- Stimulants



THREE PROGRESSIVE STEPS



Step 1. After removing the clip, insert a small amount of suspect drug into the test pouch.



Step 2. Break the ampoules from left to right and briefly agitate.



Step 3. Analyze the resulting colors.

NARK II™ NARCOTICS ANALYSIS KIT



The NARK II™ Progressive System of Drug Identification allows testing of the following substances:

- Amphetamine (Speed)
- Barbiturates
- Benactyzine
- Cannabis (Marijuana)
- Cocaine
- Codeine
- DMT (Businessman's High)
- Ephedrine (Over-the-counter, used to manufacture methamphetamine)
- Heroin (Smack, Tar)
- LSD (Acid)
- MDA (Mad Dog)
- MDMA (Ecstasy)
- Mescaline (Chocolate Mesc)
- Methadone
- Methamphetamine (Crank, Speed, Ice)
- Methcathinone
- Methedrine
- MMDA
- Morphine
- PCP (Killer Weed, Angel Dust, Dust)
- Psilocybin (Magic Mushrooms, Shrooms)
- Rohypnol (Roofies, Date Rape Drug)
- Talwin
- Valium

KITS

CAT. NO.	DESCRIPTION	PRICE
NARK200MK	MK—MASTER KIT—CONTAINS 130 TESTS AND NEUTRALIZER: Includes 2 boxes of Test 01 and 05, 1 box each of 02, 03, 04, 07, 08, 10, 11, 12, 15 and 06 Neutralizer.	\$192.00
NARK200IK	IK—INTERNATIONAL KIT—CONTAINS 130 TESTS AND NEUTRALIZER: Includes 1 box each of Test 01, 02, 03, 04, 05, 07, 08, 10, 11, 12, 13, 14, 15 and 06 Neutralizer.	\$198.00
NARK200CD	CD—CUSTOMS/DOUANES KIT—CONTAINS 50 TESTS AND NEUTRALIZER: Includes 1 box each of Test 01, 04, 07, 10, 15 and 06 Neutralizer.	\$88.00
NARK200MEG	MEG—MEG KIT—CONTAINS 50 TESTS AND NEUTRALIZER: Includes 1 box each of Test 01, 04, 07, LL, 11 and 06 Neutralizer.	\$90.00
NARK200PK	PK—PORT-A-KIT—CONTAINS 16 TESTS AND NEUTRALIZER: Includes 2 pouches each of Test 01, 02, 03, 04, 05, 07, 11, 15 and 06 Neutralizer.	\$39.00

REPLACEMENT TESTS AND COMPONENTS

CAT. NO.	DESCRIPTION	PRESUMPTIVE TEST FOR	PRICE
NARK2001	TEST 01—MARQUIS REAGENT/BOX OF 10	AMPHETAMINE TYPE COMPOUNDS HEROIN & OPIUM ALKALOIDS	\$10.40
NARK2002	TEST 02—NITRIC ACID/BOX OF 10	AMPHETAMINE TYPE COMPOUNDS HEROIN & OPIUM ALKALOIDS	\$10.40
NARK2003	TEST 03—DILLE-KOPPANYI/BOX OF 10	BARBITURATES	\$13.85
NARK2004	TEST 04—LYSERIC ACID DIETHYLAMIDE/BOX OF 10	LSD	\$16.80
NARK2005	TEST 05—DUQUENOIS-LEVINE/BOX OF 10	MARIHUANA, HASHISH, HASH-OIL & THC	\$17.70
NARK2006	06—ACID NEUTRALIZER/1 OZ. BOTTLE		\$1.75
NARK2007	TEST 07—SCOTT REAGENT (MODIFIED)/BOX OF 10	COCAINE SALTS & COCAINE BASE	\$17.70
NARK2008	TEST 08—METHADONE/BOX OF 10	METHADONE	\$15.00
NARK2009	TEST 09—PCP/BOX OF 10	PCP	\$15.00
NARK20010	TEST 10—SPECIAL OPIATES REAGENT (MECKE)/BOX OF 10	CODEINE, HEROIN, MORPHINE	\$15.40
NARK20011	TEST 11—MECKE'S (MODIFIED)/BOX OF 10	HEROIN, ECSTASY (MDMA)	\$15.90
NARK20012	TEST 12—TALWIN (PENTAZOCINE)/BOX OF 10	TALWIN	\$13.95
NARK20013	TEST 13—EPHEDRINE/BOX OF 10	EPHEDRINE	\$16.75
NARK20014	TEST 14—VALIUM, ROHYPNOL, METHCATHINONE/BOX OF 10	VALIUM, ROHYPNOL, METHCATHINONE	\$16.75
NARK20015	TEST 15—METHAMPHETAMINE/BOX OF 10	METHAMPHETAMINE	\$17.70

ACCESSORIES

CAT. NO.	DESCRIPTION	PRICE
NARK20016	PROGRESSIVE IDENTIFICATION CARD	\$2.75
NARK20017	PROGRESSIVE IDENTIFICATION WALL CHART	\$6.75
NARK20018	DRUG FIELD TEST RESULTS LOG (25-SHEET PAD)	\$0.60

DOCUMENT EXAMINATION PLATES

An advanced photographic technique permits the manufacture of these all-new, precision document examination plates. Fine line and accurate detail permit a more comprehensive analysis of a variety of situations, and viewing is simplified and shadows eliminated since the printed image is on the bottom of each glass plate. They are ideal for direct photography.

TYPE ANGLE PLATE

This plate is used to determine the angle of tilted characters, up to 5° in either direction. Place over typewritten page. Fine lines and accurate detail permit a more comprehensive analysis of a variety of situations. The printed image is on the bottom of the glass plate which eliminates shadows and allows for direct photography.

Dimensions: 7" x 5" x 1/16"

Weight: 3.1 oz

CATALOG NO. 370H PRICE: \$39.50



SLOPE PROTRACTOR AND LETTER FREQUENCY PLATE

The upper portion of this plate is used to determine the slant angle of handwriting in either direction. The lower section is used to determine letter frequency or the space factor of handwriting. Place over the hand written page. Fine lines and accurate detail permit a more comprehensive analysis of a variety of situations. The printed image is on the bottom of the glass plate, which eliminates shadows and allows for direct photography. Dimensions: 7" x 5" x 1/16". Weight: 3.1 oz.

CATALOG NO. 372H PRICE: \$39.50



TYPEWRITER MEASUREMENT PLATE

This plate is used to detect any abnormal horizontal or vertical alignment of typewritten characters. Place over the typewritten page. Fine lines and accurate detail permit a more comprehensive analysis of a variety of situations. The printed image is on the bottom of the glass plate, which eliminates shadows and allows for direct photography. Dimensions are: 10" x 8" x 1/16". Weight: 7.8 oz.

CATALOG NO. 371H PRICE: \$49.50

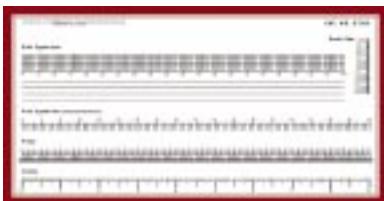

HANDWRITING LETTER SLANT AND COMPARISON PLATE

The upper portion of this plate is used to determine the slant angle of handwriting, up to 60° clockwise and 35° counterclockwise. The larger lower section is used to rapidly compare slant angle between questioned and known samples of handwriting. Simply place over the handwritten page. Degrees are spaced 1/4" apart for clarity. Fine lines and accurate detail permit a more comprehensive analysis of a variety of situations. The printed image is on the bottom of the glass plate, which eliminates shadows and allows for direct photography. Dimensions: 10" x 8" x 1/16". Weight: 7.8 oz.

CATALOG NO. 373H PRICE: \$49.50

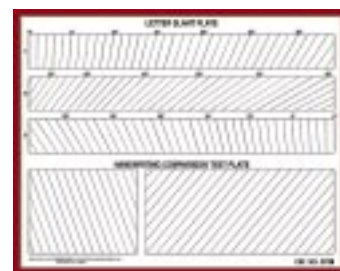

INDENTED WRITING RESTORATION KIT

Whenever writing is made on a leaf or sheet of a pad or book, not only is the top sheet affected, but the under sheets also receive impressions from which it is possible to determine the text of the original writing. These impressions are called "indented writing" and it is possible to develop these latent impressions with the reagents furnished with this kit. Individual application vials for the reagents provide unlimited storage life. Dimensions of the kit are: 8 3/8" x 4 1/2" x 1 3/4". Weight: 0.8 lbs.

No. IRS1001 consists of:

- 12- No. 288FP1 Contact Filter Papers, 1" x 2" each
- 1- No. IRS100 Indentation Removal Solution, 1 oz.
- 6- No. ISS3 Indentation Solutions, Strong

- 6- No. ISW1 Indentation Solution, Weak
- 6- No. KCP210 Swabs, Q-Tip
- 1- No. IRS10011 Carrying Case, Molded Polypropylene with Molded Plastic Inserts
- 12- No. KCP193 Brush, Applicator 3 1/4"

CATALOG NO. IRS1001 PRICE: \$49.50



HANDWRITING ANALYSIS INSTRUMENT



An excellent 5X magnifier and any one of 16 transparent analysis reticles may be assembled to make a very convenient handwriting analysis instrument. The combination of this unit with the reticles makes it a must for any investigator involved in handwriting analysis. Reticles: Use reticles for analyzing and comparing handwriting, typewriting and doodling. They may be used for critical measurement of slope angles, type height, type and writing thickness, radii and spacing. Both white and black line.

No. HC100 Leading Particulars

- Extreme accuracy
- Position any size document
- Low parallax
- Pull or twist focusing
- No special light source required
- Small, light and rugged
- Pocket model

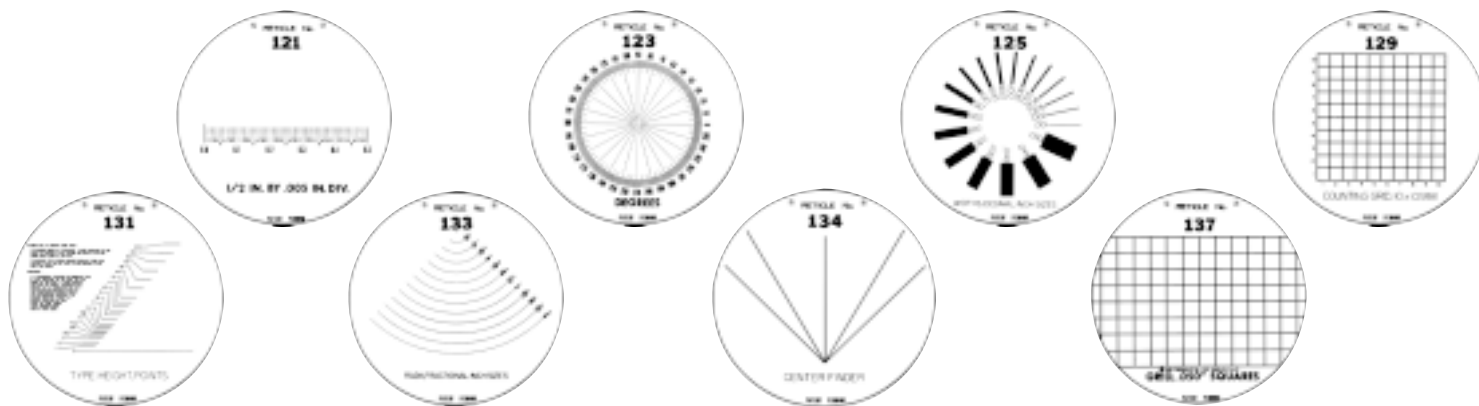

CATALOG NO. HC100 ... COMPLETE W/16 RETICLES .. PRICE: \$159.95

ERASED WRITING DETECTION KIT

This is the most complete erased writing detection kit available. It enables the investigator to restore erased writing with chemical or fuming reagents. An ultraviolet light is included for preliminary inspection of the questioned document prior to chemical treatment. A 5X magnifier is a necessary addition to the kit. The ultraviolet light may be converted to white light for microscope illumination. Individual applicator vials are provided for increased storage life and cross-contamination control.



No. EWD1001 consists of:

- 1- No. 214C1 Iodine Print Fixative, 1 oz.
- 1- No. 215CS1 Iodine Print Fixative Remover, 1 oz.
- 1- No. AMP2066 Iodette Ampoule, 3 g, 6 each
- 1- No. CUV100T UV Mini-Light, DC only
- 8- No. EINK1 Erased Ink #1, 2 ml vial
- 8- No. EINK2 Erased Ink #2, 2 ml vial
- 8- No. EINK3 Erased Ink #3, 2 ml vial
- 15- No. KCP217 Cotton Balls
- 1- No. KCP218 Lamp, Fluorescent, Cool White, 4 Watt
- 4- No. KCP230 AA-Cell Batteries, Alkaline
- 1- No. PFP200 Fingerprint Magnifier, Model M2
- 6- No. ZTE021 Zip-Top Evidence Bags, 9" x 12" x 4 mil
- 1- No. EWD10011 Carrying Case, Molded Copolymer, with Latch Dimensions; 14 1/2" x 8" x 7" Weight: 3.8 lbs.
- 24- No. KCP193 Brush, Applicator 3 1/4"

CATALOG NO. EWD1001 PRICE: \$139.95

PORTABLE INFRARED VIEWER

THE MICRON SERIES 940

Advanced technology now permits a fully portable infrared device for the questioned document examiner. **SIRCHIE®** engineers have developed a high resolution, lightweight (2.7 lbs) multipurpose, state-of-the-art unit, perfect for field or laboratory use.

Applications:

- Examination of obliterated/censored documents
- Viewing of aged, worn or charred documents
- Characterization and examination of inks and pigments
- Examination of works of art
- Studies of plant pathologies
- Examination of fossils and sediments

Leading Particulars:

- Dimensions: 5" x 3.5" x 13"
- Battery operated
- Self-contained
- Lightweight (2.7 lbs.)
- Fully field portable
- State-of-the-art power supply, illumination system and image converter

Specifications:

- Barrier filter: Infrared pass
- Power source: 2 ea. AA-cell alkaline batteries
- Infrared converter tube: electrostatic focus
- Spectral response: similar to JEDEC S-1
- External illumination system: 6 ultra-bright infrared LED's
- Peak wavelength: 940 nm.
- Battery life: 12 hours @ 70 degrees F estimated service life (battery life is increased when batteries are not under continuous use)



An examiner views an altered check with the No. MIC940.

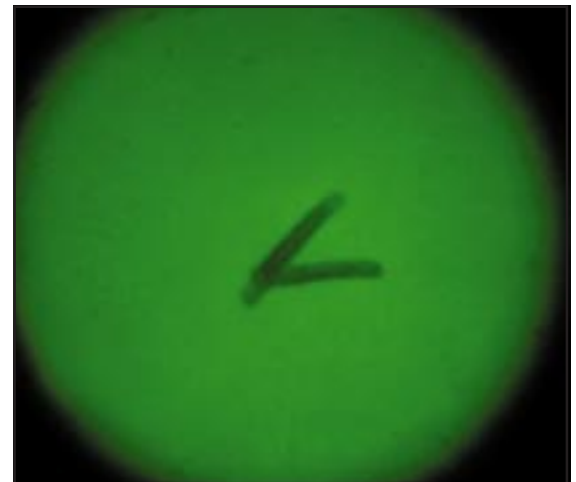

The numeral "1" has been altered to a "4" by addition of < .

The MIC940 consists of:

- 1 - Power module (consisting of battery holder, indicator lamp and switch for illumination system)
- 1 - Viewer module and stand (consisting of eyepiece, objective lens, barrier filter, infrared image converter tube and stand)
- 2 - AA alkaline batteries
- 1 - D alkaline battery
- 1 - Transit/Storage case with precut foam inserts.

CATALOG NO. MIC940 COMPLETE WITH TRANSIT/STORAGE CASE PRICE: \$1,695.00



APPLICATIONS

- **THIN LAYER CHROMATOGRAPHY ANALYSIS OF INKS**
- **ERASED WRITING DETECTION**
- **INDENTED WRITING RESTORATION**
- **INK COMPARISON**
- **ULTRAVIOLET EXAMINATION**
- **HANDWRITING AND TYPEWRITING ANALYSIS INSTRUMENTS**

MASTER QUESTIONED DOCUMENT KIT

This is one of the most complete kits available for the examination and analysis of questioned documents. The kit includes equipment for color analysis of inks, restoration of altered writing, indented writing, indented writing restoration and thin layer chromatography identification of ballpoint and felt tip pen ink. Also included is a combination longwave and shortwave ultraviolet light, 5X magnifier, optical analysis instrument and questioned document analysis plates. Complete instructions and procedures are included.

No. MQDA500 consists of:

- 1- No. 214C2 Iodine Print Fixative, 2 oz.
- 1- No. 215CS2 Iodine Print Fixative Remover, 2 oz.
- 10- No. 288DP Pipettes, Disposable, with Capillary and 3 ml Bulb
- 1- No. 316M Magnifier, 2.5X, 2 1/2" dia.
- 1- No. 374H Questioned Document Plate Combination, Set of 4
- 1- No. 782UV Tiger Twin Dual Longwave/Shortwave Ultraviolet Light Source, 6 VDC
- 1- No. ACN2 Acid Neutralizer, 2 oz.
- 1- No. AMP2066 Iodette Ampoule, 3 g, 6 each
- 1- No. DISW2 Bottles of Distilled Water, 2 oz.
- 4- No. EINK1 Erased Ink #1, 2 ml vial
- 4- No. EINK2 Erased Ink #2, 2 ml vial
- 4- No. EINK3 Erased Ink #3, 2 ml vial
- 4- No. ERBP01 Extract Reagents, Ballpoint Ink
- 1- No. ERDS4D Extract Reagent for Document Sampling
- 4- No. ERFT1 Extract Reagents, Felt Tip Ink
- 4- No. IR1 Ink Reagents No. 1
- 4- No. IR2 Ink Reagents No. 2
- 4- No. IR3 Ink Reagents No. 3
- 4- No. IR4 Ink Reagents No. 4
- 4- No. IR5 Ink Reagents No. 5
- 4- No. IR6 Ink Reagents No. 6
- 4- No. IR7 Ink Reagents No. 7
- 4- No. IR8 Ink Reagents No. 8
- 4- No. IR9 Ink Reagents No. 9
- 4- No. IR10 Ink Reagents No. 10
- 2- No. IRS100 Indentation Removal Solutions, 1 oz.
- 4- No. ISS3 Indentation Solutions, Strong
- 4- No. ISW1 Indentation Solutions, Weak
- 1- No. KCP139 Tweezers, Plastic, 4 3/4"
- 7- No. KCP154 Pipettes, with Suction Bulb
- 1- No. KCP166 Comparator, with Reticles
- 20- No. KCP167 Alligator Clips
- 10- No. KCP210 Swabs, Q-Tip
- 10- No. KCP215 Thin Layer Chromatography Sheets, 1" x 3"
- 24- No. KCP217 Cotton Balls
- 15- No. KCP227 Filter Papers, 1" x 2"
- 4- No. KCP228 Jars, Glass, with Closure, 4 oz.
- 4- No. KCP233 C-Cell Batteries, Alkaline
- 1- No. PFP200 Fingerprint Magnifier, Model M2
- 1- No. SF00771 Latex Powdered Glove Pair, Ambidextrous, .005" Thick, Large
- 4- No. TLC001A Mobile Solvent A
- 4- No. TLC001B Mobile Solvent B
- 4- No. TLC001C Mobile Solvent C
- 10- No. ZTE021 Iodette Fuming Bags, 9" x 12"
- 68- No. KCP193 Brush, Applicator 3 1/4"
- 1- No. MQDA5001 Leatherette Carrying Case, Dual Door
Dimensions: 24 1/4" x 20 3/8" x 8 5/8"
Weight: 36.1 lbs.

CATALOG NO. MQDA500 PRICE: \$625.00

PORTABLE POLICE LABORATORY



This is the most complete investigation unit in the world. Truly portable and versatile, this kit contains the largest selection of investigative aids available today. The reagents provided for testing blood, semen, narcotics and firearms residues are non-destructive contact methods and will not interfere with subsequent, formal laboratory analysis. The tests, when performed in the field will enable the investigator to search, screen and identify physical evidence. All the testing is performed through the utilization of pre-measured, disposable, non-contaminating ampoules, eliminating the possible contamination or misuse of the reagents.

No. 1000M consists of:

- 1- No. 101L1 Hi-Fi Volcano Latent Print Powder, Silk Black, 1 oz.
- 1- No. 103L1 Hi-Fi Volcano Latent Print Powder, Indestructible White, 1 oz.
- 2- No. 119L Spread Powder Brushes
- 2- No. 120L Max-Spread Powder Brushes
- 4- No. 122L1 Kit Size Fiberglass Brushes
- 1- No. 125L Permanent Magnetic Wand
- 1- No. 130LB Hinge Lifter, Black, 1 1/2" x 2", 24 each
- 1- No. 130LT Hinge Lifter, Transparent, 1 1/2" x 2", 24 each
- 1- No. 130LW Hinge Lifter, White, 1 1/2" x 2", 24 each
- 1- No. 131LT Hinge Lifter, Transparent, 2" x 4", 12 each
- 1- No. 131LT4 Hinge Lifter, Transparent, 4" x 4", 12 each
- 1- No. 144L Fingerprint Lifting Tape, Transparent, 1 1/2" x 360"
- 1- No. 145L Fingerprint Lifting Tape, Frosted, 1 1/2" x 360"
- 1- No. 146L Lifting Tape Dispenser, 1 1/2" Wide
- 1- No. 202C Ninhydrin Spray, 6 oz. aerosol
- 1- No. 203CS2 Ninhydrin Fixative, 2 oz.
- 1- No. 214C2 Iodine Print Fixative, 2 oz.
- 1- No. 215CS2 Iodine Print Fixative Remover, 2 oz.
- 1- No. 216CS Silver Nitrate Remover, 2 oz.
- 12- No. 288DP Pipettes, Disposable, with Capillary and 3 ml Bulb
- 4- No. 288L1 Luminol Ampoule Reagents
- 4- No. 288L2 Luminol Ampoule Reagents
- 4- No. 288LM1 Leuco-Malachite Ampoule 1
- 4- No. 288LM2 Leuco-Malachite Ampoule 2
- 4- No. 288PX1 PX1 Reagent Ampoules, Phenolphthalein
- 4- No. 288PX2 PX2 Reagent Ampoules, Phenolphthalein
- 1- No. 317M Magnifier, 2X, 3" dia.
- 1- No. 600E Photo Evidence Rule Tape, 1/2" x 30'
- 1- No. VS301 Visible Stain Powder, Green/Purple, 2 oz.
- 1- No. VS302 Visible Stain Powder, Mahogany/Blue, 2 oz.
- 1- No. 603E Evidence Identification Tape, 1" x 500"
- 1- No. UV5615 Three-Day Transparent Detection Fluid, Transparent/Black-Brown, 1/2 oz.
- 20- No. 621E1 Heat Seal Type Evidence Bags, 4" x 9"
- 10- No. 622E1 Heat Seal Type Evidence Bags, 8" x 12"
- 1- No. UV700 UV Ink Marking Pen
- 1- No. UV201 Fluorescent Invisible Detection Powder, Green/Green, 2 oz.
- 1- No. UV202 Fluorescent Invisible Detection Powder, White/Blue, 2 oz.
- 1- No. UV208 Fluorescent Invisible Detection Paste, Neutral/Green, 1 oz.
- 1- No. UV737 Invisible Fluorescent Crayon, White/Blue
- 1- No. UV738 Invisible Fluorescent Crayon, Yellow/Yellow

- 1- No. UV739 Invisible Fluorescent Crayon, Green/Green
- 1- No. 772SW Shortwave Ultraviolet Light Source, 6 VDC, 4-Watt
- 1- No. A211C Iodine Crystal Ampoules, 6 each
- 2- No. ACN2 Acid Neutralizer, 2 oz.
- 1- No. AMP2066 Iodette Ampoules, 3 g, 6 each
- 15- No. LPB1001 Lifted Print Backing/Sketch/Record Card, Black 3" X 5"
- 15- No. LPW1001 Lifted Print Backing/Sketch/Record Card, White 3" X 5"
- 4- No. DF201 Fumette Disposable Iodine Fuming Guns
- 2- No. DISW2 Bottles of Distilled Water, 2 oz.
- 25- No. EIL011 Evidence Identification Labels, "Crime Evidence"
- 25- No. FC3301 Criminal Record Cards, Standard, 8" x 8"
- 10- No. FC345L1 Postmortem Record Strips, Left Hand, Standard
- 10- No. FC345R1 Postmortem Record Strips, Right Hand, Standard
- 20- No. FTP2541 Ink Cleaner Towellets
- 1- No. FPT264 **SEARCH-I** Regular Fingerprint Cardholder
- 1- No. FPT267 Pocket Model Porelon® Fingerprint Pad
- 1- No. FPT2701 Wallet-Type Vinyl Pad Cover
- 1- No. FPT270A Elimination Pad, 50-Sheet
- 1- No. GL000 Carbide Tip Scriber
- 1- No. GL002 Retractable Lifter Knife with Blade
- 1- No. GL004 Retractable Ridge Counter
- 1- No. GRA200 Primer Residue Collection Kit
- 1- No. KCP110 Scissors, 5"
- 1- No. KCP139 Tweezers, Plastic, 4 3/4"
- 1- No. KCP144 China Marker, Black
- 1- No. KCP145 China Marker, White
- 2- No. KCP148 Syringes, 3 cc Disposable
- 8- No. KCP154 Pipettes, with Suction Bulb
- 5- No. KCP163 Emory Papers, 2" x 3"
- 6- No. KCP165 Stirring Rods, Glass, 5"
- 1- No. KCP168 File, Bastard
- 10- No. KCP209 Stirrers, Wood
- 10- No. KCP210 Swabs, Q-Tip
- 15- No. KCP217 Cotton Balls
- 25- No. KCP227 Filter Papers, 1" x 2"
- 1- No. KCP228A Jar, Glass, with Closure, 4 oz., Labeled "Mobile Phase ..."
- 1- No. KCP228B Jar, Glass, with Closure, 4 oz., Labeled "Color Developing ..."
- 3- No. KCP229 Masks, Surgical
- 4- No. KCP230 AA-Cell Batteries, Alkaline
- 1- No. KRL1012 Silver Nitrate Developer, 2 oz.
- 1- No. KRL103 Tissue Builder, 2 oz.

- 1- No. KRL1052 Finger Tissue Cleaner, 2 oz.
- 1- No. KRL1062 Tissue Builder Solvent, 2 oz.
- 1- No. KRL1102 Ninhydrin Remover, 2 oz.
- 1- No. LB003 Lifted Print Backing Sheet Pad, Gloss White
- 1- No. M115L Magnetic Latent Print Powder, Midnight Black
- 1- No. M116L Magnetic Latent Print Powder, White
- 1- No. M117L Magnetic Latent Print Powder, Gray
- 1- No. MZ010B Extract Reagent #1, 2 oz.
- 2- No. MZ020A Thin Layer Chromatography of Marijuana, Replacement Kits
- 1- No. NAR10002 Marquis Reagent for Opium and Alkaloids, 10 each
- 1- No. NAR10004 Cobalt-Thiocyanate Reagent for Cocaine, Crack, 10 each
- 1- No. NAR10005 Dille-Koppanyi Reagent for Barbiturates, 10 each
- 1- No. NAR10007 Erlich's Reagent for Hallucinogens, 10 each
- 1- No. NAR10008 Duquenois for Marijuana, Hashish, THC, 10 each
- 3- No. NIS Restor-A-Gel for Steel, 1/8 oz.
- 1- No. PFHB12 Classification Disc, Henry/Battley, for M1 and M2 Magnifier
- 1- No. PFP200 Fingerprint Magnifier, Model M2
- 1- No. PM283 Porelon® Postmortem Inking Tool
- 1- No. PMFS500 Postmortem Finger Straighteners
- 1- No. PMNS60 Postmortem Record Strip Holders
- 1- No. RAG100 Restor-A-Gel for Steel, 2 oz.
- 1- No. RAG200 Restor-A-Gel for Aluminum, 2 oz.
- 1- No. RAG300 Restor-A-Gel for Copper, 2 oz.
- 1- No. RAG5003 Metal Surfacing Solution, 2 oz.
- 1- No. RAG5004 Aluminum Surfacing Solution, 2 oz.
- 1- No. SF00771 Latex Powdered Glove Pair, Ambidextrous, .005" Thick, Large
- 4- No. SF298S1 S-1 Ampoule Reagents
- 4- No. SF298S2 S-2 Ampoule Reagents
- 4- No. SF298S3 S-3 Ampoule Reagents
- 1- No. SG202L1 Hi-Fi Latent Print Powder, Silver/Gray, 1 oz.
- 2- No. SPU1 Spray Power Units, with Tubes
- 1- No. SR301L1 Hi-Fi Latent Print Powder, Silver, Red, 1 oz.
- 2- No. TMDT01 Trace Metal Reagents, 1 oz.
- 6- No. ZTE021 Iodette Fuming Bags, 9" x 12"
- 1- No. 1000M1 Professional Portable Laboratory Kit, Leatherette, Vinyl-Covered, Multi-Section Doors and Pads and Drawers Dimensions: 28 5/8" x 22 1/8" x 10" Weight: 58 lbs.

CATALOG NO. 1000M PORTABLE POLICE LABORATORY PRICE: \$996.50

FORENSIC CONTAINMENT PRODUCTS

For the protection of evidence and personnel:

- cross contamination
- putrid odors
- harmful bacteria and viruses
- fingerprint developing chemicals and powders

SIRCHIE[®] Finger Print Laboratories, Inc. can provide your department with equipment for the preservation, drying and protection of important evidence from cross contamination. Our line of forensic evidence drying cabinets also protects your personnel from exposure to putrid odors due to decomposition and infectious pathogens.

SIRCHIE[®]'s ductless forensic work stations are helpful in the elimination of gases, vapors and particulate matter during processing evidence with powders, iodine, ninhydrin, DFO and cyanoacrylate. The workstations are excellent for drug identification where solvents and ethers are used in extractions to determine drug purity.

A major advantage is no expensive duct work is necessary for installation, which gives your department flexibility in its location.

Maintaining a clean work area is vital during PCR (polymerase chain reaction) preparation.

SIRCHIE[®] also has a PCR workstation. It is a state-of-the-art product for conducting these types of sensitive forensic operations.

SIRCHIE[®]'s forensic containment products meet and exceed OSHA and ANSI Z9.5 standards and guidelines.

SECTION XI-A TABLE OF CONTENTS

Forensic Containment Products

Evidence Drying Cabinet	274-275
Basic Forensic Workstation	276
Advanced Forensic Workstation	277
Identification Workstation	278
Forensic Drug Evidence Cabinet	279
PCR Workstation	280
Accessories	281

FORENSIC CONTAINMENT PRODUCTS

FORENSIC EVIDENCE DRYING CABINETS

Protect yourself and your evidence from infectious pathogens and noxious odors while reducing possible cross-contamination of evidence.

Dry and store evidence with **SIRCHIE**® Forensic Evidence Drying Cabinet. The cabinet protects your evidence from airborne particulate and cross-contamination while eliminating personnel exposure to putrid odors of decomposition and harmful bacteria or viruses. The unit is configured to clean the incoming "drying" air through pre-filtration and then filter the cabinet exhaust air through a combination of bonded carbon and HEPA filtration.

Decontamination of the **SIRCHIE**® evidence drying cabinet between cases eliminates residual DNA that may affect subsequent serology. **SIRCHIE**® offers a highly effective decontamination spray kit that will provide high-level disinfection of the cabinet. This spray also will help remove harmful pathogens from prefilters and HEPA filters. **SIRCHIE**®'s special bonded carbon filters are designed to remove the active (noncarcinogenic) ingredients in the **SIRCHIE**® spray-down solution.

Prior to decontamination the hose-down nozzle may be used to remove gross matter.

Interior shelves also may be removed for either high-temperature sterilization or low-temperature, high-level disinfection. The unit may be connected directly to a fixed drainage system, or the optional automatic pump may be added to the system for disposal convenience.

The drying cabinet can be outfitted with the AirSafe™ controller which adds many power features to the cabinet including:

- Timing of evidence drying cycle
- Monitoring of main HEPA filter life
- Automatic pump control and timing
- Automatic "lockout" feature ensures use of correct filters
- Cabinet use validation including cabinet hours
- Self diagnostic ensures safe operation
- Two-speed automatic blower setting with user pre-set low speed from 0-100% of blower max! Allows for user control of drying time.



Leading Particulars:

- All white structural polypropylene construction—the material of choice for hospital disinfection areas and pharmaceutical "clean" applications—**NO MORE RUST!**
- Exhaust air is HEPA-filtered to remove viral and bacterial pathogens plus other particulates to 99.997% efficiency at 0.3 microns
- Carbon filtration removes putrid odors and other gases. No after filter is required since the unit uses a unique bonded carbon filter—**NO FILTER DUST!**
- Automatic two-speed operation increases airflow to maximum when doors are opened
- Easily cleaned to prevent cross contamination between cases and evidence
- Custom shelves and drying racks available
- Locking front doors of 3/8" Lexan™
- Filter monitors indicate when to change door pre-filter and main HEPA filter. Safety alarms will warn of low airflow
- Units are available in standard 30-inch and 60-inch widths with 24" or 28" depths. No ducting required. Unit operates from a standard 110V electrical outlet
- Optional automatic waste pump to remove waste water up to 200 feet from cabinet

Shipping Weight:

- 30" Cabinet: 300 lbs.
- 60" Cabinet: 600 lbs.

Each evidence drying cabinet includes three shelves and standard plumbing

SIRCHIE®'s forensic containment products meet and exceed OSHA and ANSI Z9.5 standards and guidelines.

FORENSIC EVIDENCE DRYING CABINET FEATURES



The main cabinet filters are easily accessed with a special key to allow for removal and disposal of the bonded carbon and HEPA filters.



Optional automatic controller monitors all functions of the cabinet, from filter conditions to airflow.



The main cabinet prefilter can be changed easily between cases to prevent cross-contamination.



Shelves can be installed and removed with ease.



The automatic pump connection pumps waste water up to 200-feet from the cabinet.



• ACEVD60A pictured
• See page 281 for accessories



The water spray hose makes it easy to clean the unit.

CATALOG NO.	DESCRIPTION	PRICE
ACEVD30	DRYING CABINET, 30" X 24" X 84"	\$7,900.00
ACEVD30A	DRYING CABINET WITH AUTOMATIC CONTROLLER, 30" X 28" X 84"	\$9,250.00
ACEVD30D	DRYING CABINET, 30" X 28" X 84"	\$8,500.00
ACEVD60	DRYING CABINET, 60" X 24" X 84"	\$12,950.00
ACEVD60A	DRYING CABINET WITH AUTOMATIC CONTROLLER, 60" X 28" X 84"	\$14,750.00
ACEVD60D	DRYING CABINET, 60" X 28" X 84"	\$14,000.00
ACEVD10	REMOVABLE SHELF FOR DRYING CABINET	\$90.00

FORENSIC CONTAINMENT PRODUCTS

BASIC FORENSIC WORKSTATION

Protect operator and environment from toxic gases, vapors and particles.

The AC600 is an ideal unit for the containment of common chemicals and powders used in forensic analysis. The unit can be fitted with a carbon filter for gases or a HEPA filter for particulate. The unit has an integral base for containment of spillage. The AC600 is fitted with an automatic sensor on the lower sash. The controller allows for easy operation by all personnel. The unit meets and exceeds all applicable OSHA and ANSI standards for ductless fume hoods.

Physical Dimensions: Outside: 32"W x 20"H x 26"D Inside: 31"W x 20"H x 25"D

Shipping Weight: 120 lbs



Leading Particulars:

- All thermoplastic construction
- 360° visibility for ease of use
- Two- speed automatic operation for maximum containment
- Extremely quiet operation
- May be fitted with Model 300 AirSafe™ controller for automatic air flow detection and filter condition
- Optional sturdy cart bolts securely to the unit for portable operation
- Operates from a standard 110-volt electrical outlet
- Provided with an integral base constructed from polypropylene which may be removed for mounting over a sink
- Optional fuming box for use with cyanoacrylates
- No installation cost
- Unit available in 12V configuration—operates from a cigarette lighter in vehicle or optional battery pack. Excellent for field use

Typical Applications:

- Removal of dust and fumes from fingerprint powders, cyanoacrylates, iodine, ninhydrin and DFO.
- Drug identification where solvents and ethers are used in extractions to determine drug purity.
- Weighing of dangerous particulates.
- Elimination of putrid odor from decaying evidence.

SIRCHIE®'s forensic containment products meet and exceed OSHA and ANSI Z9.5 standards and guidelines.

CATALOG NO.	DESCRIPTION	PRICE
AC600	FORENSIC WORKSTATION W/2-SPEED AUTOMATIC CONTROLLER	\$1,650.00
AC600A.....	FORENSIC WORKSTATION WITH AIRSAFE™ CONTROLLER	\$2,300.00
AC600V.....	FORENSIC WORKSTATION W/2-SPEED AUTOMATIC CONTROLLER, 12V ...	\$1,950.00
ACALGFL	EXTERNAL FLUORESCENT LIGHT KIT FOR AC600	\$120.00
ACAHMON	HEPA FILTER MONITOR*	\$150.00
*(HEPA FILTER MONITOR NOT NECESSARY IF AIRSAFE™ CONTROLLER IS PURCHASED)		
ACFPRE	PARTICULATE FILTERS**/10-PACK	\$125.00
**(USED WITH FILTERS BELOW. EFFICIENCY 99.997% AT 0.3 MICRONS.)		
ACFHEPA	HEPA FILTER FOR CONTAINMENT OF PARTICULATE	\$175.00
ACF100	22-POUND, BONDED CARBON-ACTIVATED FILTER	\$295.00

ADVANCED FORENSIC WORKSTATION

Multi-purpose cabinet which protects operator and environment from typical forensic applications.

The advanced forensic workstation is designed for those laboratories that don't want to change filters between applications. With the dual filter bed, the AC6200 is the perfect choice for those departments who process a large volume of evidence with powder and chemicals. Simply stack a HEPA filter, with an electrostatically charged pre-filter attached, in the bottom of the unit and place a bonded chemically absorbent carbon filter on top to complete the basic forensic application configuration. The AC6200 also has a large vertical workspace to accommodate a microscope or a fuming stand. The unit is available in a manual dual-speed configuration as well as with the AirSafe™ Automatic Controller.

Physical Dimensions:

Outside: 32"W x 42"H x 26"D Inside: 31"W x 27"H x 25"D

Shipping Weight: 160 lbs.

Features:

- Large vertical workspace
- 360° visibility for ease of use
- Dual speed or automatic controller to maintain airflow
- Integral base constructed of polypropylene
- Extremely quiet operation
- Meets OSHA & ANZI Z9.5 standard and guidelines
- No installation cost



SIRCHIE®'s forensic containment products meet and exceed OSHA and ANSI Z9.5 standards and guidelines.

CATALOG NO.	DESCRIPTION	PRICE
AC6200	FORENSIC WORKSTATION WITH 2-SPEED AUTOMATIC CONTROLLER	\$1,995.00
AC6200A.....	FORENSIC WORKSTATION WITH AIRSAFE™ CONTROLLER	\$2,645.00
ACALGFL	EXTERNAL FLUORESCENT LIGHT KIT FOR AC6200	\$120.00
ACAHMON	HEPA FILTER MONITOR*	\$150.00
*HEPA FILTER MONITOR NOT NECESSARY IF AIRSAFE™ CONTROLLER IS PURCHASED		
ACFPRE	PARTICULATE FILTERS/10-PACK**	\$125.00
** (USED WITH FILTERS BELOW. EFFICIENCY 99.997% AT 0.3 MICRONS.)		
ACFHEPA	HEPA FILTER FOR CONTAINMENT OF PARTICULATE	\$175.00
ACF100	22-POUND, BONDED CARBON-ACTIVATED FILTER	\$295.00

IDENTIFICATION WORKSTATION

Custom-designed for high-volume identification work.

The Identification Workstation series of ductless fume hood enclosures are ideal for protection of the operator from toxic gases and particulates used in routine analysis. The unit protects the operator from residual cyanoacrylate and aluminum-based powders used in forensic analysis. Other commonly used chemicals, such as methanol, xylene and acetone, are also contained.

Identification Workstations are available in the two-speed controller model or with the AirSafe™ Controller. The two-speed model offers excellent protection to the operator. The lower sash is outfitted with an electromagnetic controller that senses when the sash is lifted. When the sash is raised, the blower increases velocity to compensate for the additional opening. The AirSafe™ Controller automatically monitors filter life and airflow conditions. The AirSafe™ controller, not your nose, detects when to change the filters.

Physical Dimensions:

AC3000 Outside: 36"W x 54"H x 29.5"D Inside: 35"W x 35"H x 29"D

AC4000 Outside: 48"W x 54"H x 29.5"D Inside: 47"W x 35"H x 29"D

Shipping Weight:

AC3000: 250 lbs

AC4000: 325 lbs.

Leading Particulars:

- All surfaces in contact with corrosive fumes and liquids are structural polypropylene—**NO MORE RUST!**
- Special "cocktail" carbon filter for common forensics chemicals
- HEPA filter removes powders at 99.997% efficiency at 0.3 microns
- Easily cleaned to prevent cross-contamination between cases or batches of documents
- AirSafe™ controller monitors and displays airflow face velocity on alphanumeric display
- Filter condition is monitored by AirSafe™ controller and user is warned when to change the carbon and HEPA filters
- 30-Watt integral fluorescent light
- Face velocities exceed OSHA standards
- No installation cost
- Optional sturdy cart may be purchased to make unit mobile
- Adequate workspace to allow for superglue tank to be placed inside
- All units operate from a standard 10 amp 110V electrical outlet
- Units are shipped ready to use.

SIRCHIE®'s forensic containment products meet and exceed OSHA and ANSI Z9.5 standards and guidelines.



Custom fume hood configurations available.

CATALOG NO.	DESCRIPTION	PRICE
AC3000	36" WORKSTATION (AIRSAFE™ AUTOMATIC CONTROLLER)*	\$5,900.00
AC3000B	36" WORKSTATION (AUTOMATIC TWO-SPEED)*	\$4,900.00
AC4000	48" WORKSTATION (AIRSAFE™ AUTOMATIC CONTROLLER)**	\$6,900.00
AC4000B	48" WORKSTATION (AUTOMATIC TWO-SPEED)**	\$5,900.00
* AC3000 MODELS REQUIRE TWO LIKE FILTERS.		
**AC4000 MODELS REQUIRE THREE LIKE FILTERS.		
ACFHEPA	HEPA FILTER FOR CONTAINMENT OF PARTICULATE	\$175.00
ACF100	22-POUND, BONDED CARBON-ACTIVATED FILTER	\$295.00

AC4000LFC2 FORENSIC DRUG EVIDENCE CABINET

The Forensic Drug Evidence Cabinet protects evidence and the operator while completing analysis.

The AC4000LFC2 is designed for both search and seizure operations at border crossings and also for drug analysis in a laboratory setting. The unit protects both the operator and the evidence from exposure and contamination. The unit provides a laminar flow class 2 environment for opening and analysis of evidence with complete protection of the operator from exposure to toxic particulate or gases. The unit is completely self-contained and designed to be mobile so that it can be moved to specific critical locations.

Shipping Weight: 375 lbs.



Leading Particulars:

- All polypropylene “seamless” construction for maintenance of a clean sterile environment
- Model 300 controller to constantly monitor face velocity and adjust blower speed to maintain a balanced flow of laminar air
- 30-Watt fluorescent light
- Removable perforated base for ease of cleaning
- An optional spill drain is available to remove liquids collected in the base
- Pre-filters located in base capture particulate to 0.3 microns at 95% efficiency
- Sash openings of 8 inches and 16 inches
- High efficiency HEPA filter filters particles to 0.3 microns at 99.997% efficiency
- Carbon filters, for gases, may be installed in either recirculating mode or to filter the total exhaust
- Cabinet is shipped ready for use
- No installation cost

AC4000LFC2 Specifications:

Width 50” OD, 48” ID
 Height 56” OD, 36” ID
 Depth 30” OD
 Construction Polypropylene
 Face Velocity 80 - 100 LFM
 AirSafe Control Standard
 Voltage 110V-120V
 Power 616W
 Lighting 30W Fluorescent
 Airflow 660 CFm Max

SIRCHIE®’s forensic containment products meet and exceed OSHA and ANSI Z9.5 standards and guidelines.

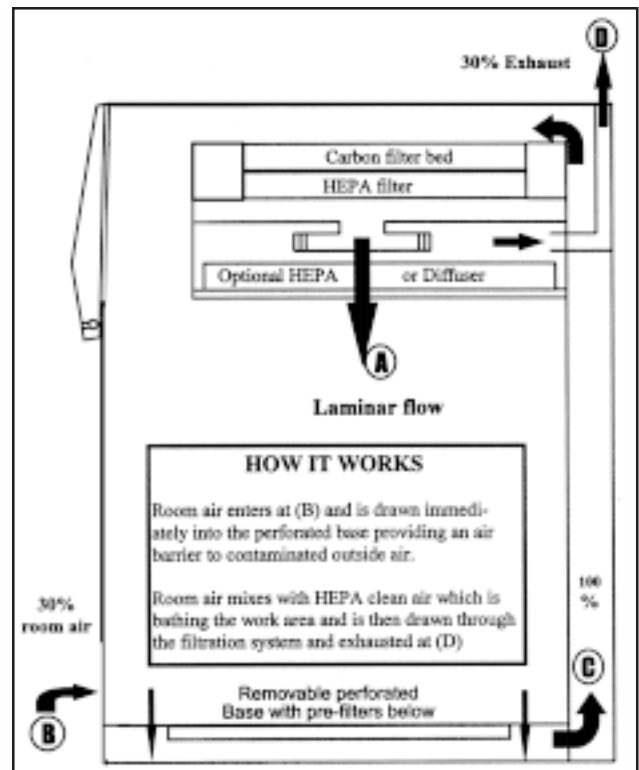

CATALOG NO.	DESCRIPTION	PRICE
AC4000LFC2	CLASS II LAMINAR FLOW HOOD	\$9,500.00

PCR WORKSTATION

Get Results—Not Background! Polymerase Chain Reaction.

The PCR Workstation allows you to maintain a clean work area during your PCR preparation. The unit has an optional built-in UV light to irradiate tubes, flasks and pipettes between amplifications. This UV light sterilization effectively destroys potentially contaminating DNA and RNA in minutes. The low-profile design will fit in your current work area. The bi-fold sash minimizes disturbances during critical transfers. For units fitted with UV light sterilization, a safety lock turns the UV light off when the sash is raised—ensuring operator protection at all times. Model AC600DB features a circulation-free environment with UV light sterilization. It has a UV light with a 0-10 minute timer for sterilization between amplifications. A safety interlock switch prevents exposure to UV light when the sash is raised. Model AC600LF provides class 100 vertical laminar flow air through a 99.997% HEPA filter. Model AC600FLUV combines a class 100 clean air environment with timed UV light sterilization for optimal protection from sample contamination. Raising the bi-fold sash turns off the UV light and activates the blower.

Physical Dimensions:

Outside: 32"W x 20"H x 26"D Inside: 31"W x 20"H x 25"D

Shipping Weight: 100 lbs.



Leading Particulars:

- Class 100 vertical laminar flow
- Optional UV timed light for sterilization
- Bi-fold sash with safety interlock
- Low-profile design using all thermoplastic construction
- Integral base for easy cleaning
- Optional two speed blower
- 360° visibility for ease of use
- Bench top or portable with addition of optional cart

Options:

- Two-speed blower increases filter life and enables ultra-quiet background operation
- Variable blower controller for 0-100% control
- HEPA filter monitor tells you when to change the filter
- Custom sturdy cart allows the unit to be made portable

CATALOG#	DESCRIPTION	PRICE
AC600DB	32" DEAD AIR BOX WITH TIMED UV LIGHT FOR STERILIZATION	\$1,495.00
AC600LF	32" CLASS 100 VERTICAL LAMINAR FLOW HOOD	\$1,995.00
AC600FLUV	32" COMBINATION UNIT*	\$2,450.00

*INCLUDES CLASS 100 VERTICAL LAMINAR AIR FLOW AND TIMED UV LIGHT FOR STERILIZATION.

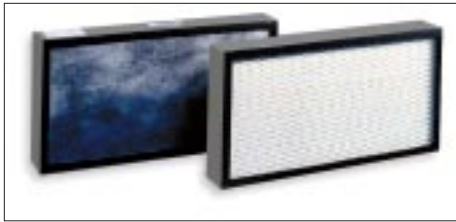

Bonded Carbon and HEPA Filters



Temprite Sterilization Unit



Automatic Waste Pump



Cyanoacrylate Fuming Enclosure



High-Level Disinfection Spray

ACTIVATED CARBON FILTER

A revolutionary, bonded carbon design makes this filter ideal for organic vapors, odors and fumes, including alcohols, acetone, xylene, methylene chloride and other forensic applications. The high grade of coconut shell (in its bonded state) allows for an exceptional degree of absorbcency. NO CARBON DUST!

CAT. NO. ACF100 PRICE: \$295.00

COMBINATION FILTER (NOT PICTURED)

This bonded carbon filter is used in the evidence drying cabinets for of absorbing the fumes and odors associated with the drying and decaying of bloody articles.

CAT. NO. ACF300 PRICE: \$390.00

HEPA FILTER

High efficiency particulate air (HEPA) filters have an efficiency rating of 99.997% for collection at 0.3 microns. This filter is used for containment of particles—toxic powders, asbestos, lead, fingerprinting powders, etc.

CAT. NO. ACFHEPA PRICE: \$175.00

PARTICULATE PRE-FILTER (NOT PICTURED)

The particulate pre-filter is an electrostatically charged fiber filter that removes submicron particulates. This filter is used to protect the absorption filters from contamination. Each absorption filter is fitted with a pre-filter at the time of purchase.

CAT. NO. ACFPRE PRICE: \$125.00/10-PK

TEMPRITE STERILIZATION UNIT

An optional sterilization unit is available for vaporizing glutaraldehyde or formaldehyde prior to changing the main system HEPA filters. The unit is microprocessor-controlled to hold sterilants at the exact temperature required for vaporization.

CAT. NO. ACEVD14 \$950.00

AUTOMATIC WASTE PUMP

The optional automatic waste pump is designed to remove waste water up to 200 feet from the evidence drying cabinet. An ideal option when the cabinet cannot be placed near a drain.

CAT. NO. ACEVD12 \$449.00

CYANOACRYLATE FUMING ENCLOSURE

This enclosure is designed to be used inside a ductless fume enclosure when processing evidence with cyanoacrylate. The enclosure is constructed of PETG blend which is a surface that cyanoacrylate does not adhere to as freely as other fuming enclosures. The enclosure has a handle on each end to allow for ease of use. Size: 20"W x 14"D x 12"H.

CAT. NO. ACFUME \$135.00

HIGH-LEVEL DISINFECTION SPRAY

The use of SIRCHIE®'s high level disinfection spray is recommended as proper method of cleaning the evidence drying cabinet in between cases. The disinfect is FDA approved. Sold in sixteen ounce spray bottle.

CAT. NO. ACEVD16 \$140.00/12 BOTTLES

CAT. NO. ACEVD22

GLUTARALDEHYDE W/ NEUTRALIZER , 1 GALLON \$62.50

SECTION XII TABLE OF CONTENTS

Weapons and Metal Detection Products

Letterbomb Detector283B

SEARCHALERT® 283

SEARCHBATON™, MI55283A

WEAPONS AND METAL DETECTION

Whether for security screening or area searches, **SIRCHIE**® offers metal detection systems to meet many specific needs.

A full line of complementary hand-held search devices with detection thresholds at or below 0.1 grams of metal is offered, including the MI55 SEARCHBATON™ with omni-directional search capability. Because **SIRCHIE**®'s units are self-adjusting, operators are more likely to remain focused on the nuances of behavior of their search subjects.

To screen items of mail and other such sealed materials, **SIRCHIE**®'s letter bomb detectors offer a decided advantage in time and efficiency over hand-held detectors. These detectors easily detect the minute amounts of metal used to wire letter bombs and respond with a visual or audible alarm.

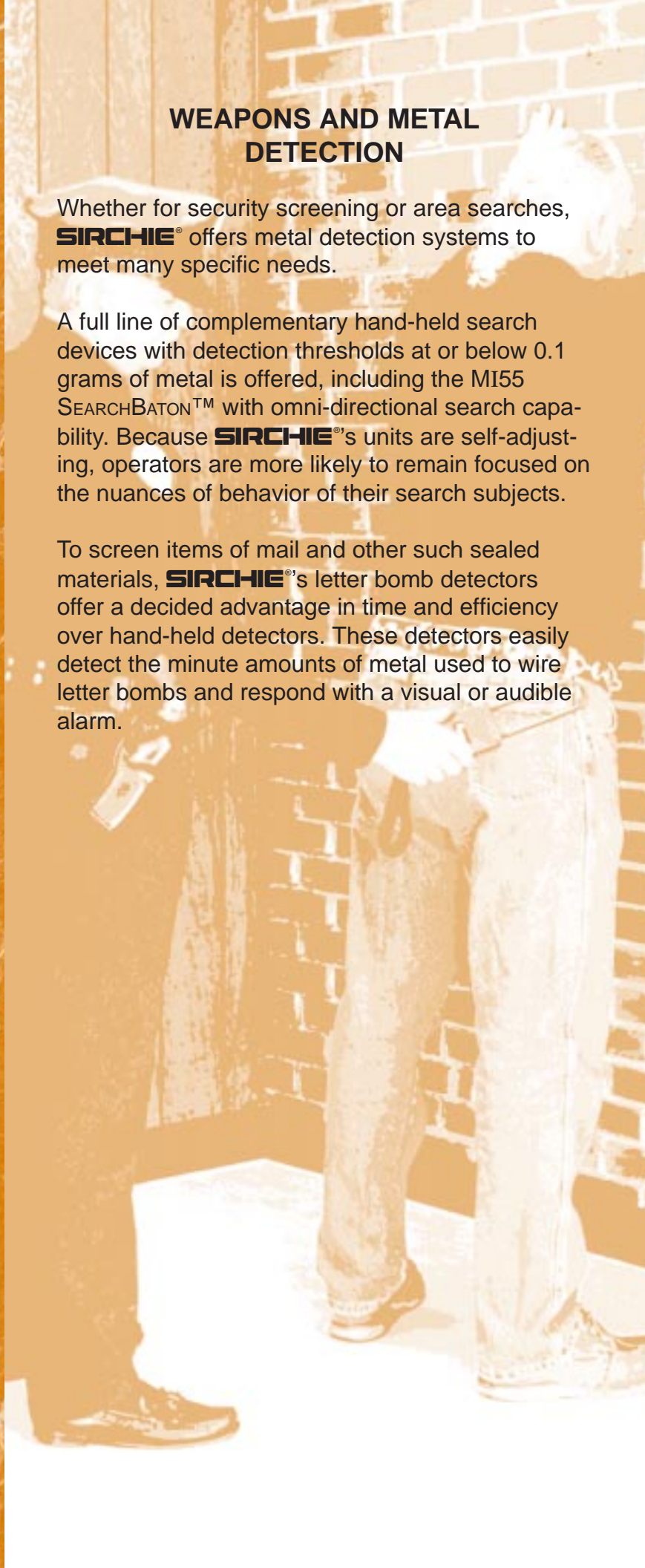

the **MI45 SEARCHALERT®**



The MI45 is pictured in use.

This unit is a compact, lightweight, durable and easy-to-operate hand-held metal detector for use in detecting metal objects on a person's body.

It is ideally suited for use in any security situation. One simple tuning control allows adjustment for various sizes of metal objects and situations, depending upon specific needs.

The SEARCHALERT® is capable of detecting a paper clip from two inches away, or, with a quick adjustment of the control, smaller objects such as loose change or keys can be easily bypassed, and metal objects of larger size only will be detected.

Physical contact is not necessary on body searches due to the pinpoint accuracy of the unique case-mounted Faraday-shielded search coil. The SEARCHALERT® detects all metals, both ferrous and nonferrous, and produces both a visual and audible alarm with its built-in 2 1/4" speaker and case-mounted LED.

For private alarm indication, the optional earphone attachment (MI45E) ensures that only the operator is aware of the alarm by disabling the speaker and LED and channeling all audio directly to the earphone. A rechargeable nickel-cadmium model (MI45RE) is available.

Leading Particulars

- **Construction:** Rugged ABS thermoplastic injection-molded case
- **Power Source:** One 9-volt alkaline battery (MI45 and MI45E); one 9-volt NiCad battery with 110 VAC charger (MI45RE)
- **Size:** 12 1/4" long x 2 3/4" wide x 2" deep
- **Weight:** 11 oz.
- **Operation:** Single-control tuning, on/off switch
- **Alarms:** Audible: (internal), 2 1/4" dia. speaker (all models); (external) earphone and jack (MI45E only); visual: case-mounted red LED
- **Circuitry:** All solid state, internally shielded, beat frequency oscillator
- **Detection Sensitivity:** Minimum of 0.1 g
- **Operating Frequency:** 70 kHz
- **Audio Frequency:** 0 Hz to 10 kHz
- **Standby Current:** 12 ma typical
- **Battery Life (typical):** 24-30 hours (MI45 and MI45E); 5-7 hours (MI45RE)
- **Carrying Case:** Lined vinyl holster with belt clip



The MI45RE is pictured with its battery charger.

CATALOG NO.	DESCRIPTION	PRICE
MI45	SEARCHALERT® WITH HOLSTER	\$129.95
MI45E	SEARCHALERT® WITH EARPHONE AND HOLSTER	\$139.50
MI45RE	SEARCHALERT® WITH NICAD BATTERY, 110 VAC CHARGER AND HOLSTER	\$164.95

WEAPONS AND METAL DETECTION



the body scanner for ...

- SCHOOLS
- COURTHOUSES
- TRANSPORTATION FACILITIES
- ANY SECURITY-DEMANDING ENVIRONMENT
- CORPORATE COMPLEXES
- SPORTING EVENTS
- PRISONS



MAXIMUM SECURITY AT YOUR FINGERTIPS

The MI55 is pictured in use.

MI55 SEARCHBATON™

The MI55 is the ultimate in personal metal detection offering unparalleled performance and dependability in an attractive, easy-to-use, billy-club configuration. Ideal for use in courthouses, prison systems, schools, or corporate complexes, the SEARCHBATON™'s 360-degree search capability allows for rapid and effective searches without having to be held at specific angles like conventional metal detectors require. The internal ferromagnetic transceiver module detects metal equally in a 360-degree field perpendicular to the unit and requires no tuning or operator adjustment as it is completely self-tuning. Momentary or sustained operation is available by use of the dual-action power switch. Metal detection is clearly indicated both visually and audibly by the internal audible alarm and the red LED indicator. It is extremely sensitive and commands respect by its very appearance. Housed in a machined, weatherproof ABS extruded plastic barrel with comfortable knurled hand grip and wrist strap, the SEARCHBATON™ provides service for the most demanding environments.

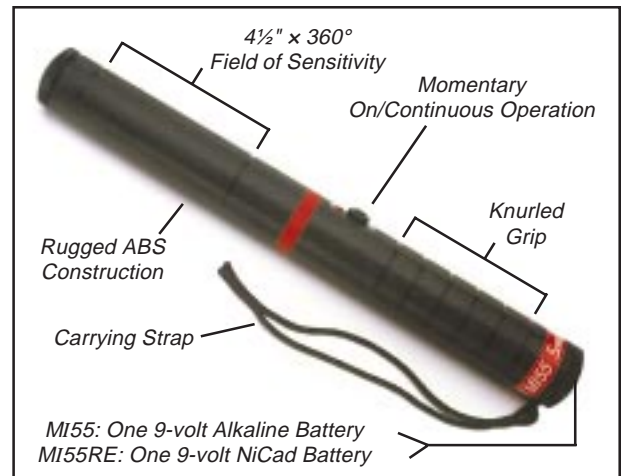

The SEARCHBATON™ features 360° sensitivity.

Leading Particulars

- **Ferromagnetic Transceiver Module:** Provides a full 360° search area
- **Construction:** High-impact, knurled ABS thermo-plastic
- **Power Source:** Single, standard 9-volt alkaline battery (No. MI55) or single, 9-volt nickel-cadmium (No. MI55RE)
- **Size:** 1 3/4" (44 mm) diameter x 15 1/2" (394 mm) long
- **Weight:** Approximately 1 lb. (1/2 kg)
- **Circuitry:** Integrated circuit technology; transmit/receive, self-balancing, internally shielded
- **Detection Sensitivity:** Minimum of 0.09 g
- **Alarm Indicators:** Audible—3.3 kHz, fixed, internal visual—external red LED
- **Standby Current:** 13 milliamps typical
- Momentary On or Continuous operation
- Comfortable hand grip and weight distribution
- **Battery Life:** 27 hours (MI55); 5 hours (MI55RE) rechargeable

CATALOG NO.	DESCRIPTION	PRICE
MI55	BATON W/STANDARD 9-VOLT BATTERY	\$169.95
MI55RE	BATON W/9-VOLT NICKEL-CADMIUM BATTERY WITH 110 VAC CHARGER	\$199.50

LETTERBOMB DETECTOR

The **SIRCHIE®** letterbomb detector is specifically designed to counter the increasing menace of terrorism for both corporate and government installations. Its unique design incorporates a freestanding structure comprised of a highly sensitive, self-tuning, balanced induction coil system spanning the entire width of the sloping letter chute. Factory alignment procedures ensure optimum performance at all times. Visual and audible alarm indicators provide attention-getting notice of metal detected.

The LW101W is sensitive enough to detect the presence of a staple, ensuring rigid screening practices. Operation consists of allowing a suspect letter to slide across the surface chute.

If metal is detected in the letter, a visual and audible alarm will be activated. The unit is fully automatic, requiring no operator adjustment and operates on 110 VAC, 220 VAC or its own internal battery source for stand-alone, field operation, switch selectable at base of unit.

Leading Particulars

- **Construction:** 5052-H32 Aluminum chassis and stands, gray Formica®-laminated particle board side panels and letter chute
- **Power Source:** 110 VAC 60 Hz, 220 VAC 50/60 Hz, 8 "D" cell alkaline batteries
- **Dimensions:** 14" long x 12" high (mounted on stands)
- **Weight:** 10 lbs. 8 oz.
- **Circuitry:** All solid-state, balanced-induction, self-tuning, internally shielded
- **Operating Frequency:** 75 kHz
- **Alarm indicators:** Audible— Sonalert @ 96 db.; visual—green ready light, red alarm light
- **Current draw:** 100 ma.
- **Battery Life (typical):** 90 hrs.
- **Detection Sensitivity:** Minimum of 0.2 g



The LW101W letterbomb detector screens standard envelopes.



The LW101W letterbomb detector screens oversize pouches.

CATALOG NO.	DESCRIPTION	PRICE
LW101W	LETTERBOMB DETECTOR 110 VAC/BATTERY	\$595.00
LW101W220V	LETTERBOMB DETECTOR ON 220 VAC/BATTERY	\$625.00

SECTION XIII TABLE OF CONTENTS

Computer Software Systems

COMPHOTOFIT®PLUS Software 285

COMPHOTOFIT® +Color Software 286-287

Photo Identification Kits 288

Crime Scene Drawing Libraries 289

Traffic Scene Drawing Libraries 289

COMPUTER SOFTWARE SYSTEMS

Working smarter...

SIRCHIE®'s growing family of sophisticated software products offer benefits no department can afford to ignore.

Consider:

- **COMPHOTOFIT® PLUS 4.0** for DOS, a worthy successor to the enormously popular V3.0 facial identification software, is noted for composites that are often mistaken for mugshots.

- **COMPHOTOFIT® +COLOR** for Windows®, is a powerful computerized facial identification program that aids in the identification of unknown suspects. It's the latest in technology from **SIRCHIE**® which utilizes multiple databases of photographic images of facial features for use in constructing a likeness of a suspect from a witness description. Easily create startlingly realistic full color composite images of photographic quality to aid you in your department investigations.

- **Crime and traffic scene symbol libraries...** Using the precision of a CAD program and the exacting detail of our symbols libraries, you can create highly accurate and precisely scaled scene sketches in the level of detail that you desire on a PC. Each library includes numerous symbols commonly used for each type of scene drawing.

Efficiency ...

The common theme to **SIRCHIE**®'s software products is simplified operation for uniformly excellent results from officers of any skill level.

COMPHOTOFIT® PLUS FACIAL COMPOSITE SOFTWARE (MS-DOS 6.0 OR HIGHER)

comPHOTOFIT® PLUS composites are often mistaken for mugshots of people, and it's no wonder. comPHOTOFIT® PLUS employs databases of features taken from actual photographs of people, so once these features are blended together, the composite looks like a photo of a person and not a crude drawing. Don't be intimidated by comPHOTOFIT®'s amazing results, it's easy to use. It is simple with working windows, drop-down menus and dialog boxes. comPHOTOFIT® PLUS is so easy to use anyone can learn to build a photographic-quality composite in a matter of minutes. Styles change—especially hairstyles—and an agency's database must be able to change. You can create a personal database of feature and accessory images for use with the comPHOTOFIT® PLUS software with quality negatives or prints from its own file of mugshots. Personal databases not only reflect the special needs and unique ethnic diversity of your jurisdiction, but they allow an agency to keep up with the times.



These are laser printouts of composites created with comPHOTOFIT® PLUS.

Hardware and Software Requirements:

- **For running and viewing comPHOTOFIT® PLUS:**
 - IBM PC/AT (80386, 80486 or Pentium CPU or compatible)
 - 40 MB hard drive (minimum recommended)
 - 1.44 MB floppy disk drive (3.5 inch)
 - 4 MB DRAM
 - Microsoft® MS-DOS 6.0 or later, Windows® 3.1, 95, and 98, and Microsoft® or compatible mouse
 - IBM VGA color graphics adaptor or equivalent
- **For printing on plain paper:**
 - Hewlett Packard LaserJet®, DeskJet® or Epson® dot matrix compatible printer (2MB+ memory recommended)
- **For scanning images into comPHOTOFIT® PLUS:**
 - Hewlett Packard ScanJet® 256 gray shade page scanner or compatible

No. CPLS1000L consists of:

- 1-comPHOTOFIT® PLUS Software
- 1-White/Black Male Database with Image Index
- 1-White/Black Female Database with Image Index
- 1-Latino American Male Database with Image Index
- 1-User's Manual
- 1-Training Video



Mix and match the new features with the others in the purchased databases to create composites.



Capture selected features from any suitable mugshot image.

- No maintenance fees
- Lease comPHOTOFIT® PLUS for \$408.00 per year

CATALOG NO.	DESCRIPTION	PRICE
CPLS1000L	COMPHOTOFIT® PLUS FACIAL IDENTIFICATION SOFTWARE	\$1,395.00
CID300	ORIENTAL MALE AND FEMALE DATABASE	\$223.75
CID400	SURINAMESE LIGHT AND DARK SKIN DATABASE	\$223.75
CID500	MIDDLE EASTERN DATABASE	\$223.75

COMPHOTOFIT® +COLOR FACIAL COMPOSITE SOFTWARE FOR WINDOWS®

COMPHOTOFIT® +COLOR is a powerful computerized facial identification program that operates under the Windows® 3.1 (or later) operating system. It's the latest in technology from SIRCHIE®, the company which has revolutionized the composite software industry.

Like its predecessor COMPHOTOFIT® PLUS—the industry standard until now—COMPHOTOFIT® +COLOR utilizes multiple databases of photographic images of facial features. Features can be viewed on screen and assembled into startlingly realistic color or grayscale composite images.

Composites are created by combining various features in any combination from the various databases. Each database features hundreds of facial components—offering an unlimited number of possible combinations. Features can be positioned, sized, moved, copied and modified. Change individual features or the entire image. Adjust skin tones or age an image. Remove a black eye, a distracting background or add accessories, such as glasses. Use features from the expansive database or create your own (with the capture option).

Print high-resolution composites on a Windows®-supported printer (color or grayscale), fax them or export them for use in popular graphics/paint programs. Images can be printed on any Windows®-supported printer (color or grayscale). By default, composite images are printed at 3" x 4". However, images may be enlarged and printed. And a "maintain aspect" feature ensures that enlarged images are properly proportioned when printed. Before printing, you may move the composite anywhere on the page and size it to fit your specifications.

The software is compatible with a variety of Windows®-supported software applications for building and printing wanted posters with composite images.

The most exciting new option available with COMPHOTOFIT® +COLOR is the capture mode—utilizing Twain-compliant software—which gives you the ability to create your own database.

Through the capture mode, you can import your agency's mugshot images (derived from negatives, slides or prints) from a film or flatbed scanner and you can load BMP, TGA, TIFF or PCX images into a working window for further manipulation. Once you've imported the image, you can "capture" any or all of the features and accessories from that image to create a personal composite database. Using the capture feature is not only a great way to expand your existing database, but it's also a way to reflect the ethnic diversity in your community and keep your database from becoming outdated.

BUILD MODE/MAIN SCREEN

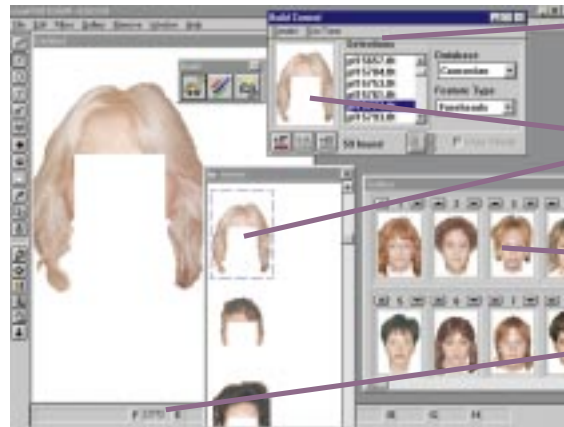

Drop down menus and dialog boxes guide you every step of the way

Preview windows allow you to see components before selecting them

On-screen candidate line-up

Component file numbers listed on-screen for easy recall

CAPTURE MODE/MAIN SCREEN



Captured features are sized automatically for compatibility with composite images

Capture an entire image (full face) or just part of it

On-screen guides make capturing features easy

Update old photos with photographic enhancement tools:

1. Eliminate Backgrounds—Remove distracting backgrounds from suspect photographs.
2. Update Old Suspect Photos and Criminal Mugshots—Project what a suspect might look like if he was a little older, had more gray hair, gained weight, even donned disguises. The capture option allows you to apply the same techniques on photographs that you used on composites.
3. Create Non-Prejudicial Line-Ups—Remove backgrounds, tattoos, scars, black eyes, bandages, bruises, sunglasses or other temporary facial abnormalities to create a non-prejudicial photo for use in your photo line-up.

PAINT MODE/MAIN SCREEN



Retouch an image with a little bit of paint or a lot—you decide

Use the clone tool to remove puzzle lines

16 million color choices

PRINT MODE/MAIN SCREEN



Select margin widths

Choose the desired width and height of the image

Give the image a border by selecting a frame width

Leading Particulars

- Hundreds of black and Caucasian male and female components (facial features) supplied
- Utilizes photographic images (not clay blobs)
- Offers maximum portability—install on laptop computers for use at locations other than the office, such as crime scenes and hospitals
- Create 24-bit color or grayscale images
- Paint tools allow you to alter images in a variety of ways—from adjusting skin tone to adding wrinkles and scars
- Forty-six brushes and a brush-bristle density option allow you to create interesting special effects, such as beard stubble
- Magnify the image up to 20x for maximum detail
- Print on any Windows®-supported color or black and white graphics printer
- Capable of printing high-resolution images
- Print “wanted posters”—with or without a border
- Composites may be printed in color and/or black and white, depending on the printer

Minimum Hardware Requirements:

- Processor: Intel 80386 or compatible
- Video Display: SVGA monitor, IBM register compatible SVGA card capable of 64K colors
- Operating System: Windows 3.1 or later
- Free Disk Space (Hard Drive): 100 MB minimum
- Memory: 8 MB (RAM) minimum
- Mouse: Microsoft mouse or compatible
- Printer: Any printer supported by Windows® and capable of graphics output.

comPHOTOFIT®+COLOR comes with:

- Software on 3.5” floppy disk, CDROM or Zip™ disk (please specify)
- Image index
- Manual
- Training Video

- Federal grants may be available to your department. Please contact us for the name of the grant coordinator in your area.
- If you're replacing your existing composite software or upgrading from comPHOTOFIT® PLUS, ask us about our upgrade incentives.

CATALOG NO.	DESCRIPTION	PRICE
CPLS1000L	comPHOTOFIT® +COLOR FOR WINDOWS	\$2,995.00
CCPLS3000L ..	comPHOTOFIT® +COLOR FOR WINDOWS WITH CAPTURE OPTION	\$3,990.00
CCID200	LATIN AMERICAN MALE DATABASE	\$895.00
CCPLS1000LL	comPHOTOFIT® +COLOR LEASE/PURCHASE OPTION	\$750.00/YEAR

PHOTO IDENTIFICATION FOIL COMPOSITE SYSTEM

The No. PIK100 is a very portable, reasonably priced, up-to-date international facial identification system. The individual facial components (acetate sheets of 0.005" thickness) are selected from photographs rather than drawings, allowing the investigator to construct the best possible likeness. No. PIK100 has 915 component foils in 13 different categories, including hair, eyes, noses, lips, chins, head ware, skin tones, eyebrows, age lines, moustaches, beards and glasses. Hair, eyes, noses, mouths and chins are supplied in both Afro and Caucasian. A selection of Oriental eyes completes the set. **SIRCHIE®** has made No. PIK100 overlay kit totally compatible with its No. PIK300 software package, allowing the No. PIK100 and No. PIK200 to be used together. Kits are supplied with sturdy carrying cases with dividers, assembly frames to hold foils in place while composites are assembled, a witness interview pad, a plotting grid, a reference guide and complete instructions.



This is a composite created with the No. PIK100 kit.



CATALOG NO.	DESCRIPTION	PRICE
PIK100	PHOTO IDENTIFICATION KIT	\$995.00
PIK1003YL	PHOTO IDENTIFICATION KIT, THREE-YEAR LEASE (PER YEAR)	\$380.00



This is a composite created with the No. PIK200 kit.

FEMALE SUPPLEMENT IDENTIFICATION KIT

The No. PIK200, a supplementary kit to the No. PIK100, consists of 183 component foils of female images and is the perfect compliment to the No. PIK100 kit. Like the No. PIK100, the No. PIK200 female supplement kit is completely compatible with its computerized counterpart (No. PIK400) and includes a sturdy carrying case with dividers, assembly frame, image index reference guide, witness interview pad, plotting grid, and complete instructions.



CATALOG NO. PIK200	FEMALE SUPPLEMENT IDENTIFICATION KIT	PRICE: \$395.00
--------------------------	--	-----------------

CRIME SCENE AND TRAFFIC SCENE CAD LIBRARIES

Computers are revolutionizing criminal investigation, making time-consuming, arduous work fast, easy and results far more professional in appearance. **SIRCHIE®** Finger Print Laboratories' crime scene drawing library and traffic scene drawing library take the technology used to produce architectural and technical drawings, and apply it to producing crime and traffic scene sketches. Working in conjunction with an agency's existing CAD software, these databases of detailed images make drawing crime and

traffic scene sketches a snap. The crime and traffic scene object libraries consist of practical, pre-drawn symbols commonly used by sketch artists. Clear, precise, neat, accurately scaled crime and traffic scene sketches may be completed in half the time by an investigator with no artistic ability.

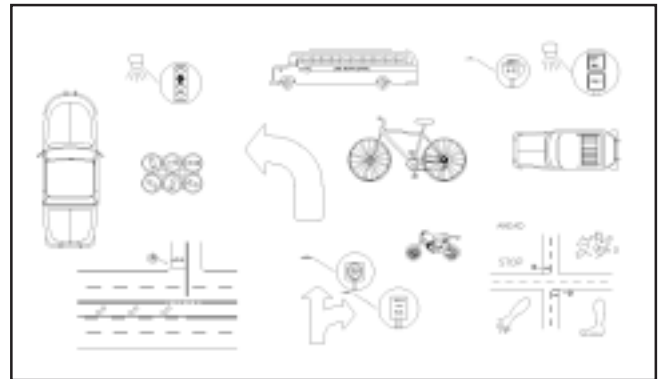
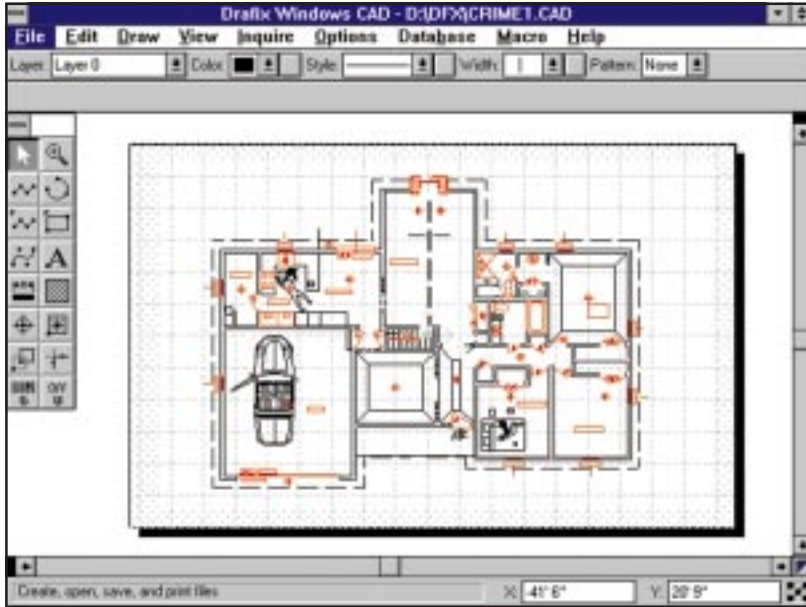

These are just a few of the symbols in the traffic scene library.

Libraries are available in the following formats:

- LB—Drafix® Windows CAD™ v3.0
- DX—for importing into any other CAD system (AutoCAD®, GenericCAD®, etc.)

Crime Scene Libraries (479 images total) include the following symbol types: bodies, furniture, guns, roads, shrubbery and vehicles.

Traffic Scene Libraries (522 images total) include the following symbol types: bodies, markers, roads, shrubbery, signs and vehicles.

Each symbol library includes:

- 1-Symbol Library on 3.5" Disk
- 1-Library Installation Guide
- 1-Library Symbol Index

Hardware Requirements:

- Minimum 15 megabytes (software and symbols)

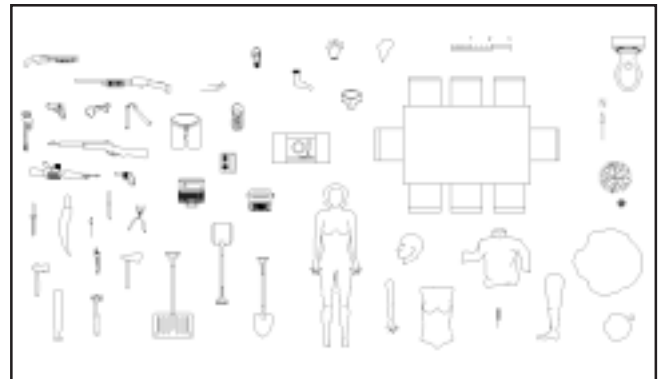

These are just a few of the symbols in the crime scene library.

Drafix® Windows CAD™ is a trademark of Foresight Resources Corp. AutoCAD® and GenericCAD® are trademarks of AUTODESK, INC.

CATALOG NO.	LIBRARY DESCRIPTION	FORMAT	PRICE
CPLS2000DX	CRIME SCENE	DXF	\$295.00
CPLS2000LB	CRIME SCENE	DRAFIX® WINDOWS CAD V3.0	\$295.00
CPLS2000SY	CRIME SCENE	DRAFIX® CAD ULTRA V4.2 FOR DOS	\$295.00
CPLS3000DX	TRAFFIC SCENE	DXF	\$295.00
CPLS3000LB	TRAFFIC SCENE	DRAFIX® WINDOWS CAD V3.0	\$295.00
CPLS3000SY	TRAFFIC SCENE	DRAFIX® CAD ULTRA V4.2 FOR DOS	\$295.00

SECTION XIV TABLE OF CONTENTS

Special Purpose Police Vehicles and Equipment

Arson Investigation Units	294-295
Accessories	307
Bomb Response Vehicle	297
Cameras, Daylight and Low Light	303
Cameras, Night Vision	303
Command Vehicle, Mobile	296
Disguises, Vehicle	307
Evidence Collection Vehicles	292-295
Interiors, Vehicle	300-301, 306
Periscopes, Manual	304
Periscopes, Motorized	302
Periscopes, Remote Control System....	303
Police Stations, Mobile	291
Prisoner Transport Vehicles	298-299
Surveillance Vehicles	300
Surveillance Systems.....	304
Video Recording Systems	305

SPECIAL PURPOSE POLICE VEHICLES AND EQUIPMENT

SIRCHIE®'s Vehicle Division provides solutions to many critical-mission vehicular needs.

Over thirty continuous years of experience in the construction of specialized police vehicles means well-thought-out, highly evolved designs and the ability to respond rapidly and efficiently to new and specialized requirements.

SIRCHIE® offers a wide range of standard vehicular systems and accessories, which feature:

Design from the chassis up—to maximize structural integrity;

Low maintenance—practical designs from an appreciation for the realities of the field;

Integration to a purpose—design from hands-on knowledge of the mission.

From the first use of unitized Fiberglas® interiors in **SIRCHIE**®'s prisoner transport vehicles to surveillance vehicles with third generation night-vision assisted video, **SIRCHIE**® innovations have become the standard others in the industry try to meet.

For any information regarding the vehicles or equipment listed in this section, contact:

SIRCHIE®
VEHICLE DIVISION
POST OFFICE BOX 789
MEDFORD, NJ 08055
PHONE, USA: (800) 545-7375
PHONE, INTERNATIONAL:(609) 654-0777
FAX: (609) 654-7869

SPECIAL PURPOSE VEHICLES

MPS9000 MOBILE POLICE STATION



A highly mobile, self-contained police station used in the inner city or in tight traffic areas. The No. MPS9000 provides a comfortable work environment in a smaller, more mobile, and economical vehicle. This unit is excellent for targeting specific neighborhoods for D.A.R.E. and other outreach programs.

All Basic Vehicles Feature:

- A reception area
- Operations area
- On-board 6.5 KW generator
- Fluorescent lighting
- 120V AC air conditioning
- 17,000 BTU propane heater
- Microwave oven
- Sink
- Filing Cabinet
- Ample storage and worktop areas

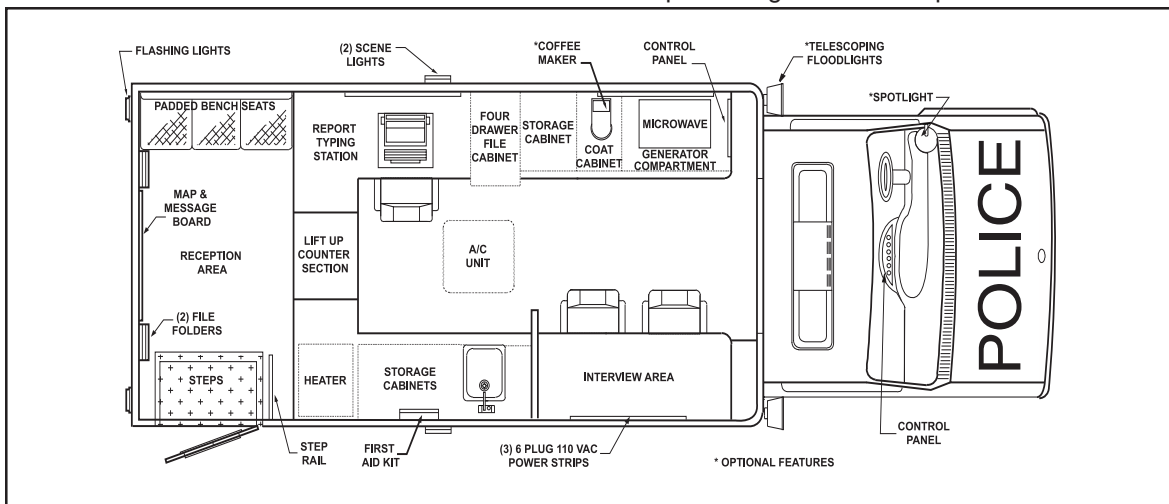

This is the view from the operations area of the No. MPS9000.



This is the view from the reception area of the No. MPS9000.

No. MPS9000 Leading Particulars

- Well-lighted operations area with convenient work stations
- Adjustable height, 360-degree padded swivel seats at the report writing area and reception counter
- Direct walk-through access to driving compartment
- Full panel, deluxe padded counter front separates reception area from operations area
- Flip-up counter leaf and swing-away doors provide access from operations area to reception area

100 SERIES EVIDENCE COLLECTION VEHICLES



VAN MODEL

No. MCL100 Leading Particulars

- High-profile, professional image, conveys authority
- Available in Ford, Chevrolet or Dodge vans
- Mobility lends itself to regional use



SUV MODEL

No. MCL100-T Leading Particulars

- Available in two- and four-wheel drive
- Accesses crime scenes larger vehicles cannot
- Self-contained unit reduces response time

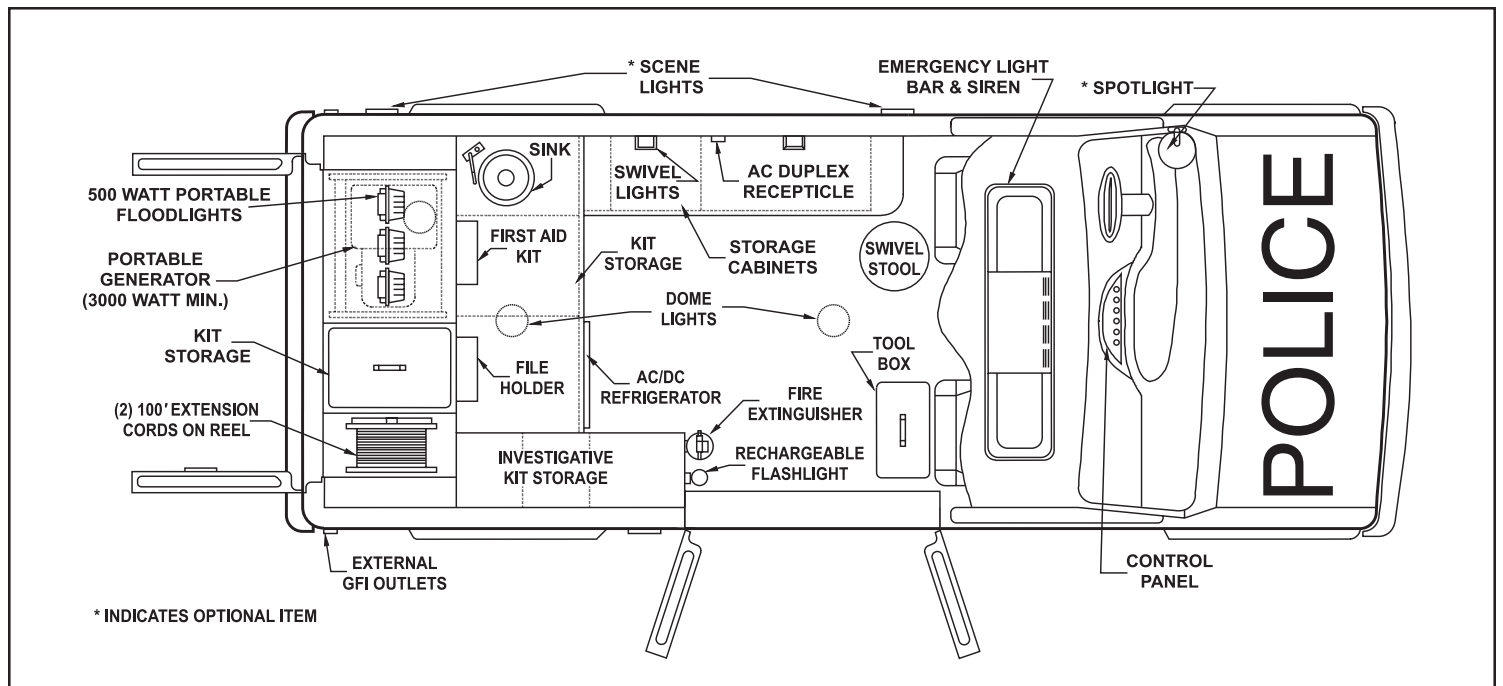

EVIDENCE COLLECTION VAN MODEL MCL100

EXPERIENCE: The Vehicle Division of **SIRCHIE®** Laboratories has produced evidence collection vehicles for departments in all 50 states as well as many foreign countries. The concepts used in the design of these vehicles are field proven as many repeat customers will attest.

VERSATILITY IN DESIGN: **SIRCHIE®**'s design staff specializes in tailoring vehicles to the individual equipment and budgetary requirements of its customers. As a fully self-contained manufacturer that produces 90-95% of all items supplied in the vehicle, Sirchie has the flexibility to construct a vehicle to meet specific requirements.

Basic Vehicle Specifications:

The 100 Series Evidence Collection Vans are supplied in a Ford (standard), Chevrolet or Dodge 3/4 ton cargo van.

Van Features:

- V-8 Engine
- Automatic Transmission
- Power Steering
- Power Brakes
- Factory Air Conditioning
- High Output Alternator
- Heavy-Duty Suspension
- AM/FM Radio

Other Available Models

For departments needing more storage space:

No. MCL100M. Extended cargo van evidence collection vehicle. The No. MCL100M features more than 20 inches of additional interior length for equipment and evidence storage.

No. MCL-100T. A more compact package for access to remote crime scenes, available with four-wheel drive.

No. MCL-10. Basic evidence collection unit in a mini-van package.

For departments with specialized needs:

SIRCHIE®'s design staff can modify the vehicle floor plan or equipment list to meet the individual departmental needs.

**LISTED BELOW IS EQUIPMENT SUPPLIED IN MAJOR CRIMES VEHICLES.
CONTACT FACTORY FOR ARSON VEHICLE EQUIPMENT LIST.**

- 1-No. MCL01 Crime Scene 35mm Photo Equipment Kit
- 1-No. MCL02 Fingerprint and 1:1 Evidence Camera with Carrying Case
- 1-No. MCL03 Professional Crime Scene Sketch Kit
- 1-No. MCL04 Investigation Mapping Kit
- 1-No. MCL05 Evidence Collection and Investigation Kit
- 1-No. MCL06 Evidence Vacuum Sweeper Kit
- 1-No. MCL07 Evidence Collection Bag and Sealing Kit
- 1-No. MCL08 Master Expert Latent Print Kit with Latent Powder, Chemical Fuming and Chemical Processes
- 1-No. MCL09 BLUEMAXX™ Patrol Kit
- 1-No. MCL10 Master Hard-Core & Liquid Silicone Casting Kit
- 1-No. MCL11 DUROCAST Impression Compound Kit
- 1-No. MCL12 Master Blood Test Kit
- 1-No. MCL13 Seminal Fluid Test Kit
- 1-No. MCL14 Trace Metal Detection Kit
- 5-No. MCL15 Primer Residue Collection Kit (Scanning Electron Microscopy)
- 1-No. MCL16 CYANOWAND™ Cyanoacrylate Fuming Kit
- 1-No. MCL17 NARK® II Narcotics Analysis Kit
- 1-No. MCL18 Number Restoration Kit
- 1-No. MCL19 Ultraviolet Kit
- 2-No. MCL20 Anti-Putrefaction Mask Kits
- 1-No. MCL21 Postmortem Fingerprint Kit
- 3-No. MCL22 Sexual Assault Crimes Investigation Kits: Victim
- 1-No. MCL23 Krime-Kit II Evidence Identification Kit
- 2-No. MCL24 4 oz. DFOSPRAY™ Amino Acid Fluorochrome
- 1-No. MCL25 Cyanoacrylate Portable Fuming Cabinet with Carrying Case
- 1-No. MCL26 Search Alert Metal Detector with Case
- 1-No. MCL27 Permanent Recovery Magnet with 225 lbs. Lift Capacity
- 1-No. MCL28 Military-Type Folding Shovel and Mount
- 1-No. MCL29 Barrier Tape: "Crime Scene-Do Not Cross"
- 1-No. MCL30 Crime Scene Tool Kit



Rear Door View



Side Door View



Cab View-Rearward

- Rear door access to generator and lighting equipment
- Portable generator to power vehicle outlets or to utilize at remote crime scenes
- Two 100-ft. extension cords on portable metal take-up reels

- Spacious interior, low maintenance floor area
- Lockable equipment and evidence storage cabinets
- Report writing desk and folder holder
- Interior 120 volt AC outlets

- Over 30 field investigation kits
- Aluminum cabinetry with compartmentalized and labeled storage areas for field kits
- On-board, self-contained sink and AC/DC refrigerator
- Well-lighted interior work area

WALK-IN VAN MODELS

The **SIRCHIE**® 900 series evidence collection vehicle fills the need for a unit that is bigger than a cargo van, without sacrificing maneuverability in heavy traffic or rural areas. It offers the roominess of a large, walk-in van, and provides the technician with expansive, well-lighted working facilities. Our design staff welcomes the opportunity to custom-tailor specifications to suit your particular needs.

Basic Vehicle Specifications:

The 900 series crime scene investigation vehicles are available on either a Ford (standard) or Chevrolet chassis. The lab area (box section of vehicle) is available in 12', 14', and 16' long models.

All Basic Vehicles Feature:

- V-8 Engine
- Automatic Transmission
- Power Steering
- Power Brakes
- Factory Air Conditioning (Cab)
- High-Output Alternator
- Bucket-Type Driver's and Passenger's Seats
- Dual Rear Wheels
- Heavy-Duty Suspension
- 10,000 pound GVWR (minimum)

No. MCL900 and No. AIU900 Leading Particulars

- Offers full standup headroom
- Direct walk-through access from cab
- Expansive worktop, sink and report writing areas
- Lockable cabinetry for equipment and evidence
- Low-maintenance, heavy-duty vinyl tile flooring



This is a view inside the No. MCL900 from the rear doors.

MOBILE CRIME LAB 900



ARSON INVESTIGATION UNIT 900



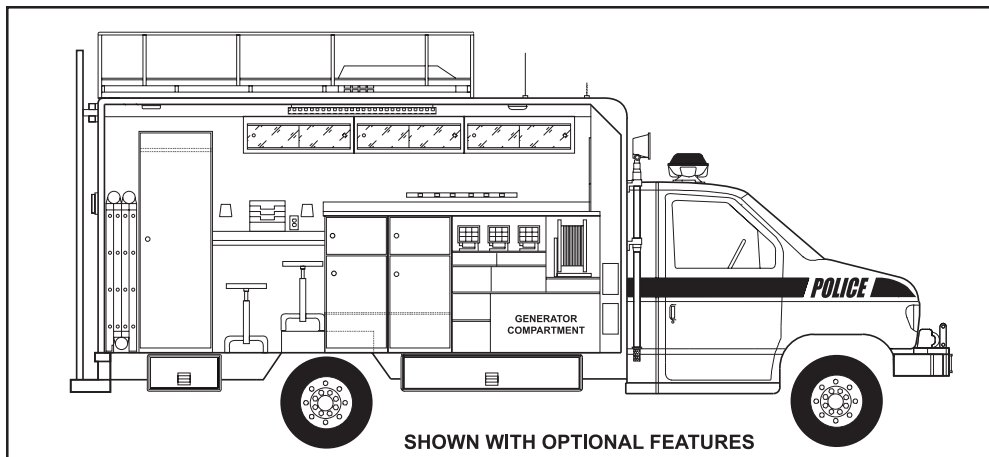

This is an interior view of the No. MCL900 from the passenger's side.

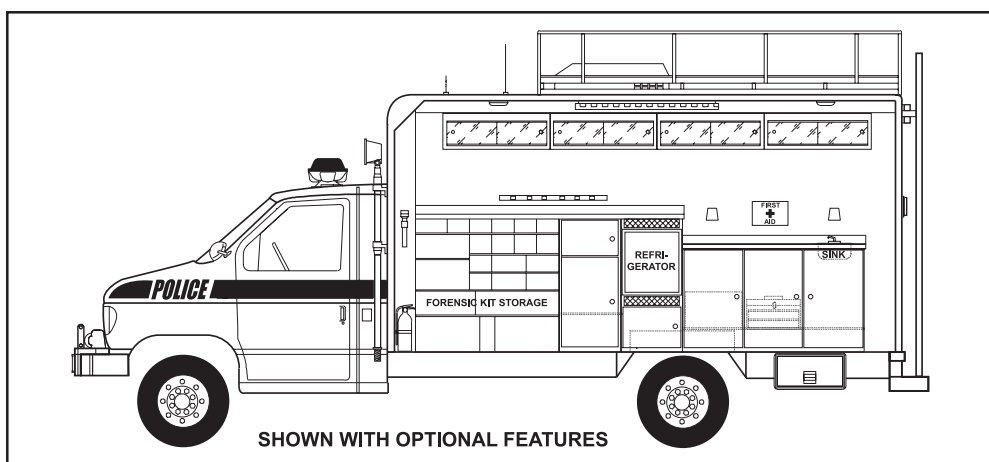

This is an interior view of the No. MCL900 from the driver's side.

TRAINING:

Included with any **SIRCHIE®** evidence collection vehicle is a training program on the use of the vehicle and its on-board systems.

- A list of standard field kits supplied in major crime scene units is shown on page 293
- Contact factory for arson vehicle equipment list
- Full, detailed specifications or custom-tailored designs



This is the interior of the No. MCL900 viewed from the passenger's side.



This is the interior of the No. MCL900 viewed from the driver's side.

No. MCL900 and No. AIU900 Leading Particulars

- Sound-dampened generator compartment
- On-board commercial/industrial generator, with remote push-button start/stop switch
- Three portable 500-watt floodlights
- Permanently labeled field kits stored in compartmentalized storage cabinets
- All shelves lined with slip-resistant and noise-suppressing corrugated rubber matting
- Custom-designed storage available to accommodate existing department equipment

SPECIAL PURPOSE VEHICLES

MCV9000 MOBILE COMMAND VEHICLE



A maneuverable mobile command platform to handle all types of emergency situations. The goal with the **SIRCHIE**® MCV9000 is to provide an operational command and communications center at the emergency scene. The heavy-duty chassis provides longevity without the need for special driver training or licensing. How effective is a command center that cannot reach an incident scene because of rough terrain or severe weather? Unlike larger mobile home and bus chassis, the more manageable size of the MCV9000 with optional four-wheel drive provides unmatched access to remote emergency scenes.

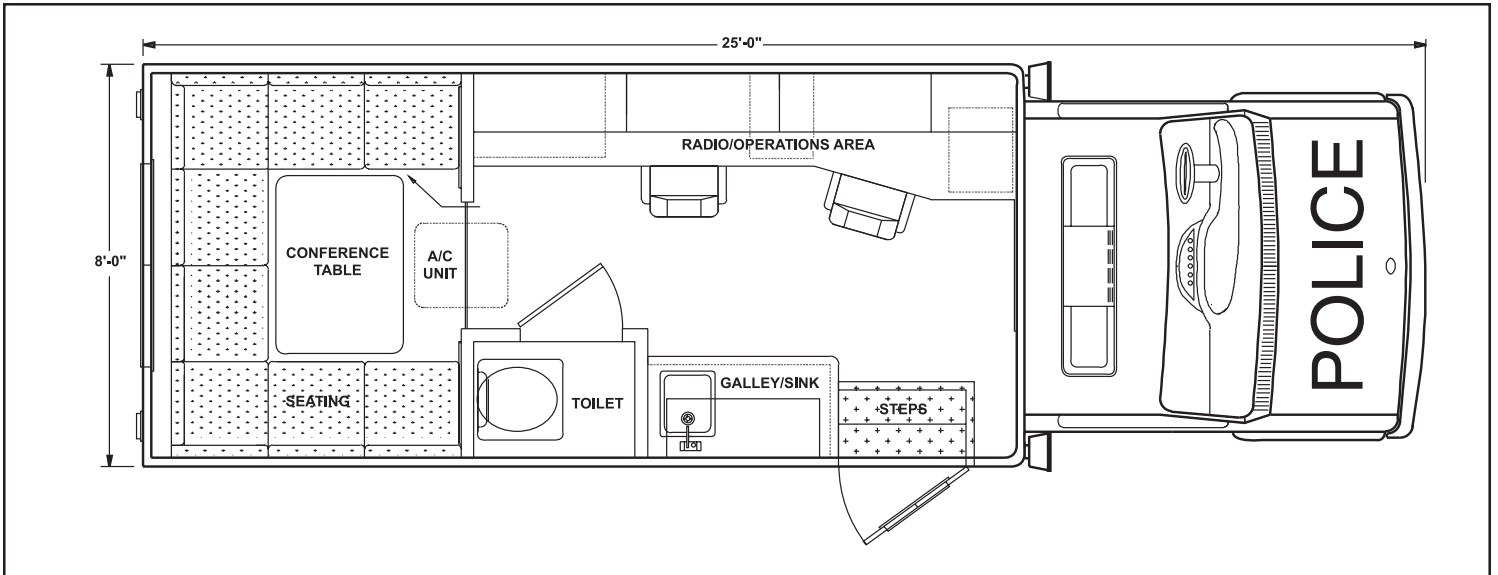

Standard Equipment:

Ford super-duty cutaway chassis • 25-ft. overall length • Fuel injected V-10 engine • 14,000 lb. GVWR • Emergency lighting
Air-conditioning and heating • Fluorescent lighting • On-board generator • Interior and exterior AC outlets • Shore power connections • Radio area • Conference area • Storage cabinetry • Map and drawing boards • Flushing toilet • Galley/Sink

Optional Equipment:

RV-style awning • Observation roof deck • Bumper mounted winch • Four-wheel drive • Telescoping floodlights • Cellular phone
Exterior storage compartments • Periscope Video monitoring system • Microwave • Refrigerator • Window package

ALTERNATE FLOOR PLANS AND CHASSIS AVAILABLE, CONTACT OUR FACTORY FOR DETAILS

BRV9000 BOMB RESPONSE VEHICLE



An unmatched mobile platform to handle all types of bomb response situations. The goal with all **SIRCHIE®** vehicles is to get the technician and all necessary equipment to the scene in an efficient manner. Compartmentalized storage compartments allow quick access to needed equipment. Compartments constructed with steel framing strength and baked on enamel paint provides a lifetime of service. Heavy-duty hinges and vise action positive locks keep equipment secure while in route.

A 13,500 BTU roof-mounted air conditioner and a 1,500-watt space heater keeps the interior comfortable. There is 14-feet of countertop workspace plus a 4-foot operations desk. 125 Square feet of cabinet space and a dedicated storage area for a customer supplied bomb robot.

The 4,500-watt on-board generator features an electric start with a convenient remote switch. The generator draws fuel from the vehicle's tank and provides power for outside GFI protected outlets, several interior power outlets, fluorescent lighting, climate control and any installed 110-volt accessories.

Standard Equipment:

Ford super-duty chassis • 14-ft. lab area • fuel-injected V-8 engine • 10,700 lb. GVWR • Lightbar & Siren • Scene lights • Roof mounted 13,500 BTU air conditioner • 1,500 watt heater • fluorescent lab area lighting • 4,500 watt generator • Interior and exterior 110-volt outlets • Portable flood lights • Extension and dockside cords • Rechargeable flashlight • Steel-framed storage cabinets with baked-on enamel paint • formica laminated cabinet doors with continuous stainless steel hinge • Operations desk with storage drawers • Countertop workspace • Storage area for customer supplied bomb robot • Fire extinguisher • First-aid kit

Optional Equipment:

Observation roof deck • Ladders • Four-wheel drive • 8,000 lb bumper-mount winch • Cellular phones • Radio systems and installation • Body-mounted telescoping flood lights • Portable telescoping flood lights • Exterior storage compartments • RV-style awning • 6,500 watt generator • Overhead storage cabinets • Scene camcorder • Monitor and VHS player • Hydrocarbon detector • Forensic Optical Comparator • Map & message boards • "Light Box" rechargeable flashlights • Class IV hitch for bomb bucket • Curb side door

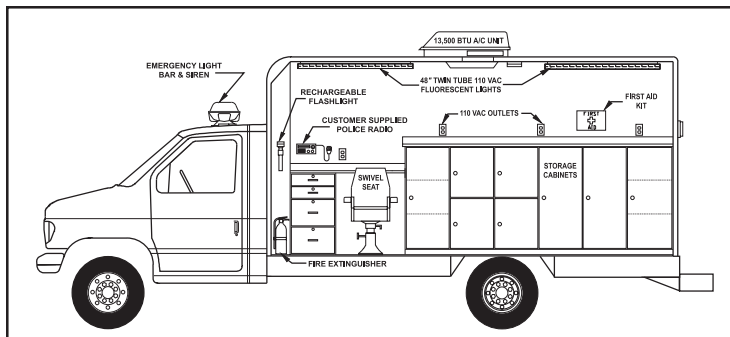
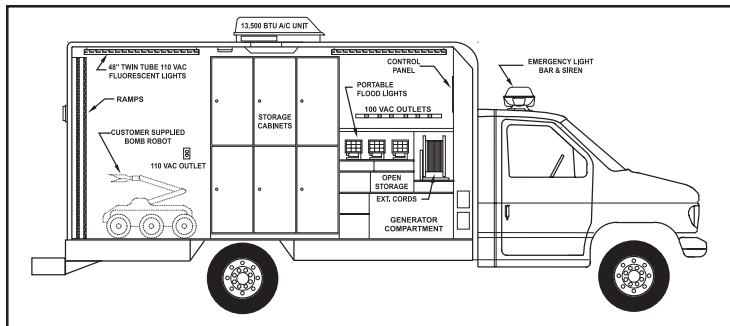

PRISONER TRANSPORT VEHICLES



PRISONER TRANSPORT VEHICLE 100

The No. PTV100 Fiberglas® prisoner transport system was introduced by **SIRCHIE®** in 1979 and today has become the prisoner transport system of choice by departments throughout the world.

The unitized Fiberglas® interior provides maximum security of prisoners in an easy-to-clean and maintain prisoner confinement area. The durable, steel-reinforced Fiberglas® bulkhead that separates the driver from prisoners in conjunction with the inner security door provides unmatched officer safety.

Alternate floor plans for the PTV100 are available to accommodate any department's exact needs. Segregated prisoner cells, minimum security cells, K-9 compartments and S.W.A.T. compartments all can be incorporated into the basic floor plan.

No. PTV100 Leading Particulars

- Maximum officer safety and prisoner security
- 1/2" thick Lexan observation window
- Fiberglas® interior can be easily washed and disinfected
- Unitized construction eliminates the hiding of contraband and weapons
- Positive, two-point locks on security doors
- Well lighted prisoner area with unbreakable lights
- Flow-through ventilation
- Heavy-duty bumper step with lights
- Contoured fiberglas® modules provide maximum utilization of space
- Emergency exit door in cab bulkhead
- Optional center divider for segregation of prisoners
- Optional air-conditioning and heating systems



Inner security door provides maximum security and safety. This is a standard feature on the PTV100.



Optional dual inner security door allow for better control when unloading prisoners from the PTV100. (Option No. PTV-6)

PRISONER TRANSPORT VEHICLE MODEL PT100

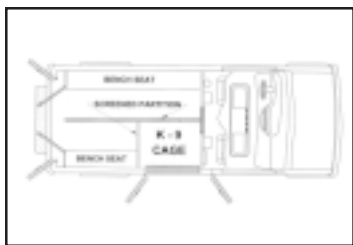
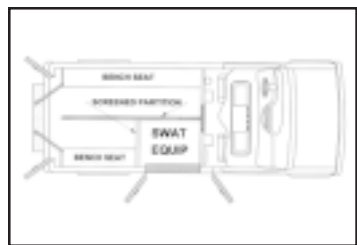
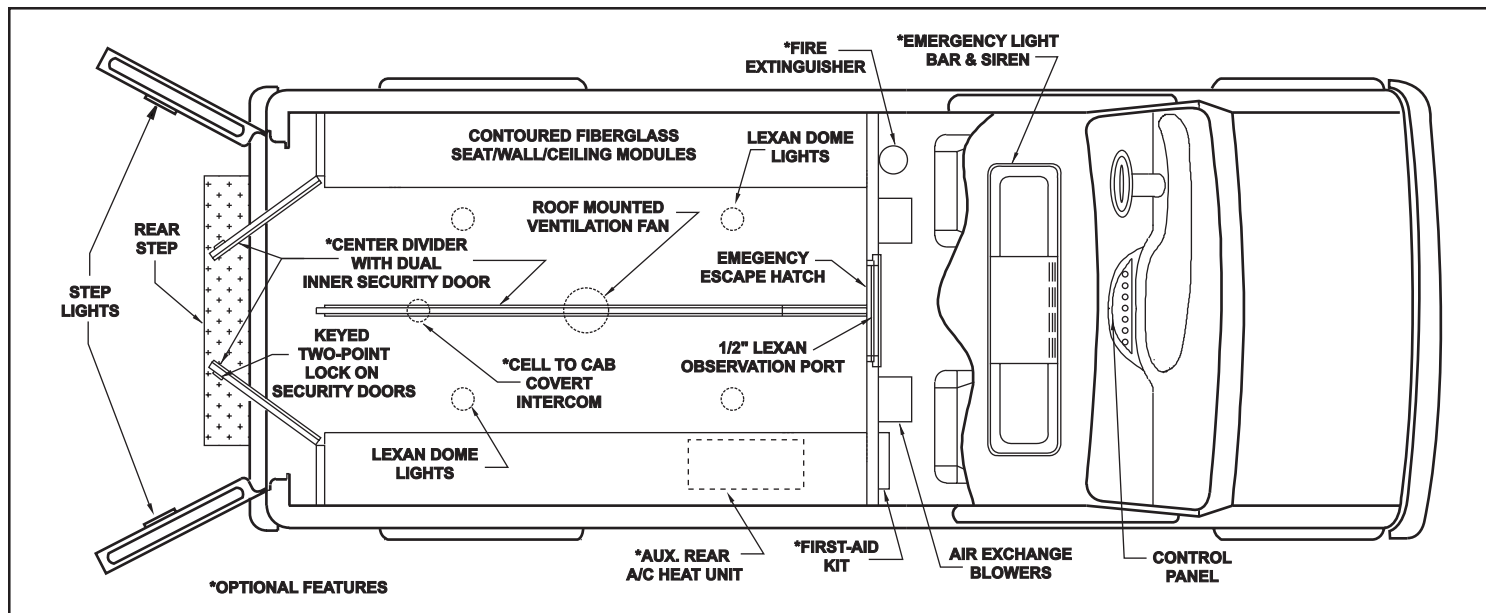

Optional Features:

- No. PTV1 Emergency Light Bar
- No. PTV2 Full Function Siren
- No. PTV3 Two-Way Intercom
- No. PTV4 Auxiliary Rear Heater
- No. PTV5 Auxiliary Rear Heater and Air Conditioner
- No. PTV6 Center Divider and Double Rear Doors
- No. PTV7 Security Door Alarm
- No. PTV8-10 Auxiliary Compartments for various needs

**PTV100M AND PTV900
EXTENDED PRISONER TRANSPORTS**

Constructed of the same durable Fiberglas® material, the No. PTV100M (not pictured) and the PTV900 Walk-In are ideal for departments that require additional prisoner capacity. A typical PTV100 seats ten prisoners, a PTV100M seats twelve prisoners and the PTV900 Walk-In seats fourteen prisoners.



SURVEILLANCE VEHICLES

MSV200



Leading Particulars

- Contractor-look van fits in any neighborhood
- Optional magnetic signs and stripes change the look from day to day
- Heavy-duty suspension allows movement within the vehicle without detection
- Optional ladder rack hides periscope

MSV200RV



Leading Particulars

- Recreational-look van for upscale neighborhoods
- Fiberglass raised roof allows for mounting of hidden antennas
- Extra headroom around periscope
- Excellent second/alternate vehicle look

FULL-SIZE VAN INTERIOR

Custom-Crafted Interiors—Space inside a surveillance van is limited and to provide a comfortable work environment it must be utilized to its fullest. All **SIRCHIE**® van interiors are individually designed to house the specific equipment in an ergonomic manner. By avoiding the use of rack mount systems, our custom manufactured interiors provide unmatched operator comfort. A must for long-term surveillance.



Leading Particulars

- Lowest profile motorized periscope with continuous 360° rotation—no preset stopping points
- Unmatched optic range made possible by true optical quality mirrors and telephoto lensing in excess of 500mm.
- Stainless steel below floor battery compartment provides for more interior space

MINI VANS AND SPORT UTILITY VEHICLES ARE ALSO AVAILABLE

SURVEILLANCE VAN INTERIORS

The most spacious and comfortable work interior available

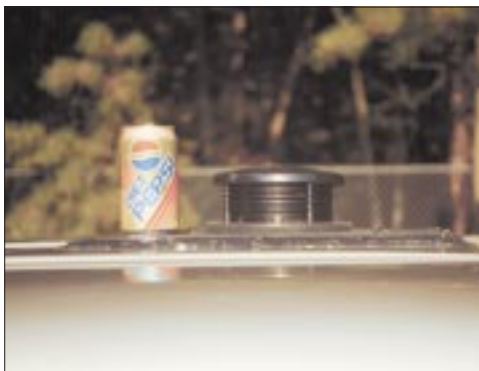
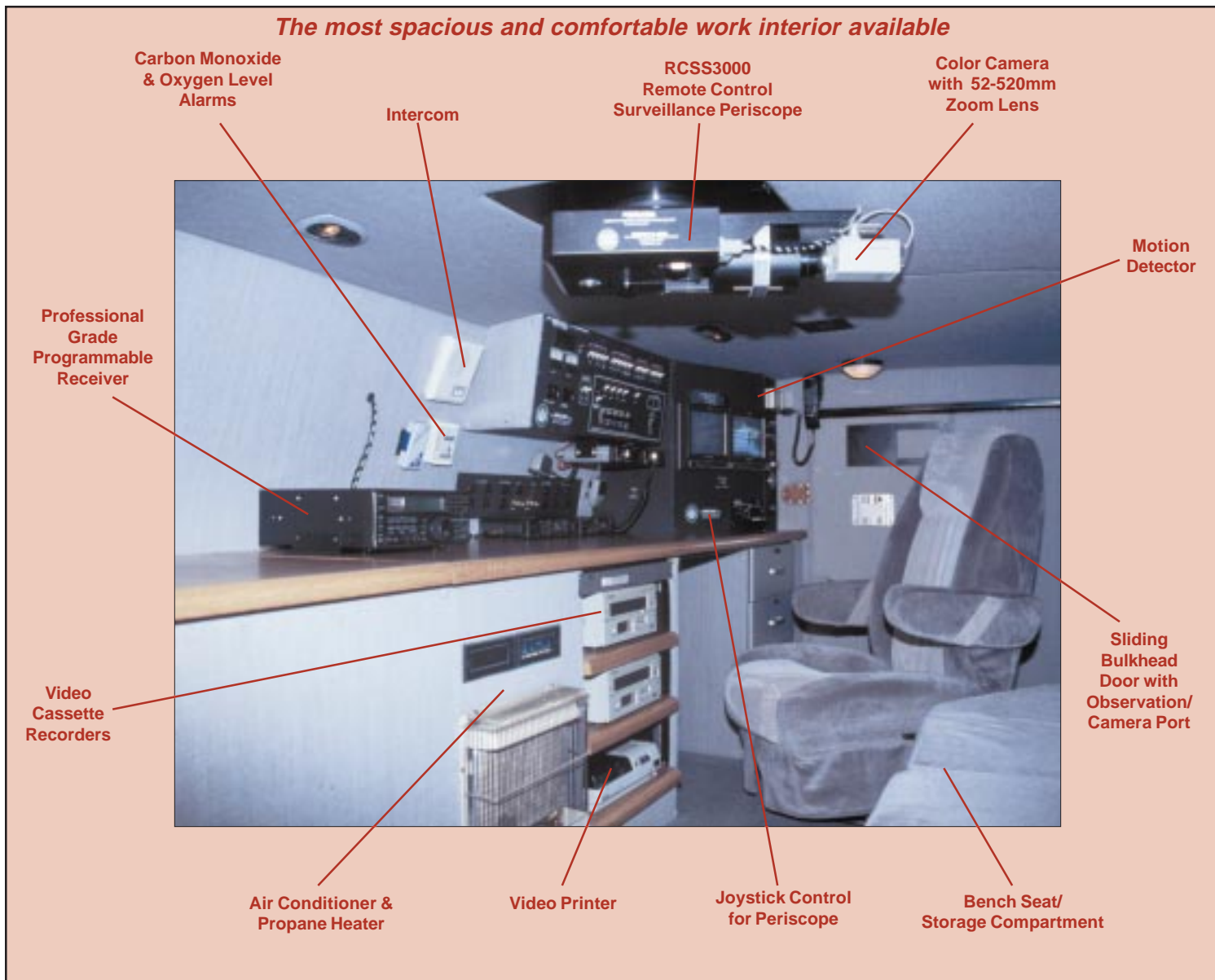

New lower profile—protrudes only 3" above roof line



Fast 15-second changeover reduces lost video while changing from day to night cameras



Graduated speed joystick controls all periscope and camera functions

MOTORIZED PERISCOPE SYSTEM

MOTORIZED PERISCOPE SYSTEM

SIRCHIE®'s motorized periscope combines ease of operation through the use of a unique hand-held controller with unparalleled results due to the use of optic mirrors.



New lower profile—protrudes only 3" above roof line

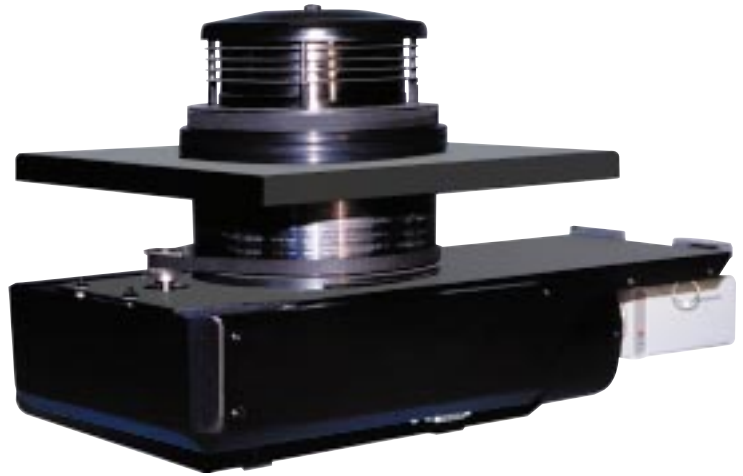

Periscope



15-second changeover



Hand-held joystick controller

The graduated speed feature provides full range control of the periscopes movement. From a slow crawl for smooth video at high magnification to full speed for following a running suspect or moving car, the graduated speed feature provides unparalleled control of your video recordings.

Leading Particulars

- Full 360° turret-type design
- Disguised as low profile static vent
- Does not have to be raised or lowered—eliminating the risk of detection
- Compact, hand-held joystick controller with graduated speed and turbo features
- Available camera systems equipped with modified motorized lenses—simply plug in and use
- Optic-quality mirrors provide distortion-free imaging with lenses in excess of 500 mm
- Corrosion-proof construction of aluminum and stainless steel
- Retractable lens and mirror guard

CATALOG NO. RCSS3000 MOTORIZED PERISCOPE SYSTEM PRICE: \$3,995.00

PERISCOPE CAMERAS

PERISCOPE CAMERAS



DELUXE DAYTIME COLOR CAMERA

No. DCX300

Leading Particulars

- 480 lines of resolution
- 1/3" CCD chip
- Professional Grade 16-160 mm zoom lens f1.8
- Installed 2X extender gives effective range of 52-520mm



LOW LIGHT COLOR CAMERA

No. DCX200

Leading Particulars

- 330 lines resolution
- 1/3" CCD chip
- Professional Grade 16-160 mm zoom lens f2.2
- Installed 2X extender gives effective range of 52-520mm

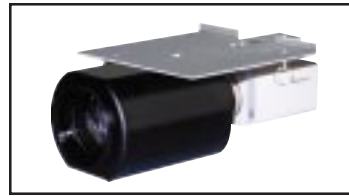

BLACK & WHITE LOW LIGHT CAMERA

No. LLC1000

Leading Particulars

- 570 lines of resolution
- 1/3" CCD chip
- Professional Grade 16-160 mm zoom lens f2.2
- 0.06 lux rated at f1.2

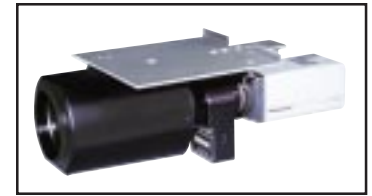

3RD GENERATION NIGHT VISION

No. NSC3000

Leading Particulars

- 18mm intensified tube
- Minimum illumination of 0.00001 lux required
- Professional Grade 16-160 mm zoom lens f2.2
- Dedicated black and white camera

CATALOG NO. DCX300 DELUXE DAYTIME COLOR CAMERA PRICE: \$3,164.00

CATALOG NO. DCX200 LOW LIGHT COLOR CAMERA PRICE: \$2,164.00

CATALOG NO. LLC1000 LOW LIGHT BLACK & WHITE CAMERA PRICE: \$1,495.00

CATALOG NO. NSC3000 3RD GENERATION NIGHT VISION CAMERA PRICE: \$5,990.00

REMOTE PERISCOPE CONTROL SYSTEM



SIRCHIE[®]'s "RF" remote periscope control system allows the periscope and camera in a surveillance vehicle to be activated and controlled from a remote location. This system eliminates the need to have an operator in the vehicle—therefore saving valuable man-hours. The vehicle can now be placed in a area hours before the "action" takes place, greatly reducing the chance of detection. At the appropriate time, the equipment is activated and the video transmitted to the control site and recorded. The remote periscope controller actuates all functions including pan, tilt, zoom, focus and iris settings. System is addressable allowing multiple transmit sites to be operated from a single controller.

CATALOG NO. RPCS1000 REMOTE PERISCOPE CONTROL SYSTEM PRICE: \$16,990.00

MANUAL PERISCOPES AND PORTABLE SYSTEMS

COMPACT MANUAL PERISCOPE

Universally adaptable to all camera systems, **SIRCHIE®** offers a compact manual periscope for those agencies looking for simplicity, function and durability. This economical unit is compatible with 35mm, digital and CCTV cameras with lensing in excess of 500mm. This is accomplished through the use of the same high quality optical first surface mirrors as found in the deluxe motorized periscope system.

No. CMP1000 Leading Particulars

- Disguised as a circular "static vent" (4" H x 6" Dia.)
- Does not have to be raised to be utilized
- Compact interior turret extends only 10" below ceiling level
- Machined aircraft aluminum & stainless steel ball bearing construction for years of maintenance free use.
- Upper and lower mirrors are fully adjustable, Optic Quality first surface, double coated with enhanced aluminum which provide sharp distortion free images
- Supplied with horizontally adjustable heavy duty camera mounting arm



CATALOG NO. CMP1000 COMPACT MANUAL PERISCOPE PRICE: \$1,690.00

PORTABLE SURVEILLANCE SYSTEM

Rented and seized vehicles become an instant surveillance platform with **SIRCHIE®**'s portable surveillance system. This cost-effective unit provides results comparable to a surveillance van. Ideal for agencies who need a constant change in appearance or who are working with a tight budget. Optional pan & tilt unit with joystick controller and color camera, can be mounted at a vehicle window or on the side of the portable surveillance system.

No. PSS100 Leading Particulars

- Sized for use in mini-vans and sport utility vehicles
- Fully equipped with monitor, time lapse VCR with time & date, Icom scanner and Marantz audio cassette recorder
- Deep cycle, gel cell battery and built-in battery charger
- Dedicated power and video jacks for expansion and back-up recordings
- Four 12-volt connections for powering external accessories
- Sturdy integral support handles, easily carried by two people
- Low profile design for below window concealment
- Approximate size: 36"W x 24"H x 22"D, weight: 175 lbs.



CATALOG NO. PSS100 PORTABLE SURVEILLANCE SYSTEM PRICE: \$6,950.00
CATALOG NO. PTC200 PAN & TILT W/ JOYSTICK AND COLOR CAMERA PRICE: \$3,990.00

SPORT UTILITY VIDEO SYSTEM

The SUV1000 surveillance system is designed to be used in today's popular sport utility vehicles. The two-part system includes a disguised camera module that is placed in the vehicle cargo area. This unit operates like a periscope and features interchangeable cameras for use in day or night operations. The camera looks out the top of the unit through the vehicle side glass. Adjustable legs allow the unit to be raised and lowered to fit different vehicles or to allow viewing over parked cars.

The control unit consists of a hard shell briefcase with internal joystick-style camera control, a 6.4" LCD flat screen monitor, time and date generator and a VHS video recorder. Controller is hardwired to the camera module via a supplied 20-ft. umbilical cord. A wireless remote control system is also available.

System is supplied with a color camera and 32-320mm zoom lensing. Alternate and additional camera systems are available.



CATALOG NO. SUV1000 SPORT UTILITY VIDEO SYSTEM PRICE: \$9,450.00
 CATALOG NO. RFC1000 RF-VIDEO AND CONTROL SYSTEM OPTION PRICE: \$16,990.00

VIDEO MONITOR AND RECORDING SYSTEM



No. VMR2000S Leading Particulars

- Professional video system designed for rugged surveillance vehicle use
- All metal housings and circuitry designed for extreme temperature conditions
- Time lapse VCR with built-in time/date generator for evidential recording
- 12V DC cigarette plug and video cables included
- Portable racks for quick and easy storage or alternate uses
- Components can be purchased separately and are supplied with mounting brackets
- Available in stacked or side-by-side versions

VCR Leading Particulars

- 4-Head VHS high-resolution unit with 2- and 6-hour real-time recording and 12/24-hour time-lapse recording
- Noiseless still, forward/reverse search

Monitor Leading Particulars

- Studio-quality color monitor for sharp, vivid pictures
- Built-in audio speaker allows monitoring of bodywire transmissions

CATALOG NO.	DESCRIPTION	PRICE
VMR2000S	STACKED VIDEO SYSTEM	PRICE: \$2,499.00
VMR2000	SIDE-BY-SIDE VIDEO SYSTEM	PRICE: \$2,395.00
VCR2000	VCR ONLY W/MOUNTING BRACKETS	PRICE: \$1,190.00
PCM2000	COLOR MONITOR W/MOUNTING BRACKETS	PRICE: \$1,195.00

SILENT WET ICE A/C SYSTEM

No. AC43W Leading Particulars

- System does not require vehicle to be running
- Formica finished worktop
- Increased capacity, all stainless steel cooling chamber will not rust or corrode
- High output 12V DC powered, sound-dampened blower motor
- Supplied with thermostat kit and interior food and beverage tray
- Easily accessible water and condensation drain valves
- Housed in attractive panel finished cabinet that nests over van wheel well



CATALOG NO. AC43W PRICE: \$2,395.00

BENCH SEAT



No. PBS1000 and No. PBS2000 Leading Particulars

- Two-piece modular bench seat for mounting over wheel well area of cargo vans
- Provides additional seating and storage space in van
- Removable, padded cushions available in automotive fabric or soft black leatherette

CATALOG NO. PBS1000 PRICE: \$275.00

LEATHERETTE-COVERED

CATALOG NO. PBS2000 PRICE: \$295.00

FABRIC-COVERED

ELECTRIC HEATER

No. BSH100 Leading Particulars

- 12V DC powered
- Does not require vehicle to be running
- Compact design
- Can be used to augment hot water heater on extended surveillance or by itself



CATALOG NO. BSH100 PRICE: \$195.00

OSCILLATING FAN

No. OSF100 Leading Particulars

- Oscillates in 180-degree arc or can be set stationary anywhere in the arc
- Supplied with wall mount for ease of installation
- Compliments air conditioner by moving cooled air
- 12V DC powered



CATALOG NO. OSF100 PRICE: \$69.00

BLACK-OUT/PRIVACY CURTAIN

No. PC10 Leading Particulars

- Two-panel black curtain with vertical velcro fasteners to secure panels closed
- Supplied with easy to install curtain track with nylon glides and may be mounted to wall or contoured to ceiling
- Designed for full size cargo vans, mini vans and speciality versions available

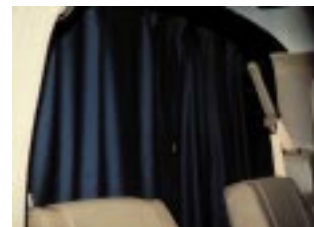

CATALOG NO. PC10 PRICE: \$169.00

CARBON MONOXIDE ALARM

No. CMA100 Leading Particulars

- 12V DC powered unit for operation from vehicle electrical system
- Detects presence of carbon monoxide
- Sounds audible alarm
- Recommended for officer safety in vehicles that may sit and idle or which are very airtight



CATALOG NO. CMA100 PRICE: \$159.00

ACCESSORIES

- **1. No. VMD1000 Video Motion Detector.** Unit automatically alerts operator when motion is detected. Operates off 12V DC.
CATALOG NO. VMD1000 VIDEO MOTION DETECTOR PRICE: \$650.00
- **2. No. INV250 & INV1000 Power Inverters.** Converts battery power to 110-volt AC, required for video printers.
CATALOG NO. INV250 250-WATT POWER INVERTER PRICE: \$199.00
CATALOG NO. INV1000 1000-WATT POWER INVERTER PRICE: \$748.00
- **3. No. PS200 Periscope Sock.** The sock eliminates light transfer out of the vehicle and reduces the loss of heat or air conditioning through the periscope.
CATALOG NO. PS200 PERISCOPE SOCK PRICE: \$65.00
- **4. No. MA200 Magic Arm Camera Mount.** This mount features a fully articulated arm with 90° pivotable and 360° rotatable ends. Supplied with door mount clamp receiver.
CATALOG NO. MA200 CAMERA MOUNT AND RECEIVER PRICE: \$199.00
CATALOG NO. DM2 RECEIVER ONLY PRICE: \$59.00
- **5. No. VP1000 Black and White Video Printer.** (Requires 110-volt power inverter, sold above.)
CATALOG NO. VP1000 BLACK AND WHITE VIDEO PRINTER PRICE: \$1,695.00



WINDOW AND EXTERIOR DISGUISE SYSTEMS

- **1. No. TR1000 Trades Rack.** This specially designed lightweight rack with pipe can be installed or removed for disguise in minutes.
CATALOG NO. TR1000 TRADES RACK (LADDER NOT INCLUDED) PRICE: \$349.00
- **2. No. MAG2000 Magnetic Signs.** These signs quickly change the appearance of a surveillance vehicle.
CATALOG NO. MAG2000 MAGNETIC SIGNS/SET OF TWO PRICE: \$135.00/SET
- **3. No. MAG1000 Magnetic Stripes.** These stripes quickly change vehicle appearance.
CATALOG NO. MAG1000 MAGNETIC STRIPES/SET OF TWO PRICE: \$125.00/SET
- **4. No. BP1 and No. BP2 Van Window Insulated Black-Out Pads.** Black-out pads are made of an opaque black cloth which prevents viewing into van. It is also thermally insulated to reduce temperature extremes inside the van. Available with or without a camera port.
CATALOG NO. BP1 PAD WITH CAMERA PORT PRICE: \$99.00
CATALOG NO. BP2 PAD WITHOUT CAMERA PORT PRICE: \$89.00
- **5. No. PTP1000 Removable Plexiglas Privacy Tint Panels.** These dark tint privacy panels permit photographing through van windows without detection.
CATALOG NO. PTP1000 PRIVACY TINT PANELS/SET OF TWO PRICE: \$179.00



What is Reflective Ultraviolet Imaging?

We see, or are able to image an object either because it emits light or because it reflects light incident upon it.

Objects that reflect light do so in a characteristic manner: they may reflect strongly or weakly, specularly or diffusely, and they may reflect some colors and not others.

For example, the sunlight impinging on a healthy leaf is made up of all visible colors. The leaf will absorb most of the colors, but will strongly reflect a particular range of colors back to our eyes, which is, of course, why it appears green to us.

Other objects reflect other colors. It is differences in the reflective properties of materials that allow us to distinguish objects that do not emit their own light.

Such differences in reflectance extend to most materials and to most wavelengths of radiation. Our eyes easily detect subtle differences in reflectance in the visible light wavelengths.

But there are wavelengths that our eyes do not see. Instruments designed to see in those wavelengths show us the world in a new perspective.



▲ 1. Magazine cover photographed in natural light—NO visible latent prints



◀ 2. View of the same magazine cover as it appears in the *KRIMESITE*™ SCOPE eyepiece without the UV filter in place

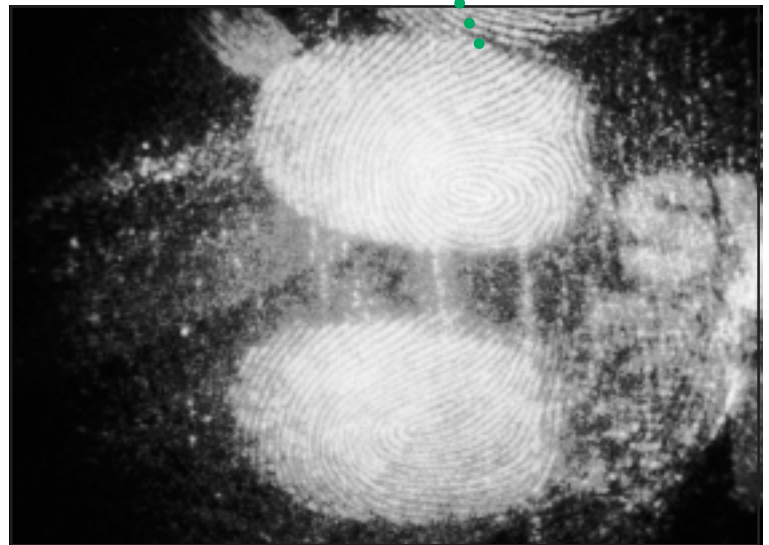

▲ 3. View of the same area of the magazine with the *KrimeSite*™ SCOPE, shortwave (254 nm) light source and UV filter in place

Leading Particulars:

- Real-time imaging—day or night—indoors or outdoors.
- Latent print visualization on most non-porous surfaces before any powder, chemical or vapor treatment
- Enhanced imaging of cyanoacrylate fumed latent prints without dye staining or fluorescent powder application, especially on multi-colored backgrounds
- Real-time photography with film
- Capture images on videotape or floppy disk for reproduction, retrieval transmission and enhancement as required
- Luminol-treated blood prints and blood traces, foot- and shoeprints (dust) and more

Film type: Kodak® TMAX P3200 ISO Black and White Print Film
Exposure: f 2.4 @ 1/125 sec.

The *KRIMESITE*[™] SCOPE Function...



A. Cyanoacrylate-fumed soda can

Examination using a RUVIS is similar to examination using reflected visible light or oblique illumination techniques with the exception that contrast between the object of interest and the surface it is on is greatly enhanced. Although sensitive to the relative angles between light, target and viewing device, contrast enhancement is good enough even at non-optimum angles to allow you to easily locate invisible fingerprints across a room.

With its auxiliary attachments, the *KRIMESITE*[™] SCOPE allows for the easy recording of latent prints without treatment either using film cameras (exposure times on the order of 1/125th second with Kodak[®] TMAX P3200 black and white film) or video cameras and videotape.

An available chronicle camera can be selected to record the crime scene, while a built-in microphone allows for descriptive annotation in real time.

Use of the *SIRCHIE*[®] *KRIMESITE*[™] SCOPE...

will give exceptional reproduction of latent prints fumed with cyanoacrylate glue without the use of “dye-staining”, “lasers”, or “alternate light sources.”



B. Close-up photo of fumed print (only partially visible due to background)

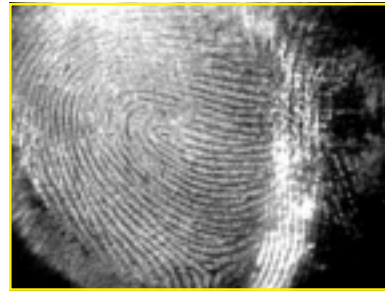

C. Close-up photo with *KRIMESITE*[™] SCOPE (background disappears and full latent print recorded)

KRIMESITE[™] SCOPE progressive photographs of latent print evidence without cyanoacrylate fuming.

▼ A. Target Object



▼ B. Target Object Close-Up



▼ C. *KRIMESITE*[™] view of “B”

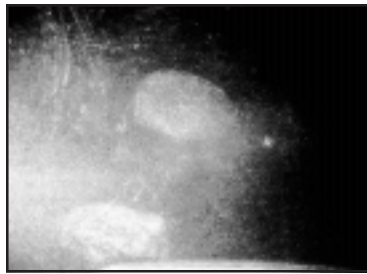

▼ D. *KRIMESITE*[™] Close-Up View of “C”

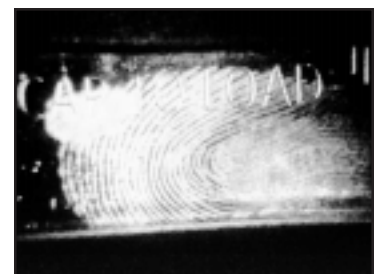
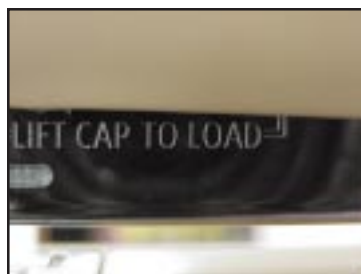
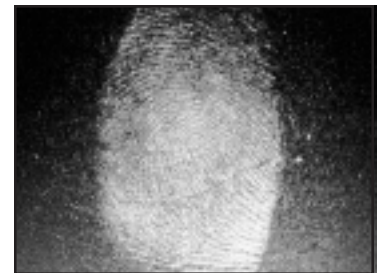
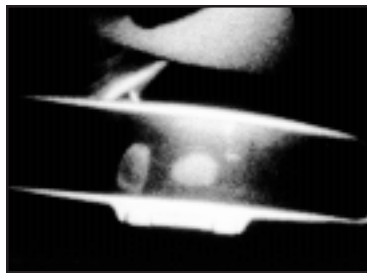
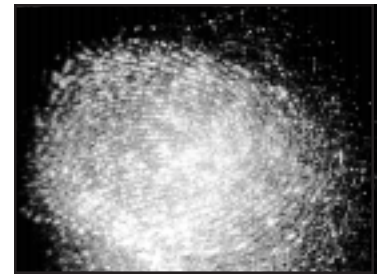

Regarding the Basic Direct View **KRIMESITE™** SCOPE...

Using a shortwave UV source, the crime scene is rapidly and easily searched for prints on non-porous surfaces utilizing this instrument. No need to control environmental lighting because this instrument needs only the illumination from your UV lamp, and ignores all other illumination.

Daylight or darkness, locating and recording prints is rapid and efficient. All **KRIMESITE™** Scope variations include this basic **KRIMESITE™** Scope. Evidence developed using the scope can be recorded using a film camera with the included camera adapter.

Other accessories, including the **KRIMESITE™** Scope video camera, can be added at any time.



No. KSS1001 Direct Viewing



No. KSS1001 with quick-connect camera adapter and 35mm camera attached

Resultant photograph of unprocessed magazine cover (Kodak TMAX P3200 @ 1/125 second)



the Basic Direct View **KRIMESITE™** SCOPE

No. KSS1001 Specifications:

OPTICS:

- Nikon® 105mm quartz element lens with modification, capable of close-up and crime scene photography without swapping optics
- Field of View: 12 in. (30.5 cm) at 49 in. (125 cm) 65% more field than standard Nikon® 105mm lens
- Magnification: Full frame image of a fingerprint at 3.75 in. (9.5cm) 60% greater magnification than standard Nikon® 105mm lens
- Spectral Range: 225 nm to infrared
- Focus Control: Manual

UV FILTER:

- Shortwave bandpass: 254 nm peak with 25 nm FWHM bandwidth typical
 - Others available upon request
- ### UV Image Intensifier Tube:
- 18mm microchannel wafer type with integral power supply
 - Output window: 180-degree inverting fiber optic
 - Spectral range: 190-780 nm (1×10^{-8} W/cm²)
 - Resolution: 36 line-pairs/mm min., >40 line-pairs/mm typical
 - Output Uniformity: Over a diameter of 17mm minimum and at 2850K, the maximum 2.5:1
 - Output Brightness: Minimum shall be 5 cd/m and with a maximum of 7 cd/m brightness
 - Equivalent Background Illumination: Maximum 0.25 μ lx
 - Bright Source Protection: With operating potential applied, the assembly shall not be damaged when subjected to an input illumination of not less than 40 millilumens concentrated on the photocathode within an area no greater than one square millimeter for a time interval of not less than 45 seconds

- Phosphor screen: P-43
- Screen Quality: With no light to the assembly, observe and locate bright spots or discernible field emissions in the screen when viewed with a 10-power magnifier. With 2×10^{-6} foot-candles incident on the photocathode, there shall be no bright spots or discernible field emissions brighter or larger than the background scintillations on the screen when viewed with a 10-power magnifier
- Luminance gain: The assembly shall have a gain at 2, 10 (-51x) with a minimum of 4500 cd/m²/lx min., and a maximum of 6000 cd/m²/lx
- Cathode sensitivity: Over the useful circle of radiation, the cathode sensitivity at 270 nm shall be a minimum of 45 mA/W and a maximum of 60 mA/W. 400 nm, the minimum sensitivity shall be 60mA/W with a maximum sensitivity of 75 mA/W.
- Sensitivity at wavelengths of particular interest:
 - >35 mA/W at 254 nm
 - >40 mA/W at 313 nm
 - >40 mA/W at 365 nm
 - >50 mA/W at 480 nm
- Gain Control: Auto-ranging
- Life:>5000-7000 hours

SCOPE:

- Housing Support: Allows for simple attachment to tripod
- Ocular: AN-PVS 5B military grade ocular
- Power: 2 ea. AA alkaline batteries, 45-hr. life
- "ON" indicator: Red LED
- Weight: 3.68 lbs.
- Dimensions (with handle): 10.5" x 7.5" x 3.5"
- Materials: Aluminum and Delrin

the Basic **KRIMESITE™** SCOPE Kits...



No. KSS1000C Components

KRIMESITE™ SCOPE Direct View Kit

CONSISTS OF THE FOLLOWING COMPONENTS:

- 1-No. KSS1001 **KRIMESITE™** SCOPE with auto-ranging capability, Nikon® 105mm UV lens, customized for 65% increase in field-of-view and 60% increase in magnification, pistol-grip, ocular and rubber eyecup.
- 1-No. KSS7010 254 nm UV filter (50mm active diameter) with 25 nm bandwidth
- 1-No. KSS7013 Luminol Enhancement Filter (50mm active diameter)
- 1-No. KSS9601 Quick-connect camera coupler for attaching your 35mm camera to the scope. Requires camera and lens (not supplied) with standard 52mm filter thread
- 1-No. KSS9696 Laser Pointer, class IIIa, 100-meter range
- 1-No. 789SW Shortwave (254 nm) UV Lamp, dual 4-watt (total 8-watt), battery/AC-operated
- 1-No. 772SW Shortwave (254 nm) UV lamp, 4-watt, battery-operated
- 1-No. 797GV UV-Protective Goggles
- 2-"AA", 1.5V Alkaline batteries for scope
- 2-"AAA" 1.5V Alkaline batteries for use with laser pointer
- 4-"AA" 1.5V Alkaline batteries for No. 772SW UV light
- 4-"C" 1.5V Alkaline batteries for No. 789SW UV light
- 1- **KRIMESITE™** SCOPE User's Manual
- 1-No. KSS1000K Equipment Case
Case Dimensions: 24.5" x 19.5" x 8.875"
Total Weight: 22.7 lbs.



KRIMESITE™ SCOPE Kit with 35mm Camera

CONSISTS OF THE FOLLOWING COMPONENTS:

- 1-No. KSS1001 **KRIMESITE™** SCOPE with auto-ranging capability, Nikon® 105mm UV lens, customized for 65% increase in field-of-view and 60% increase in magnification, pistol-grip, ocular and rubber eyecup.
- 1-No. KSS7010 254 nm UV filter (50mm active diameter) with 25 nm bandwidth
- 1-No. KSS7013 Luminol Enhancement Filter (50mm active diameter)
- 1-No. KSS9601 Quick-connect camera coupler for attaching your 35mm camera to the scope. Requires camera and lens (not supplied) with standard 52mm filter thread
- 1-No. KSS9696 Laser Pointer, class IIIa, 100-meter range
- 1-No. 789SW Shortwave (254 nm) UV Lamp, dual 4-watt (total 8-watt), battery/AC-operated
- 1-No. 772SW Shortwave (254 nm) UV lamp, 4-watt, battery-operated
- 1-No. 797GV UV-Protective Goggles
- 2-"AA", 1.5V Alkaline batteries for scope
- 2-"AAA" 1.5V Alkaline batteries for use with laser pointer
- 4-"AA" 1.5V Alkaline batteries for No. 772SW UV light
- 4-"C" 1.5V Alkaline batteries for No. 789SW UV light
- 1- **KRIMESITE™** SCOPE User's Manual
- Camera Components:
 - 1-Nikon® N70 35mm Camera
 - 1-50 mm AF Nikkor Lens, f1.4 with 52mm filter thread
 - 2-Rolls Kodak® TMAX P3200, 36-exp. film
 - 1-No. KSS1000K Equipment Case
Case Dimensions: 24.5" x 19.5" x 8.875"
Total Weight: 24.4 lbs.

Cat. No. KSS1000 Direct View **KRIMESITE™** SCOPE Kit (Less Camera) Price: \$15,950.00
 Cat. No. KSS1000C ... Direct View **KRIMESITE™** SCOPE Kit w/ 35mm Nikon® Camera Price: \$16,546.00

Regarding the **KRIMESITE™** SCOPE with Video...



No. KSS1001 with
No. KSS2001 Video
Camera attached

With the **KRIMESITE™** Video Camera, you'll be able to view what the **KRIMESITE™** SCOPE sees enlarged on your video monitor, or record it to your NTSC VCR using either of the two video outputs.

The video camera quickly attaches to the Scope by two captive screws. A belt hook on the video power pack allows hands-free operation.

A microphone built into the battery pack allows you to record comments on what you are observing onto your video tape recorder via the audio output.

Focus and aperture controls allow you to optimize your image.

Video **KRIMESITE™** SCOPE

FEATURES:

OPTICS:

- Nikon® 105mm quartz element lens with modification, capable of close-up and crime scene photography without swapping optics
- Field of View: 12 in. (30.5 cm) at 49 in. (125 cm) 65% more field than standard Nikon® 105mm lens
- Magnification: Full frame image of a fingerprint at 3.75 in. (9.5cm) 60% greater magnification than standard Nikon® 105mm lens
- Spectral Range: 225 nm to infrared
- Focus Control: Manual

UV FILTER:

- Shortwave bandpass: 254 nm peak with 25 nm FWHM bandwidth typical
- Others available upon request

UV IMAGE INTENSIFIER TUBE:

- 18mm microchannel wafer type with integral power supply
- Output window: 180-degree inverting fiber optic
- Spectral range: 190-780 nm (1×10^{-8} W/cm²)
- Resolution: 36 line-pairs/mm min., >40 line-pairs/mm typical
- Output Uniformity: Over a diameter of 17mm minimum and at 2850K, the maximum 2.5:1

- Output Brightness: Minimum shall be 5 cd/m and with a maximum of 7 cd/m brightness
- Equivalent Background Illumination: Maximum 0.25 μ lx
- Bright Source Protection: With operating potential applied, the assembly shall not be damaged when subjected to an input illumination of not less than 40 millilumens concentrated on the photocathode within an area no greater than one square millimeter for a time interval of not less than 45 seconds
- Phosphor screen: P-43
- Screen Quality: With no light to the assembly, observe and locate bright spots or discernible field emissions in the screen when viewed with a 10-power magnifier. With 2×10^{-6} foot-candles incident on the photocathode, there shall be no bright spots or discernible field emissions brighter or larger than the background scintillations on the screen when viewed with a 10-power magnifier
- Luminance gain: The assembly shall have a gain at 2, 10 (-51x) with a minimum of 4500 cd/m²/lx min., and a maximum of 6000 cd/m²/lx
- Cathode sensitivity: Over the useful circle of radiation, the cathode sensitivity at 270 nm shall be a minimum of 45 mA/W and a maximum of 60 mA/W.

400 nm, the minimum sensitivity shall be 60mA/W with a maximum sensitivity of 75 mA/W.

- Sensitivity at wavelengths of particular interest:
 - >35 mA/W at 254 nm
 - >40 mA/W at 313 nm
 - >40 mA/W at 365 nm
 - >50 mA/W at 480 nm

- Gain Control: Auto-ranging
- Life:>5000-7000 hours

SCOPE:

- Housing Support: Allows for simple attachment to tripod

- Ocular: AN-PVS 5B military grade ocular
- Power: 2 ea. AA alkaline batteries, 45-hr. life
- "ON" indicator: Red LED

VIDEO CAMERA:

- 1/3" CCD B&W Image Sensor
- Resolution: 380 lines (H) x 350 lines (V)
- Minimum Illumination: 0.3 lux (faceplate sensitivity)
- Lens: 9mm f1.4
- Auto linear shutter: 1/60 - 1/80,000 sec.
- Linear electronic iris
- Weight: 5.3 lbs. including video power belt pack
- Dimensions: 15' x 7.5" x 3.5" (with handle)



No. KSS2001 Power Pack
and Video Camera

the **KRIMESITE™** SCOPE Video Power Pack

The Video Power Pack provides 12-volt DC power to the KSS2001 and KSS4001 video cameras, and routes their video signals to your companion video monitors, recorders, computers or frame grabbers. A built-in electret microphone allows you to record audio to your video recorder so that you may document images as they are recorded.

Weight: Camera: 0.96 lbs.
Dimensions: Camera: 5.75" x 2.5" Dia.
Materials: Camera housing: Aluminum and Delrin

Belt Pack: (without 8 "AA" batteries): 0.66 lbs.
Belt Pack: 8.75" x 3.5" x 3"
Belt Pack: High-impact plastic

the **KRIMESITE™** SCOPE Video Kit



No. KSS2000 components



No. KSS2000 Kit with components

KRIMESITE™ SCOPE Video Kit

CONSISTS OF THE FOLLOWING COMPONENTS:

- 1-No. KSS1001 **KRIMESITE™** SCOPE with auto-ranging capability, Nikon® 105mm UV lens, customized for 65% increase in field-of-view and 60% increase in magnification, pistol-grip, ocular and rubber eyecup.
- 1-No. KSS7010 254 nm UV filter (50mm active diameter) with 25 nm bandwidth
- 1-No. KSS7013 Luminol Enhancement Filter (50mm active diameter)
- 1-No. KSS9601 Quick-connect camera coupler for attaching your 35mm camera to the scope. Requires camera and lens (not supplied) with standard 52mm filter thread
- 1-No. KSS9696 Laser Pointer, class IIIa, 100-meter range
- 1-No. 789SW Shortwave (254 nm) UV Lamp, dual 4-watt (total 8-watt), battery/AC-operated
- 1-No. 772SW Shortwave (254 nm) UV lamp, 4-watt, battery-operated
- 1-No. 797GV UV-Protective Spectacles
- 2-"AA", 1.5V Alkaline batteries for scope
- 2-"AAA" 1.5V Alkaline batteries for use with laser pointer
- 4-"AA" 1.5V Alkaline batteries for No. 772SW UV light
- 4-"C" 1.5V Alkaline batteries for No. 789SW UV light
- Video Camera Components:**
- 1-No. KSS2001 Quick-connect CCD camera and lens with manual brightness and focus controls
- 1-Video Power Pack with belt clip and connecting cables
- 8-"AA" 1.5V Alkaline batteries for video power pack
- 1-No. KSS2010 Sony® Glasstron video goggles with battery, charger and cables with three display modes
- 1- **KRIMESITE™** SCOPE User's Manual
- 1-No. KSS1000K Equipment Case
Case Dimensions: 19.5" x 24.5" x 8.875"
Total Weight: 25.9 lbs.

Cat. No. KSS2000 **KRIMESITE™** Scope Video Kit Price: \$18,950.00

Video **KRIMESITE™** SCOPE with Evidential Chronicle Color Camera

The Need for the Evidential Chronicle Camera...



The Evidential Chronicle Camera requires no focusing, and adjusts easily to most lighting conditions. Check its output on your video monitor, video recorder or video goggles. It sees and transmits visible light—not reflected UV. Use the **KRIMESITE™** Scope Video Camera to record reflected UV.

Documenting the crime scene as it appears during the recovery of evidence provides the court with a powerful reconstruction.

Show the crime scene as it appeared to your naked eye, then switch to the RUVIS mode to show the same area as the **KRIMESITE™** SCOPE sees it.

This allows you to document the discovery and recovery of fingerprints and other evidence.

It also allows you to revisit the scene to test hypotheses and reconcile evidence from other sources as they are developed over time.

NO. KSS4001 CAMERA SPECIFICATIONS:

- 1/4" DSP color CCD image sensor
- 512 (H) x 492 (V) pixels
- Resolution: 330 TV lines
- Minimum illumination: 3 lux @ f1.4
- Lens: 6mm Micro lens
- Shutter speed: 1/60 - 1/10,000 sec.
- Linear electronic iris
- Weight: 0.34 lbs.
- Dimensions: 4" x 4.25" x 2"
- Materials: Delrin



A. No. KSS4001 Evidential Chronicle Camera



B. **KRIMESITE™** SCOPE UV filter "open" position



C. **KRIMESITE™** SCOPE UV filter "closed" position



D. KSS2001 Video Camera Rear Controls

Video can be recorded through the Chronicle Camera to display the "big picture", through the **KRIMESITE™** SCOPE without the filter or UV light to show the target area as it appears to the naked eye, and with the filter and UV light to show the developed evidence. The Chronicle Camera is selected via the RUVIS/CHRONICLE switch on the back of the video camera.



1. Evidential Chronicle Camera "big picture" scene



2. **KRIMESITE™** Video of target with UV light and filter active



3. **KRIMESITE™** Video close-up with UV light and filter active

KRIMESITE™ SCOPE Kit with Evidential Chronicle Camera



No. KSS2000C components



No. KSS2000C Kit
with components

KRIMESITE™ SCOPE Kit

CONSISTS OF THE FOLLOWING COMPONENTS:

- 1-No. KSS1001 **KRIMESITE™** SCOPE with auto-ranging capability, Nikon® 105mm UV lens, customized for 65% increase in field-of-view and 60% increase in magnification, pistol-grip, ocular and rubber eyecup.
- 1-No. KSS7010 254 nm UV filter (50mm active diameter) with 25 nm bandwidth
- 1-No. KSS7013 Luminol Enhancement Filter (50mm active diameter)
- 1-No. KSS9601 Quick-connect camera coupler for attaching your 35mm camera to the scope. Requires camera and lens (not supplied) with standard 52mm filter thread
- 1-No. KSS9696 Laser Pointer, class IIIa, 100-meter range
- 1-No. 789SW Shortwave (254 nm) UV Lamp, dual 4-watt (total 8-watt), battery/AC-operated
- 1-No. 772SW Shortwave (254 nm) UV lamp, 4-watt, battery-operated
- 1-No. 797GV UV-Protective Spectacles
- 2-"AA", 1.5V Alkaline batteries for scope
- 2-"AAA" 1.5V Alkaline batteries for use with laser pointer
- 4-"AA" 1.5V Alkaline batteries for No. 772SW UV light
- 4-"C" 1.5V Alkaline batteries for No. 789SW UV light

VIDEO CAMERA COMPONENTS:

- 1-No. KSS2001 Quick-connect CCD camera and lens with manual brightness and focus controls
- 1-Video Power Pack with belt clip and connecting cables
- 8-"AA" 1.5V Alkaline batteries for video power pack
- 1-No. KSS2010 Sony® Glasstron video goggles with battery, charger and cables with three display modes

CHRONICLE CAMERA COMPONENTS:

- 1-No. KSS4001 Color camera
- 1-Camera Attachment bracket
- 1-**KRIMESITE™** SCOPE User's Manual
- 1-No. KSS1000K Equipment Case
- Case Dimensions: 19.5" x 24.5" x 8.875"
- Total Weight: 26.2 lbs.

Cat. No. KSS2000C **KRIMESITE™ SCOPE Kit with Chronicle Camera** Price: \$19,925.00

Ultraviolet Light Sources for Reflective Ultraviolet Imaging...

SEARCH® Puissant Ultraviolet Light for large area illumination

As its name implies, this UV source provides enough illumination so that you can set it up in a central location and walk around the area searching with the Scope alone. An audible alarm reminds you that significant shortwave radiation is present. UV-protective measures must be employed.

The **SEARCH®** Puissant Ultraviolet Light is AC only, 30-watt filtered short-wave (254 nm) UV lamp.

LEADING PARTICULARS

- Power Cord: 10 ft. heavy-duty
- Power Source: 110-120 VAC only
- Special Features: Audible and visible "on" indicators
- Output: Filtered output from two (2) 15-watt germicidal bulbs, 254 nm peak emission
- Power Switch: Push-On, Push-Off
- Construction: Vinyl-clad aluminum/brushed nickeloid steel
- Dimensions: 21" x 8.5' x 6"
- Weight: 10.5 lbs

Cat. No. SKSUV30 110/120VAC Price: \$996.50
 Cat. No. SKSUV30220 220VAC Price: \$1,116.50



KRIMESITE™ SCOPE Video Goggles

Lightweight, compact, foldable and made of a durable magnesium alloy, this audio/video headset reproduces the feel of viewing a 52-inch television from approximately 6-1/2 feet away. An adjustable shutter allows you to view the video image from your **KRIMESITE™** SCOPE in variable degrees of transparency floated over the real world (allows you to see where you're walking!) requires the KSS2001 Video Camera attachment.

VIDEO GOGGLES:

Wearing this device allows you to see what the RUVIS sees. In see-through mode you can view the room as well.

Resolution: Equivalent to viewing a 52-inch monitor at 6.6 ft.

Modes:

1. See-Through Mode: Continuously adjustable screen transparency setting allows viewing external environment with screen superimposed to any degree of transparency.
2. Screen Mode: View the external environment through the area surrounding the screen to any degree of transparency while the screen remains opaque to the environment.
3. Mute Mode: View the external environment with the screen fully transparent.

SPECIFICATIONS:

- Weight: Goggles with CCD assembly: 0.8 lbs. (370 g)
- Power: Supplied with Sony® NP-F550 battery, 4.0 hr. life, and 115VAC/9VDC transformer for AC operation
- Power control: .25 lbs (125 g)
- External monitor: Simultaneous viewing on user-supplied monitor
- Video sensitivity: Adjustable independently of intensifier sensitivity
- Cabling: Custom cables to junction box, with standard outputs for connection to user-supplied peripherals such as monitors, computers, video recorders and video printers.



Cat. No. KSS2010 Video Goggles Price: \$699.95



KRIMESITE™ SCOPE Ultraviolet Filters (50mm Active Diameter)

Cat. No.	Filter	CW/L (nm)	FWHM (nm)	Price
KSS7010	254 indoor	253.7 ± 3	25 ± 5	on request
KSS7014	254 outdoor	253.7 ± 5	40 ± 5	on request
KSS7011	313 midwave	313 ± 3	25 ± 5	on request
KSS7012	365 longwave	365 ± 3	25 ± 5	on request
KSS7013	450 luminol	455 ± 5	40 ± 5	on request

Surface Quality 80/50; F/F per MIL-F-48616
 Coating Quality 80/50; F/F per MIL-F-48616
 Operating Temperature Limits: -50°C to + 80°C



1. Immaculate sink and vanity—NO visible blood stains.



2. Close-up of faucet—NO visible blood stains.



Blood Stain Visualization and Photography with the **KRIMESITE™ SCOPE**

Luminol reagent is the preferred choice for locating aged or invisible blood stains. It is the most sensitive presumptive field test for blood (1:5,000,000) but the luminescence exhibited by application of the reagent is retained for only a short time.

Utilization of the **KRIMESITE™ SCOPE** eliminates this disadvantage by amplifying the luminescence not even visible to the unaided eye and evidential photography can be performed without difficulty.

A darkened area and the **KRIMESITE™ SCOPE** Luminol Enhancement filter are required.



Film: KODAK Elite Chrome, 35mm COLOR SLIDE FILM, ISO100
Exposure: f8 @ 1/60 sec.

3. LUMINOL16 Reagent sprayed on sink and faucet. Viewed and photographed with the **KRIMESITE™ SCOPE**.

ULTRAVIOLET EYE and FACE PROTECTION



Spectacles

Top and side shield design provides full UV eye protection.

Cat. No. 797GV \$16.00



Goggles

Lightweight design with rubber trim will accommodate prescription glasses.

Cat. No. 798GV \$18.00



Face Shield

Full face protection from UV light.

Cat. No. 799GV \$50.00

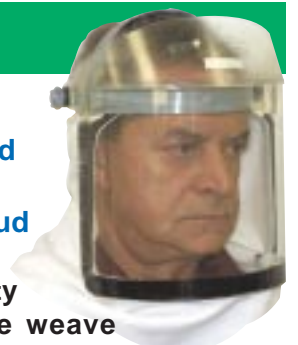

Face Shield with Shroud

High-quality dense weave cotton with Velcro® attachment to face shield. Use with No. SKSUV30.

Cat. No. 798GVH \$79.00

KRIMESITE™ SCOPE Companions and Peripherals

KRIMESITE™ SCOPE Digital Video Recorder

Record digital-quality images of everything the **KRIMESITE™** Scope Video Camera sees, and extract the stills you want later. This high-quality unit uses mini DV cassettes, each recording about one hour of video. Up to 500 lines of horizontal resolution, 3X analog bandwidth, and significantly improved S/N ratio provides stunning video performance and crystal-clear stills.

This device allows you to see and record what the RUVIS sees—and in combination with a digital video printer—to view, print and capture high-resolution images directly from tape. The microphone built into the Video Power Pack allows sound to be recorded with the video.



SPECIFICATIONS:

- Two rotary head, helical scanning video system
- Rotary head PCM audio recording system
- NTSC color, EIA standards
- LCD screen size: 5.5 inches diagonal
- TN LCD/TFT active matrix
- 940 x 234 dot display
- S-video: 4-pin mini-DIN
- Luminance signal: 1 V p-p, 75 ohm, unbalanced, sync negative
- Chrominance signal: 0.286 V p-p, 75 ohm, unbalanced
- Video I/O Phono jack, signal: 1 V p-p, 75 ohm, unbalanced, sync negative
- Audio I/O: 327 mV
- 7.2 V (battery pack), 8.4V (AC adapter/charger)
- Size: 5 7/8" x 2 1/2" x 5 3/8"
- Weight: 2 lb. 2 oz.
- Battery not included
- Digital tape not included

- Cat. No. KSS2020 Digital Recorder Price: \$2,199.00
 Cat. No. KSS2021 Digital Tape, 60-min. Price: \$24.95
 Cat. No. KSS2022 7.2V Rechargeable Lithium Ion Battery Price: \$99.95

KRIMESITE™ SCOPE Digital Printer

The ideal video camera, recorder or PC companion. Capture and print directly from the **KRIMESITE™** Scope Video Camera or the **KRIMESITE™** Digital Recorder at the crime scene.

Provides photo-quality prints directly from your video devices. Also works with your digital cameras. Interfaces directly to your PC or MAC The printer utilizes variable heat intensity to produce pixels that create a full color spectrum and continuous tones, making it ideal for printing photographic images provided by the **KRIMESITE™** Scope Video Camera or Recorder. Printer is 110/120 VAC.



- Cat. No. KSS2015 Digital Printer Price: \$599.50
 Cat. No. KSS2016 Color Ink/Paper Set* Price: \$39.95
 *includes Color Print Paper (50 5 3/4" x 4" sheets) and Ink Cassette for 50 prints

KRIMESITE™ SCOPE Digital Recorder (3.5" Floppy Media)

Allows you to take any standard NTSC video signal from KSS2001, KSS4001, camcorder, VCR, TV, or DVD player and store images onto a standard floppy disk. Because the images are stored on a standard floppy, you can use them in virtually any PC to create documents, send as part of an email or import into image software.



SPECIFICATIONS:

- 2.5", 84k TFT solar color LCD screen
- Quick-access floppy drive (cuts the record and read time in half)
- Four record modes: Normal, non-compressed, email and multi-screen mode
- 640 x 480 pixel, 24-bit color (VGA)
- Storage Media: 3.5" 2HD floppy
- Format: JPEG
- Time Stamp: Date/Time
- Disk Remaining Indicator
- Battery Remaining Indicator
- Analog In/Out: NTSC
- Camera Terminal
- AC power adapter supplied
- Video and S-Video output
- Remote control
- Weight: 1.3 lbs
- Dimensions: 5.1" x 2" x 6.5"
- Battery not included

- Cat. No. KSS2050 Digital Recorder Price: \$499.00
 Cat. No. KSS2022 7.2V Rechargeable Lithium Ion Battery Price: \$99.95

FX7 AND FX7C FORENSIC MACRO VIDEO SYSTEMS

about THE SYSTEMS ...

The **SIRCHIE**® No. FX7 (black & white) and No. FX7C (color) Forensic Macro Video Systems utilize a high-resolution video camera and parfocal zoom lens system to display physical evidence on a video monitor. Magnification of the object being examined is continually variable and the resulting image may be downloaded to a video recorder and/or to a computer equipped with a video capture board. The video capture feature permits a digital image such as a latent fingerprint, tool mark, etc. to be e-mailed or sent via the internet to other agencies.

Special Features:

The camera is equipped with an automatic gain control to ensure optimum images under varying light conditions. The No. FX7 and No. FX7C can be operated under normal room lighting in most circumstances.

The operator makes only two adjustments: focus and zoom. There are no complicated controls requiring constant manipulation. Once an object is brought into sharp focus, and depending on the height of the object, the easy-to-use zoom control may be moved from wide angle ~5 power to telephoto ~59 power without the need to refocus. Flat and three-dimensional objects may be examined.

Dual 13-watt fluorescent lamps provide bright, cool, shadow-free illumination and feature up to 10,000 hours of service and lamp replacement is easy and inexpensive.

If classification of fingerprints is necessary, optional classification discs are available to facilitate this process.

The No. FX7 Forensic Macro Video System



Specifications:

No. FX7C Color Camera

Type: Color interline transfer CCD, 771 x 492 pixels

Light Sensitivity: 3 lux

Resolution: 470 Horizontal lines

TV System: NTSC

Image Format: 1/3" x 4.8mm x 3.6mm

Working Distance: 127mm to 500mm

(Distance between object and first lens element)

Lens: FX7 and FX7C

Zoom Ratio: ~8x

Magnification: ~5x to ~59x

Aperture: f7 wide angle to f10 telephoto

Lens Construction: 10 elements in 7 groups

Effective Diameter: Front: Ø25mm,

Rear: Ø15mm

Back Focus: 19mm at working distance of 235mm

Flange Back: 12.5mm CS-mount

Dimensions: 149.5mm x 46mm

Filter Size: M40.5 x PO.5

No. FX7 Black & White Camera

Type: B&W interline transfer CCD, 512 x 492 pixels

Light Sensitivity: 0.3 lux

Resolution: 550 horizontal lines

TV System: NTSC

Image Format: 1/3" x 4.8mm x 3.6mm

Working Distance: 127mm to 500mm

(Distance between object and first lens element)

Construction

Lamp/Camera Housing: Delrin/Aluminum alloy

Base & Support Arm: Aluminum alloy

Power Requirements: 120VAC, 60 Hz

Dimensions: 15.5"H x 12" W x 13" D

Weight: 21 lbs.



Weapon serial number



Latent fingerprint



No. FX7C shown with optional 13" monitor

The No. FX7 and FX7C will operate with any NTSC monitor and some TV sets.

Accessories:

Catalog No.	Description	Price
PTVM100	13" Color Monitor	\$395.00
JC401H	Henry Classification Disc	\$56.95
JC401B	Battley Classification Disc	\$58.95
JC401HB	Henry/Battley Classification Disc	\$57.95
JC401C	Miracode Classification Disc	\$61.95

CATALOG NO. FX7 BLACK/WHITE FORENSIC MACRO SYSTEM PRICE: \$1,395.00
CATALOG NO. FX7C COLOR FORENSIC MACRO SYSTEM PRICE: \$1,595.00

FX4 FORENSIC MACRO VIDEO SYSTEM

about THE SYSTEM ...

SIRCHIE® engineers have created the ultimate laboratory aid. The No. FX4 with its extended viewing range—2.375x to 48x magnification*—small and large objects are easily examined. Ruggedly constructed from the finest materials available, the No. FX4 Forensic Macro Video System outclasses any device in its field.

Operation is straightforward with all controls within comfortable reach. Once switched on, the only adjustments needed are raising or lowering the motor-driven camera head, then focus the lens and zoom to the desired magnification.

Imagine being able to view a latent print from full size to the point where ridges measure almost a half-inch wide on the TV monitor. In ridgeology studies, it becomes possible to actually count the pores along a ridge and measure the distance between them. Eyestrain will be a thing of the past.

The black and white TV camera is state-of-the-art with a 0.3-lux rating and the built-in fluorescent lighting provides diffuse, bright, easy-on-the-eyes illumination. In addition to the forensic lighting, the No. FX4 features a high-intensity fiber-optic lighting system. This is especially useful when working under full magnification and the adjustable fiber optic tubes permit manipulating the light beam to create shadow detail on three-dimensional objects. Details of toolmarks, plaster and silicone casts jump right off the surface permitting quick and positive identification. The system works well in brightly lighted laboratory conditions.

Simply put, the No. FX4 is a marvel of engineering and may virtually eliminate the need for many types of crime laboratory microscopes—and their inherent difficulties—that are used for forensic examination of physical evidence.



FX4 RESULTANT EXEMPLARS



*Criminal record card
min. magnification,
minimum zoom*



*Left index finger from
above card*

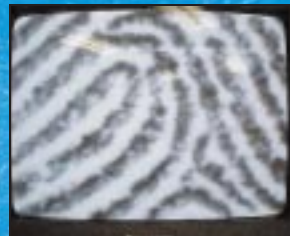

*Maximum magnification,
maximum zoom of index
finger*

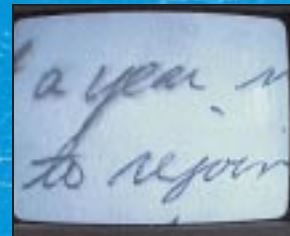

Document Examination



*Latent print on soft
drink can*

Specifications:

No. FX4 Black and White Camera

Type: Black and white interline transfer CCD,
512 x 492 pixels

Light Sensitivity: 0.3 lux

Resolution: 550 Horizontal lines

TV System: NTSC

Image Format: 1/3" x 4.8mm x 3.6mm

Working Distance: 17 inches
(Distance between object and first lens element)

Lens:

Zoom Ratio: ~8x

Magnification*: 2.375x to 48

Aperture: f7 wide angle to f10 telephoto

Lens Construction: 10 elements in 7 groups

Effective Diameter: Front: Ø25mm,

Rear: Ø15mm

Back Focus: 19mm at working distance of 235mm

Flange Back: 12.5mm CS-mount

Dimensions: 149.5mm x 46mm

Filter Size: M40.5 x PO.5

Construction:

Gear Motor: Permanent-magnet DC servo

Motor Specifications:

12VDC 120 RPM max.

Torque: 36 in.-oz.

Gear Ratio: 19.66:1

Full Load Amperage: 1.50 amps

Shaft Size: 0.249"

Rail & Bearing System:

Bearing Material: chrome & stainless steel

Support Rail Material: Stainless steel

Lead Screw: 1/2-10 thread, stainless steel

Travel: 12.50 vertical w/rule

DC Linear Power Supply:

Output: 12VDC @3.4 amps

Input: 120VAC, 60 Hz

Ripple: 3.0 mV Max. P-P

Auto current limiting

Operating Temperature: 0°C to 50°C

Accessory Connectors:

AC Output: Switched 3-prong, grounded out-

lets (4 on rear panel)

AC Input: 3-prong, grounded, flush mount

Video Out: RCA Jack

Power Switches: SPST Corvette Visi-Red rockers with on/off imprint

Switch Functions: Control for camera, built-in light source, and motor drive, switched

Motor Control Switch: 4PDT Panel-mounted momentary Rocker

Power Cord: 18 AWG, 6' long, 3-prong grounded

Fuse: Rear panel mounted

Materials: Aluminum-alloy housing and base, gray powder-painted finish

Dimensions: 27.5" H x 17.5"W x 24" D

Weight: 68lbs.

**Magnification is based upon measurements taken from the PTVM100 13" monitor. Greater magnification is possible with larger screen sizes.*

The FX4 Forensic Macro Video System shown with optional PTVM100 video monitor



No. FX4 fiber-optic lighting in use



Latent blood print on paper

The No. FX4 system includes:

- stand
- motor drive
- housing containing b&w camera and lighting
- fiber-optic illuminator
- power cable
- complete instructions

Monitor and digital recorder purchased separately.

Specifications:

No. FX4 Fiber Optics Illuminator
 Output: 250 watt/115 VAC single port
 Output Intensity: 50% to 100% adjustable
 Cooling Fan: Internal, high volume
 Power Switch: ON/OFF rocker
 Material: Aluminum-alloy housing, powder-painted finish
 Dimensions: 9" L x 4.62" H x 6" D
 Weight: 7 lbs.

CATALOG NO. FX4 FORENSIC MACRO VIDEO SYSTEM PRICE: \$5,995.00

FX4 RESULTANT EXEMPLARS



Examination of U.S. currency



Serial number obliteration



Close-up of burglar tool



Indented writing



Mikrosil cast of shoe print

DIGITAL VIDEO PRINTER

Since the KSS3050 Digital Video Color Printer offers resolution of 1.4 million pixels, it is capable of producing near photo-quality prints in under 2 minutes. You may print images captured from the No. FX4 or any NTSC video sources such as video cameras or VCRs. A built-in floppy drive permits recording your images for transfer to a PC.

(Includes printer, cables and instructions)



CATALOG NO. KSS3050 PRICE: \$499.00

VIDEO MONITOR

This all-purpose video monitor is the perfect tool for crime laboratories needing a flexible, dependable means of viewing forensic evidence. The No. PTVM100 provides multiple inputs for composite video and audio as well as an S-VHS input. Video and audio output jacks permit feeding auxiliary devices such as VCRs, disk recorders or computer inputs.

Specifications:

Power Source: 120 VAC, 60 Hz
 Video Inputs: (3) 1 v p-p, BNC connectors
 Audio Inputs: (3) 500mV rms, RCA connectors
 S-Video Input: S-VHS (Y-C) connector
 Video & Audio Monitor Output: RCA connector
 Video & Audio Throughout Jacks: RCA connectors
 S-Video Throughout Jack: S-VHS (Y-C) connector
 Earphone Jack: (front panel) 1/8" mini-plug
 Closed caption display
 Dimensions: 13.25" H x 14" W x 14.5" D
 Weight: 20.3 lbs.



CATALOG NO. PTVM100 PRICE: \$395.00

FORENSIC FLUORESCENCE LIGHT KIT



about THE KIT ...

The FF100 Forensic Fluorescence Light Kit is a lightweight, modular illumination system consisting of a high intensity light source and interchangeable filter assemblies. The lamp module is built around a 12-volt, 100-watt quartz-halogen lamp that boasts an average life of 1500 hours. The easily-interchanged filter modules alter the high-intensity light to provide an excitation source at wavelengths necessary to cause fluorescence for forensic examination of evidence and barrier filters to allow the fluorescence to be isolated. The FF100 is the only alternative light system currently available offering full photographic capability at a cost far less than other systems.

Theory of Operation

Items of forensic interest such as physiological fluids, certain drugs, arson accelerants and chemically treated latent fingerprints exhibit a phenomenon known as fluorescence. Exposing these items with light of particular wavelengths—known as excitation—will cause them to emit a different color light.

This shift in color, the Stokes Shift can be separated out from the excitation wavelengths through the use of barrier filters. This fluorescence may then be photographed, videotaped or collected for further analysis.

By employing several different filter combinations, the FF100 covers the spectrum from 410 nm to 600 nm.

Field and Lab Use

The basic FF100 kit is designed primarily for laboratory use but when the optional battery pack is employed, the kit serves as a fully portable aid at the crime scene.

- Crime scene or laboratory operation
- Safe to use without protective goggles
- Portable compact design
- Does not interfere with subsequent forensic tests
- Can be attached to 35mm or video camera
- Operates under day or night lighting conditions



DFO-stained print viewed with No. FF1002 filter



No. FF1006 DC Power Supply



Four filter assemblies supplied with the No. FF100 Kit and No. FF200 Kit

The FF100 Forensic Fluorescence Light Kit fills a niche in evidence identification and recovery. While numerous alternative light sources exist today, this unique system provides advantages not found in other methods or equipment. While the argon laser has proven to be effective in some applications, it is limited in its spectrum of coverage, requires the use of protective goggles, darkness and is very costly. Other alternative incandescent systems are only similar in application, do not offer simple-to-use photo and video recovery and are considerably costlier requiring darkness for examination.



No. FF1000 Excitation Lamp Head with No. FF1001 Filter Assembly



BARRIER MODULES

Specifications:

Excitation/Viewing Head

Principle Use: Viewing evidence likely to exhibit fluorescent qualities

Image Recording: 35mm camera equipped w/macro adapter mounts directly to viewer (52mm adapter supplied. Specify other sizes when ordering.)

Material: All aluminum alloy housing, gray powder painted finish

Dimensions: 3.50" W x 3.88" L x 3.12" H

Weight: 14.1 oz.

Four standard filter systems are supplied with the FF100 kit:

Module No.	Excitation Band	Edge	Principal Use
FF1001	410-490 nm	10 nm	Basic Yellow/Ardrox-stained prints
FF1002	460-540 nm	550 nm	DFO, Semen, Urine
FF1003	520-590 nm	600 nm	DFO, Fluorescent Powders
FF1004	400-475 nm	475 nm	Near-UV-Sensitive Print Powders



No. FF1001 Filter
Ardrox-stained latent print



No. FF1002 Filter
DFO-stained print



No. FF1003 Filter
No. LL603 powder (see page 57)



No. FF1004 Filter
No. LL602 powder (see page 57)

Recording Physical Evidence using 35mm Film

Recording physical evidence such as latent prints, physiological fluids and various chemical stains becomes a routine exercise when using the FF100 system. Equipment required includes a 35mm camera body (customer-supplied) with built-in light metering, a normal (50mm) lens with a 52mm filter thread (other sizes available), the 52mm macro adapter supplied with the system and color negative or slide film.

With the proper filter assembly in place, the technician locates any potential evidence through the eyepiece viewer. The eyepiece is then removed and the macro attachment is screwed into its place. After attaching the camera to the macro adapter, the technician centers the object in the camera viewfinder, focuses the lens, chooses the proper exposure and snaps the shutter.



VIDEO ATTACHMENT



SIRCHIE® has developed a high-resolution video recording system that quickly attaches to the filter assembly. Using the macro attachment supplied with the system, attach the camera to the proper filter assembly, focus and begin recording. Results may be recorded on videotape, displayed on a video monitor or downloaded into a computer

equipped with a video capture board. Results may then be transmitted via e-mail or the internet to other agencies. A hardcopy is made using the optional video printer (see page 318).

CATALOG NO. FF120..... PRICE: \$994.95

FORENSIC FLUORESCENCE LIGHT KIT



No. FF100 Kit consists of:

- 1-FF1000 Lamp housing
- 1-FF1001 Excitation/viewing head (410 nm to 490 nm)
- 1-FF1002 Excitation/viewing head (460 nm to 540 nm)
- 1-FF1003 Excitation/viewing head (520 nm to 590 nm)
- 1-FF1004 Excitation/viewing head (400 nm to 475 nm)
- 4-FF1005 Excitation/viewing head magnifying assembly
- 1-FF1006 Power supply, 110 VAC
- 1-FF1007 DC power cord
- 1-FF1008 Lens hood, 52mm
- 1-FF1009 High-impact, watertight carrying case
Dimensions: 24" L x 19" W x 8.5" D

Specifications:

No. FF1000 Lamp Housing

Lamp Module: 12VDC, 100-watt quartz halogen lamp
Lamp Replacement: Aluminum alloy access cover/lamp holder with ejector handle

Cooling Fan: 12 VDC, 0.23 amp/brushless

Bearing System: Ball bearing
 Airflow: 9.2 CFM
 Average Lifespan: 40,000 hours continuous
 External finger guard

Accessory Connectors: Rear panel mounted

Output power: 4-pin circular
 Video Out: 2-conductor phone jack

Power Switch: SPS Curvette Visi-Red rocker with on/off imprint

Power Cord: 18 AWG 6-ft., 2-conductor
 Cigarette lighter adapter (5 amp fuse w/ red indicator)
 Pigtail strain relief in housing

Material: All aluminum alloy housing, gray powder painted finish

Handle: Phenolic thermoset, black (1.00" W x 4.50" L)

Case Dimensions: 3.50" W x 6.00" L x 5.00" H

Weight: 1 lb., 3.2 oz.

No. FF1005 Excitation Head Magnifier Assembly

Magnifier Lens: 50 mm x 120mm plan-convex
 One assembly provided for each viewing head

Material: All aluminum alloy housing/bright-dipped black anodized

Dimensions: 2.12" Diameter x 0.44 thick

Weight: 1.0 oz.

No. FF1006 Power Supply

Case Material: All steel housing, vented for cooling
Output: 13.8 VDC, 15 amps

Input: 115/230 VAC, 60/50 Hz switchable

Circuit Protection: 4 amp fuse, fully regulated
 Electronic overload protection w/auto reset

Power Cord: 18 AWG, 5 ft., grounded

Dimensions: 10" L x 6" W x 4.5"H

Weight: 12.75 lbs.

Weight: 31 lbs

CATALOG. NO. FF100 PRICE:\$2,496.00

PORTABLE BATTERY PACK

The No. FF1010 portable 12 VDC power pack is designed for use in the most demanding conditions. The power pack is easily transported to the crime scene as a power source for the FF100 kit.

Specifications:

Battery Pack: Extended-life, leak-proof, lead acid rated at 12 VDC @ 17 amp hrs.

Case: Impact-resistant, vacuum-formed polypropylene housing

2 Nylon Web Straps: To secure the enclosure and serve as belt loops for hands-free use.

Recharge Time: 24 hours (may be left on charge for up to 20 days)

The FF1010 includes battery pack, shoulder strap, belt straps and complete instructions.



CATALOG NO.	DESCRIPTION	PRICE
FF1010	BATTERY PACK	\$178.50
FF1011	CHARGER	\$14.96
FF1012	12' EXTENSION CORD	\$16.50
FF1013	REPLACEMENT LAMP	\$39.50

BLUEMAXX™ MODULE

The BLUEMAXX™ module permits the FF100 system to serve as a crime scene search tool. When attached to the FF1000 lamp housing, the technician may perform a preliminary search to locate physical evidence such as latent prints, physiological residue, hair, fibers, etc. Barrier goggles permit the operator to visualize fluorescence.

Specifications:

Excitation Filter: All-dielectric coating, 390 to 520 nm passband

Housing: All aluminum-alloy, gray powder paint finish

Head Material: Cyclocac-T grade ABS, blue

Dimensions: 3.50" W x 3.62" L x 3.12" H

Weight: 13.8 oz.



CATALOG NO.	DESCRIPTION	PRICE
FF1015	FILTER WITH GOGGLES	\$196.75

FF200 FORENSIC FLUORESCENCE VIDEO LIGHT KIT



FVC120 in use with optional Digital Video Capture Recorder. See page 318 for specifications.



BLUEMAXX™ Filter assembly used for crime scene search

Specifications:

No. FVC120 Video Camera

Color Video Camera (PC Board Mounted)

Pick-Up Element: 1/3" DSP Color DDC Image Sensor

Sensor: 768 Horizontal x 494 Vertical Pixels

Scanning System: 2:1 Interface

Sync System: Internal

Scanning Frequency: 15,735 KHz
Resolution: 489 TV lines

S/N Ratio: More than 48 dB

Minimum Illumination: 2 lux

Gamma: 0.45

Video Output: 1 V PP (75 ohms)

Electronic Shutter: Auto w/ Backlight compensation

Power Supply: 12 VDC ± 5%
Power Consumption: 250 mA

Lens Mount: CS Mount

Operating Temperature: -10°C to 45°C

Objective Lens: (8.5 mm, f 1.3, C-mount)

Aperture Range: f1.3 to f16 (closed)

Image Format: 8.8mm x 6.6mm

Effective Focal Length (EFL): 8.50mm

Back Focal Length (BFL): 12.3 mm

Flange Focal Length: 17.526 mm

Horizontal Field of View (FOV): 54.7°

Vertical Field of View (FOV): 42.4°

Diagonal Field of View (FOV): 65.8°

Power Cord: 28 AWG 4-conductor, coiled

Retracted Length: 2 ft.

Extended Length: 10 ft.

4-Pin circular twist-lock connector

External Power Jack: Accessory connection

Power Switch: SPST, recessed toggle

Power Indicator: Red, super-bright LED

Material: All aluminum alloy, bright-dipped, black anodized

Dimensions: 2.50" Wide x 2.50" Deep x 4.25" High

Weight: 13.9 oz.

No. FVC120 Video Camera Adapter Ring

Material: All aluminum alloy, bright-dipped, black anodized

Camera Support: Recess for video camera base. Thumbscrews for securing

Illuminator Connection: 52mm Threads for mounting to FF1000-FF1004

Dimensions: 2.56" Diameter x 0.44" High

Weight: 0.2 oz.

No. FF1014 Macro Coupler

Material: All aluminum alloy, bright-dipped, black anodized

Dimensions: 2.12" Diameter x 0.31" High

Weight: 0.2 oz.

No. FF200 Kit consists of:

- 1-FVC120 Video camera
- 1-FF1200 Video camera adapter ring
- 1-FF1014 Macro coupler
- 1-FF1000 Lamp housing
- 1-FF1006 Power supply
- 1-FF1001 Excitation/viewing head*
- 1-FF1002 Excitation/viewing head*
- 1-FF1003 Excitation/viewing head*
- 1-FF1004 Excitation/viewing head*
- 4-FF1005 Excitation/viewing head magnifying assemblies
- 1-FF1015 BLUEMAXX™ module*
- 1-BMS400 Barrier goggles
- 1-Set interconnecting cables
- 1-FF2009 Heavy-duty carrying case w/ precut insert*
- Dimensions: 32.5" L x 20.5" W x 11" D
- Weight: 45.75 lbs
- 1-Set complete instructions

CATALOG. NO. FF200 FF200 VIDEO LIGHT KIT PRICE: \$3,694.00

FVC100 FORENSIC VIDEO CAMERA

A FULLY PORTABLE FORENSIC EVIDENCE RECORDING CAMERA

about THE CAMERA ...

The No. FVC100 is the answer to the evidence collection technician's prayer. At last, one easy-to-use device can perform most of the tasks related to recording physical evidence at the crime scene and in the lab. This multi-purpose camera offers a focusing range from macro (close-up) to infinity. **But, you ask, why video—when ordinary still cameras have sufficed for years?** The simplest answer we can give is that technology is leaning toward digital recording methods for many photographic missions. The advantages are endless. Here are just a few:

- Digital photography doesn't require the use of film
- This one device may be used to videotape the crime scene as well as record all of the physical evidence present
- A variety of recording media are available. You can record to a VCR, a portable video capture device that records your photos onto a standard floppy disk, or download directly into a PC or notebook computer.
- Using a video camera like the No. FVC100 provides unlimited flexibility and many more choices over conventional film
- You can monitor each shot as it is recorded, assuring that you have indeed used the proper exposure, framing, etc. and record live audio explaining each shot, assuming that you purchase the No. KSS2020 Digital Recorder (see page 318).

Leading Particulars:

- Color video camera, high resolution: 480 TV lines
- Functions well under low light conditions: 2 lux
- External power jack for accessories
- Compact, lightweight design
- Fully portable
- Ideal for field and lab use
- Adjustable f-stops and focus
- Operates with VCRs, digital capture devices
- Electronic shutter
- Focus from macro to infinity
- Microphone jack permits recording while taping

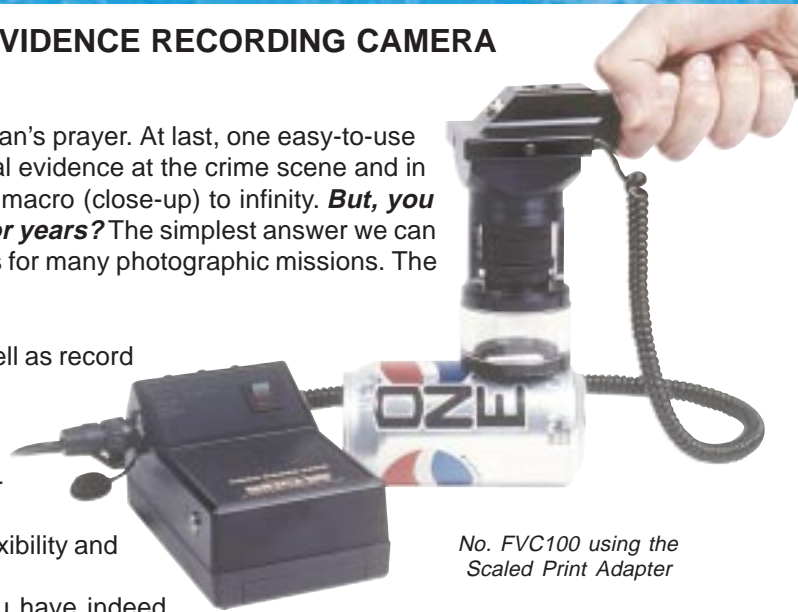

No. FVC100 using the Scaled Print Adapter



Resultant photo*



The No. FVC100 recording the crime scene



Medium closeup of the scene



Victim photo recorded by the No. FVC100

*Note: All resultant photos shown here were captured using the No. FVC100 camera



Shoe print



Shooting scene evidence



Scar on suspect's arm



Establishing shot of blood prints

Specifications:

No. FVC100 Video Camera

Color Video Camera (PC Board Mounted)
Pick-Up Element: 1/3" DSP Color CCD
Resolution: 480 TV lines
S/N Ratio: More than 48 dB
Minimum Illumination: 2 lux
Video Output: 1 V PP (75 Ohms)
Electronic Shutter: Auto w/ backlight compensation
Power Supply: 12 VDC +/-5%

Power Consumption: 250 mA
Lens Mount: CS mount
Operating Temperature: -10°C to 45°C
Objective Lens: 8.5mm, 11.3, C-Mount
Aperture Range: Adjustable from f1.3 to f16 (closed)
Image Format: 8.8 mm x 6.6mm
Horizontal Field of View (FOV): 54.7°
Vertical Field of View (FOV): 42.4°
Diagonal Field of View (FOV): 65.8°

Power Cord: 28 AWG 4-Conductor, coiled, Retracted: 2 ft., Extended: 10 ft.
External Power Jack: Accessory connection
Power Switch: SPST, recessed toggle
Power Indicator: Red, superbright LED
Material: All aluminum-alloy, bright-dipped, black anodized
Handle: Phenolic thermoset-black, 1"W x 4.5"L
Dimensions: 2.5"W x 2.5"D x 4.25"H
Weight: 15.4 oz.



No. FVC1005 stand in footprint mode



No. FVC1001 Video Power Pack
 Housing: Injection-molded plastic, black
 Power Source: 12 VDC output (8 "AA" 1.5 VDC alkaline batteries)
 Power Switch: Illuminated SPST rocker with red LED
 Power Out Connector: 4-Pin circular, panel mount
 Video Out Connector: RCA-type
 Dimensions: 2.88"H x 3.75"W x 5.75"L
 Weight: 16.3 (10.0 without batteries)



No. KSS2050 Digital Recorder

- 2.5" 84k LCD screen
- Quick-access floppy drive
- Four record modes
- 640 x 480 pixels
- Storage Media: 3.5" 2HD floppy
- Format: JPEG
- Date/Time stamp
- Dimensions: 5.1" x 2" x 6.5"
- Weight: 1.3 lbs.

(See page 318)



No. FVC1003 Scaled Latent Print Adapter
 Housing: Clear acrylic tubing, aluminum-alloy, bright-dipped, black anodized
 Latent Print Scale: 0.125" gradient horizontally, 1.0mm gradient vertically
 Latent Viewing Area: 1.156" horizontal x 0.750" vertical
 Dimensions: 2.25" Dia. x 1.38" H
 Weight: 1.6 oz.

No. FVC1004 Latent Print Adapter (not shown)
 Housing: Clear acrylic tubing
 Latent Viewing Area: 1.750" Dia.
 Dimensions: 2.25" Dia. x 1.38" H
 Weight: 1.3 oz.



Weapon recorded by the No. FVC100



Latent fingerprint from the weapon taken by the No. FVC100



Latent palm print from weapon taken by the No. FVC100



No. FVC100 Kit consists of:

- 1-FVC100 Forensic Video Camera
- 1-FVC1001 Video Power Pack
- 1-FVC1003 Scaled Print Adapter
- 1-FVC1004 Latent Print Adapter
- 1-FVC1005 Camera Stand
- 1-FVC1010 Digital Recorder Body Harness

- 1-KSS2050 Digital Recorder
- 1-Weatherproof carrying case
Dimensions: 24" x 19" x 8.5"
- 1-Set, Complete Instructions

CATALOG NO.	DESCRIPTION	PRICE
FVC100	FORENSIC VIDEO CAMERA KIT	\$1,995.00

introducing ALIS™...

...an AUTOMATED LATENT IDENTIFICATION SYSTEM

Finally...

TRUE minutiae-based latent print comparison software for your desktop computer!

Designed as high performance tools to...

aid the latent print examiner, our ALIS™ software systems feature state-of-the-art feature extraction and a 1 to 1 comparison engine with an easy to learn interface.

what's next?



Monitor, scanner, keyboard and mouse not included

Our ALIS™ family of programs are designed to allow comparison of **fingerprints, and/or palmprints** in desktop or portable PC's. In combination with a page/film scanner or video capture device, prints can be easily and rapidly brought into the computer, processed and compared with any other previously stored print or dataset.

Each ALIS™ system utilizes SIRCHIE®'s state-of-the-art image processing and minutiae extraction algorithms to automatically and rapidly locate points of minutia such as ending ridges, islands and bifurcations.

ALIS™ System Leading Particulars:

- Acquire images via any TWAIN-compliant device
- Visually compare prints side-by-side over a large range of magnifications
- Automatically extract features such as ending ridges, islands and bifurcations
- Manually add or delete features and direction of flow.
- Add and remove selective bad areas for custom minutiae processing
- Flip, mirror, invert, adjust brightness, contrast and sharpness for optimum feature extraction
- View or print grayscale, binary, enhanced or skeletonized images of ridge structure
- Automatically compare latent and recorded prints
- Create and define 'area of interest' for selective comparisons
- Numerical and bargraph scale indicators shows latest compare rating
- Two graphical lines overlay modes to pinpoint compared minutiae in both prints
- Export images in JPEG, TIFF, TARGA or BMP formats for archival or use in other programs
- Print latent print, reference print, or the full screen to any Windows-compatible graphics printer
- Print any image that can be displayed on screen for off-line examination
- Save fully processed prints as datasets for rapid reload and comparison with other prints

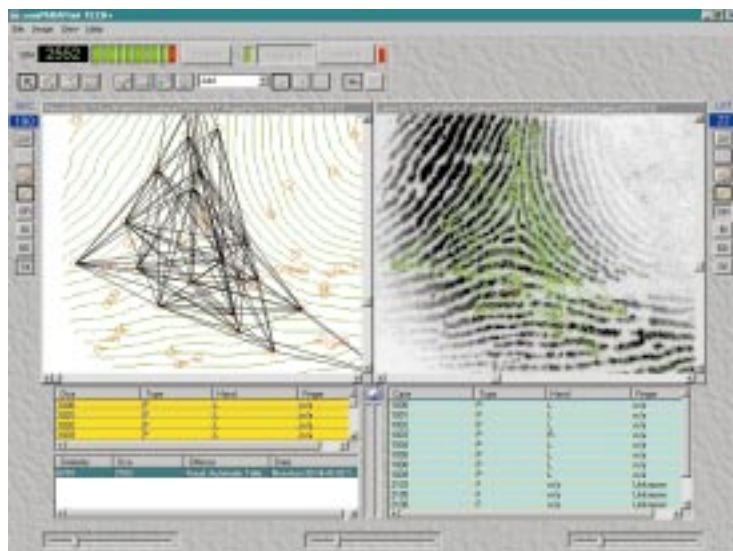

Comparison analysis of a latent fingerprint as a result of a search of latent print to the recorded database in comPARAPrint TECH+Db system software.

introducing ALIS™an AUTOMATED LATENT IDENTIFICATION SYSTEM

ALIS™ IMAGE PROCESSING...

ALIS™ Systems image enhancement algorithms offer the examiner different views of the print to aid in his decision to add or remove points of minutiae. Scanned images are processed and presented as both binary, skeletonized and enhanced images. The binary image results from the application of a sophisticated process which first determines what areas of the print constitute ridges and what constitute background, and then removes the background while enhancing the ridges. The skeletonized, or thinned image, is the result of a process that removes extra pixels and produces a simpler image still made up entirely of pixels belonging to the skeleton of the object.

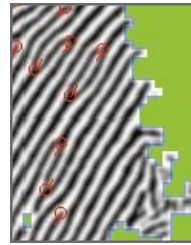

ENHANCED

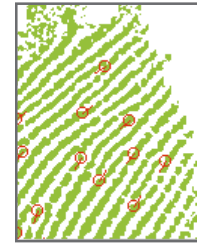

BINARY

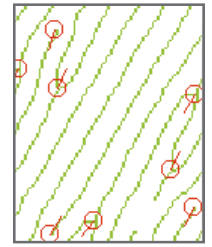

SKELETAL

ALIS™ AUTO FEATURE EXTRACTION...

Our feature extraction engine automatically extracts minutiae and eliminates questionable areas of the prints, including smudges, so that they will not be considered in the comparison.

Points of minutiae are located using sophisticated rules based on the cumulative knowledge of expert examiners. Operators can easily intervene and override when necessary too.

Each print is individually processed which generates data detailing the coordinates of the features located in the print.

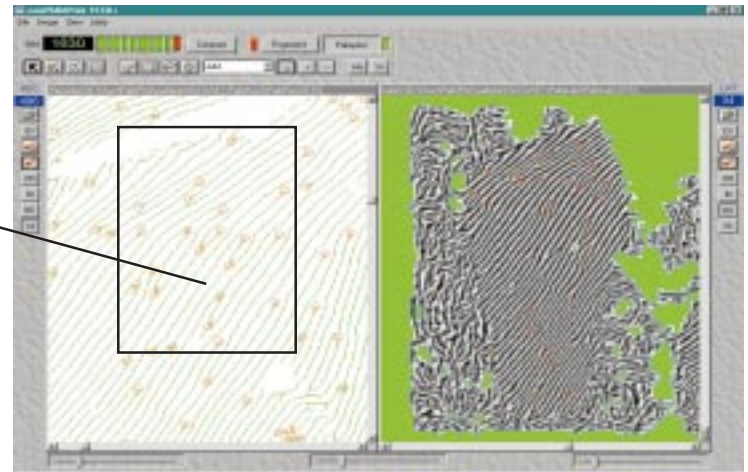
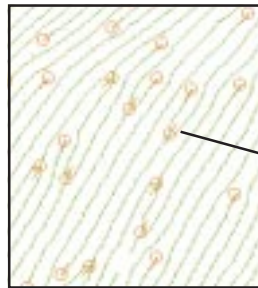

The minutia extraction algorithm determines bad area elimination, ridge direction, minutia points and breaks the image down into skeletal, binary and enhanced images for subsequent viewing options. (Palmprint comparison shown using comPARAPrint TECH+)



Graphical and numerical indicators constantly show the user the current similarity between the two prints being compared

ALIS™ COMPARISON ENGINE...

The ALIS™ comparison engine automatically makes a statistical comparison of the two prints, displaying a goodness rating for the comparison based on minutiae similarity. The higher the rating the more similarity between the prints!

Activate the graphical overlay feature to show just what features in each print the comparison engine used as the basis of its decision, and the technician may intervene where necessary or desired.

Compare the full latent, or on any user-defined portion of the latent utilizing the 'Area of Interest' function.

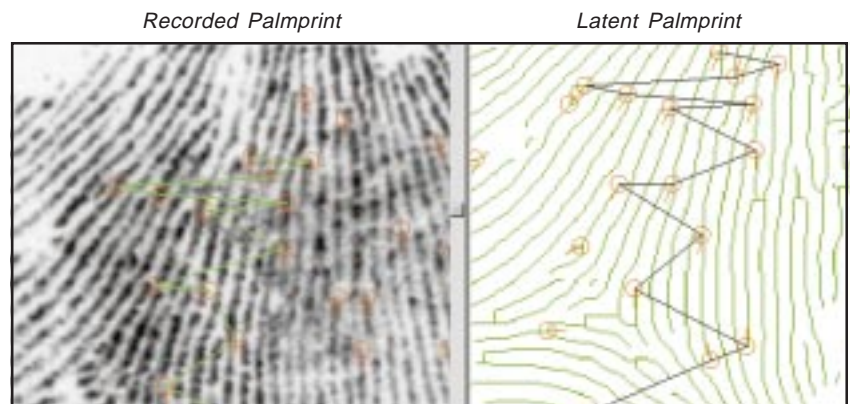

The 'Y-Ascending' lines function simplifies features comparison

introducing **ALIS™**...
 ...an **AUTOMATED LATENT IDENTIFICATION SYSTEM**

ALIS™ PRINTING AND EXPORTING...

Utilize the ALIS™ minutiae plots and intermediate processed images in other software for courtroom presentations, etc. The export function allows you to save processed images, including their points of minutiae, in standard graphics formats such as TIFF, TARGA, JPEG and Windows Bitmap (BMP). Images may be printed on any Windows-compatible graphics printer as scanned, or as enhanced, with or without features included.



With appropriately configured PC's, ALIS software is capable of inputting video captures from the following SIRCHIE® macro video products.

Product	See Page
No. FX4	321
No. FX7	319
No. FX7C	319
No. FX10	141
No. FVC100	327
No. FVC120	323

Recommended Minimum PC Hardware requirements:
Operating System: Windows 95+, or NT 4.0+
Hardware: 333 Mhz Pentium-Class processor or better
Memory: 128Mb Ram
Video: Video card capable of 800 x 600 screen resolution at 16-bit color depth
Graphical Input Device: Page Scanner 600 dpi minimum
Monitor: Color Monitor with 17" to 19" minimum viewing area

CHOOSE AN ALIS™ SYSTEM THAT'S JUST RIGHT FOR YOU...

comPARAFingerprint

Your most demanding task may be comparing latent fingerprints with suspect fingerprints. This system is designed and optimized to process and compare just latent fingerprints to recorded fingerprints—one-to-one. Scan the latent and recorded prints with a TWAIN compliant page scanner, process the prints and edit minutiae right on screen—then compare the prints for results comparison. Save your processed work as a Dataset for later retrieval and much more.

CAT NO. CCPARA5000L ALIS™ FINGERPRINT COMPARATOR SYSTEM PRICE: \$1,995.00

comPARAPalmprint

This ALIS™ system package is designed and optimized for One-on-One palmprint comparisons. With this software you can locate the respondent site in minutes, shortening the time-consuming task of manual comparisons greatly. Palm print comparisons with as little as 5 minutiae points can be realized! Conduct comparisons on the most fragmentary prints devoid of ridge clues and with unknown orientation. You've heard of automated palmprint comparators...Now you can put one on your desktop.

CAT NO. CCPARA6000L ALIS™ PALMPRINT COMPARATOR SYSTEM PRICE: \$3,995.00

comPARAPrint TECH+

Purchase this ALIS™ system and get the combined capability of comPARAFingerprint AND comPARAPalmprint all in one package! Conduct a full complement of comparisons of fingerprints and palmprints with this complete comparison suite. Contains all of the ALIS™ functionality of comPARAFingerprint and comPARAPalmprint.

CAT NO. CCPARA7000L comPARAPrint™ TECH+ PRICE: \$4,995.00

comPARAPrint TECH+Db

This premier ALIS™ system combines all the functionality of our comPARAPrint TECH+ system with the added capability of storing fingerprints and palmprints datasets to an online database. This database system allows separate storage of recorded and latent prints...with a record limit of 500 records per database. Open a latent print from the latent database and quickly search the recorded database for respondents. Run actual searches of latent prints to those prints in the recorded database and view the respondent list by highest similarity. Open any print from the respondent list for quick one-to-one on screen comparisons with the current latent.

CAT NO. CCPARA7000LDB comPARAPrint™ TECH+DB PRICE: \$5,995.00

comPARAPrint II is the latest ...

in the growing family of software applications from **SIRCHIE®** designed to bring computer aided latent fingerprint searching and comparison to the desktop PC. Designed for the small to medium sized law enforcement agencies, this high performance tool serves as a department fingerprint identification system. Built upon our **ALIST™** engine technology and coupled with a robust 10-print card database capable of holding a virtually unlimited number of cards (limited by your storage capacity), **SAFIS™** becomes an powerful tool for optimized comparisons between a latent fingerprint and the prints in the database at the click of a button.

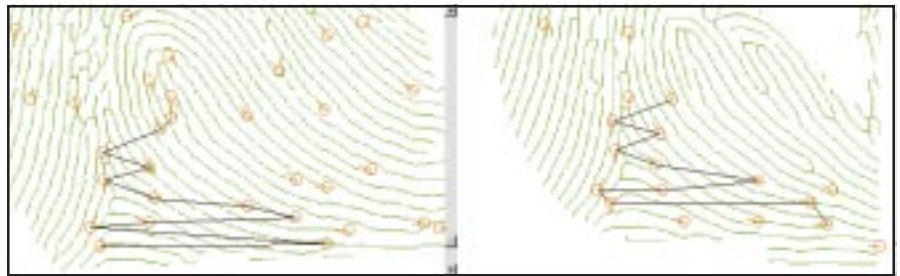

The skeletonized, or thinned image, is the result of a process that removes extra pixels and produces a simpler image still made up entirely of pixels belonging to the skeleton of the object. Image enhancement algorithms offer the examiner different views of the print to aid in his decision to add or remove points of minutia. The 'Y' ascending overlay pinpoints exactly where SAFIS™ made the comparison in both prints for enhanced visual inspection.

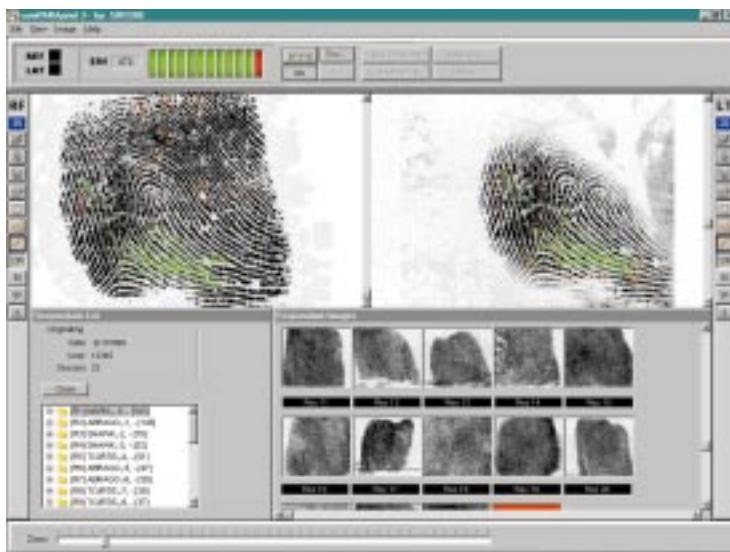

Screenshot from actual search sequence of latent fingerprint against the 10-print card database.

SAFIS™ System Leading Particulars:

- Latent and ten-print databases
- Virtually unlimited database size
- Acquire images via any TWAIN-compliant device capable of 600 dpi resolution. Convenient pre-sized capture boxed provided for use with your scanner input
- View prints side-by-side over a large range of magnifications.
- Automatically extract features such as ending ridges, islands and bifurcations
- Manually add or delete features
- Choose areas of the print to be ignored by the feature extraction and feature comparison engines
- Adjust image brightness, contrast and sharpness for best feature extraction
- View or print grayscale, binary, enhanced or skeletonized images of ridge structure
- Load and automatically compare latent and reference prints
- Automatically compare prints based on a region of the latent

SIRCHIE®'s ALIST™ Comparison Engine...

is able to rapidly compare prints, compensating for the distortions inherent in latent and rolled prints, and uncertainties in relative rotation to provide a graded measure of the similarity of the two prints. The comparison engine automatically makes a statistical comparison of the two prints, displaying a goodness rating for the comparison. In addition, a graphical overlay shows just what the comparison engine used as the basis of its decision, allowing intervention by the technician as desired. Comparisons can be made on the basis of the full latent, or on any user-defined portion of the latent against the ten-print database. To speed searches, search parameters—including hand and pattern type—can be set. In addition, searches can be made against the latent database to allow you to connect crimes. Searches can be stored for later recall.

SAFIS™ Search Methods:

- Latent to 10-Prints
- Latent to Latents
- 10-Print to Latents
- 10-Print to 10-Prints

Recommended Minimum Hardware Requirements:

- Windows 95+, NT 4.0+ Operating System
- 333 MHz Pentium Class Processor or better
- 128 Mb Ram
- Large Capacity Hard Drive
- Video Card Capable of at least 800 x 600 Screen Resolution at 16-bit color depth
- Color Monitor with 17" - 19" minimum Viewing Area
- Page Scanner with 600 dpi minimum

For complete information and specifications call or fax your request

CAT. NO. CCPARA8000L comPARAPrint™ II SAFIS™ SOFTWARE PACKAGE \$10,950.00

SCENESWEEPER™ ARGON LASER FEATURES

Portable

The SceneSweeper™ Argon Laser is the size of a small overnight case, it weighs 29 pounds and operates on standard 120 volt AC household power. This rugged compact design allows you to use the SceneSweeper™ Argon Laser wherever you need it.



Multiple Wavelengths

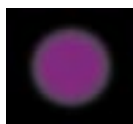

457 nm



488 nm



514 nm



<515 nm

Unlike other lasers, the SceneSweeper™ Argon Laser offers four different wavelength selections: 457 nanometers (long-wave ultraviolet), 488 nanometers (blue), 514 nanometers (green) and <515 nanometers (blue-green). This allows you to match the wavelength to the search type. Furthermore, it enables you to choose the wavelength that provides the greatest brightness for locating the sample and then switch to a wavelength that provides the brightest contrast for photographing the evidence.

Adjustable Intensity

The SceneSweeper™ Argon Laser provides better intensity control than any other light source. You can turn it down to as low as about 30 milliwatts which will enhance photographic detail by providing better contrast between the sample and the background or you can turn it up to about 400 milliwatts to sweep a scene and locate any and all fluorescing evidence.



20' Fiber Delivery

The SceneSweeper™ Argon Laser delivers its energy through a single 0.40 diameter glass fiber. Because the laser beam can be focused into a single fiber, unlike alternative light sources, its energy can be transmitted great distances without significant power losses. The SceneSweeper™ Argon Laser comes standard with a 20-foot long fiber for portability, however, custom-length fibers are available in any desired length. The fiber is protected by a Kevlar® sheath and a flexible stainless steel tube that is a mere 0.375 inches in diameter. The 20-foot fiber allows you to set the laser down in the middle of a room and process the entire room from end to end without having to move the laser. In the laboratory, you do not need to bring all of the evidence to one cluttered spot—you simply take the handpiece to the spot where you want to process the evidence.

Remote Control Handpiece

The remote control handpiece contains all of the laser controls and they are right at your fingertips. You can control laser operation, laser intensity and wavelength selection without having to go back to the laser. You can increase and/or decrease intensity of the laser and simultaneously change wavelengths without ever moving your eyes off of the evidence. There is no chance of losing evidence due to shifting your view. The remote control handpiece comes with a non-slip grip and ready to mount to a tripod when needed.

Beam Focusing

The remote control handpiece incorporates a set of zoom-type projection optics. At arms length from a wall you can have a light spot 3 feet in diameter to search for evidence and upon seeing potential evidence, with a twist of your wrist, you can focus the spot to 1-2 inches in diameter and focus all of the SceneSweeper™ Argon Laser's energy onto the suspected evidence. When you combine this feature with the adjustable intensity feature you have the ability to place exactly the right amount of energy on the sample to produce the greatest contrast for photography and evidence processing. Without these two powerful features, it is virtually impossible to get the best contrast. By controlling the intensity of the laser and light beam diameter, you have absolute control over how many watts per square centimeter strike the sample. Watts per square centimeter will determine sample brightness, contrast, and ease of sample retrieval.

Spot Diffuser

The spot diffuser softens the output light even more. Softening the light enables you to find trace evidence that absorbs light rather than fluoresces light, such as blood spatters. The diffuser also assists in camera focusing in certain situations.

Ballistics Attachment

The remote control handpiece produces a 1-inch diameter beam that can be used to trace ballistics over short distances (up to 75 feet) very quickly and conveniently. For longer range and more intricate ballistic traces the SceneSweeper™ Argon Laser comes ready to accept a ballistics attachment capable of tracing ballistics in excess of 1,000 yards. When the ballistics attachment is in place it generates a laser line onto a protractor that is printed on the front of the laser case. This allows you to set the vertical angle. A knob and protractor on the back of the attachment allow you to set the horizontal angle. By combining both of these protractors into the same unit you are able to set compound angles simply and very quickly. Additionally, the SceneSweeper™ Argon Laser puts out an amount of power that is 10 or more times powerful than anything on the market.



Fingerprints

The SceneSweeper™ Argon Laser is an exceptionally versatile fingerprint detection instrument. The variety of wavelengths produced by the SceneSweeper™ Argon Laser allows it to illuminate virtually all of the fluorescing powders and cyanoacrylate dyes.

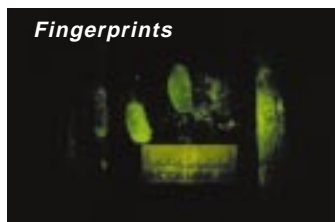

The SceneSweeper™ Argon Laser excels by providing you with the ability to control light intensity and beam size via the remote handpiece controls. By controlling both of these features across the various wavelengths available, you will be able to provide the optimum intensity to produce the greatest contrast. With the perfect contrast provided by the SceneSweeper™ Argon Laser intricate pore detail can often be obtained. The exceptional light control abilities and versatility of the SceneSweeper™ Argon Laser makes it the finest fingerprint instrument available.



Ballistics

Because the SceneSweeper™ Argon Laser produces a beam of coherent light it is a natural for ballistic tracing. Nothing else can fill this need and there are no other lasers in the forensic market that do the ballistics tracing job better, easier or faster than the SceneSweeper™ Argon Laser, simply the finest tool for ballistic tracing.

The remote control handpiece produces a one-inch diameter beam that can be used quickly and accurately to trace ballistics in short distance scenarios (up to 75 feet). For longer distances and intricate traces, the ballistics attachment will provide a one-millimeter beam that is visible in excess of 1,000 yards. The SceneSweeper™ Argon Laser comes standard with a level and tripod mount for quick ballistics setup. When the ballistic attachment is installed, compound angles can be 'dialed' in by way of its two protractors quickly and accurately. The SceneSweeper™ Argon Laser is clearly the finest ballistic tracing instrument available.



General Specifications

- Laser Type: Argon Ion—air cooled
- Laser Tube Type: Integral Mirror, Ceramic/Metal
- Laser Power: 400 mW
- Wavelength: 457 nm - 514 nm, adjustable
- Output Power Stability: +/- 5%
- Power Calibration: +/- 10% Internal
- Delivery System: Fused Silica Fiber Optic
- Power Control: 30-400 mW User selectable
- Laser Tube Warranty: 2000 hours

Electrical Specifications

- Uses any standard commercial wall outlet
- Voltage: 120 VAC
- Current: 20 AMP

Physical Specifications:

- Unit Dimensions: 16" L x 9" W x 11" H
- Laser Weight: 29 lbs.
- Shipping Weight: 34 lbs.



CATALOG NO. SSAL100 SCENESWEEPER™ ARGON LASER PRICE: \$12,995.00
CATALOG NO. SSAL100BA BALLISTICS ATTACHMENT PRICE: \$975.00
CATALOG NO. SSAL1001 AMBER GLASSES PRICE: \$20.00
CATALOG NO. SSAL1002 YELLOW GLASSES PRICE: \$31.00
CATALOG NO. SSAL1003 RED GLASSES PRICE: \$20.00
CATALOG NO. SSAL1004 AMBER SHIELD PRICE: \$13.00

MELLES GRIOT OMNIPRINT 1000A ALTERNATE LIGHT SOURCE

The Melles Griot Omniprint 1000A is a tunable wavelength source of light for forensic examination. The light is delivered by a six-foot fiber-optic cable at six user-selectable wavelength bands. There is a choice of four narrow band and two wideband output wavelengths each of which can be easily and rapidly selected with a rotary switch on the front panel. Indicator lights located on the front panel easily identify the wavelength band in use. The narrow band filters transmit at 450 nm, 485 nm, 525 nm, 570 nm. The two wideband wavelengths are white light and all wavelengths less than 530 nm. This wavelength selection affords the convenience of using established chemical processing techniques giving the user more diverse and discrete fluorescence capability and allowing rapid optimization of evidence contrast.

The Melles Griot Omniprint 1000A is powered by a commercially available state-of-the-art, 400-watt, high-intensity, blue enhanced metal vapor arc discharge lamp. The arc lamp lifetime exceeds 1500 hours—the longest lifetime available in a forensic light source. The light is supplied through a six-foot fiber-optic cable with an adjustable focus handpiece. The Melles Griot Omniprint 1000A weighs only 15 pounds and can be operated on either 115- or 220-volt standard household current for operation anywhere in the world.



Cyanoacrylate print dye-stained with ardox and viewed with the Melles Griot Omniprint 1000A

Leading features:

- Hands-free operation: unit can be mounted on a tripod for large area illumination
- Portability: Melles Griot Omniprint 1000A can be operated from an extension cord and/or portable generator
- Lightweight: 15 lbs
- Power requirements: Standard household current
- Housed in a rugged aircraft aluminum case

Unit consists of:

- Rugged aircraft aluminum case
- Control panel with detailed operating instructions
- Variable light output control
- Forced air cooled system
- 6 Output wavelength selections 570 nm, 530 nm, 525 nm, 485 nm, 450 nm as well as ultraviolet and infrared options
- White light
- Optional 10mm liquid light guide
- Rugged, flexible 6-foot fiber optic delivery cable, 10mm diameter or 6-foot liquid light guide
- Smooth exterior allows for decontamination
- 8-foot power cord
- Tri-pod ready mount
- User accessible fan filtration system for cleaner optics
- Fully interlocked quick change lamp mount
- 2 spare lamps
- 2 pair forensic examination goggles—amber
- 1-pair forensic examination goggles—red
- 1-pair forensic examination goggles—yellow

All Melles Griot Omnicrome products have a one-year warranty on parts and labor.

CATALOG # OMNI1000	OMNIPRINT 1000	PRICE: \$7,800.00
CATALOG # OMNIGD	OPTIONAL LIQUID LIGHT GUIDE	PRICE: \$1,000.00
CATALOG # OPBLUB	REPLACEMENT ARC LAMP	PRICE: \$350.00



PHOTO EVIDENCE MARKERS

SIRCHIE®'s photo evidence numbers and letters are now available in a plastic configuration. The markers are fabricated of 0.050" thick polystyrene material with a matte-finish to reduce reflection. Vinyl-clad aluminum markers can be found on page 172.

- CATALOG # PEN15V PLASTIC NUMBERS, 1 TO 15..... PRICE: \$31.50
- CATALOG # PEN1650V PLASTIC NUMBERS, 16 TO 50..... PRICE: \$64.50
- CATALOG # PEN5199V PLASTIC NUMBERS, 51 TO 99..... PRICE: \$91.50
- CATALOG # PEA26V PLASTIC EVIDENCE LETTERS, A THRU Z..... PRICE: \$51.50
- CATALOG # PDN17V PLASTIC INDICATOR SET/13..... PRICE: \$24.50

SEE PAGE 172 FOR FULL DESCRIPTIONS OF THE ABOVE

STERILE COTTON APPLICATOR SWABS AND SWAB BOXES

The Sterile Cotton Applicator Swabs are ideal for use in collection of trace liquid evidence—such as blood and other body fluids. Packaged two per sterile envelope. After the sample has been taken, it should be placed in a container for transportation to the lab. **SIRCHIE**® offers two types of swab boxes for your convenience—boxes preprinted with general information and plain boxes to allow agencies to mark directly on the box. The plain box has a pre-cut drying hole. Contact **SIRCHIE**® for other physiological containers not shown in this catalog.



- CATALOG NO. KCP160C COTTON-TIP APPLICATOR SWABS/100 PRICE: \$9.25
- CATALOG NO. KCP160M COTTON-TIP APPLICATOR SWABS/1000 PRICE: \$84.50
- CATALOG NO. CC1094C PRINTED SWAB BOXES/100 PRICE: \$19.95
- CATALOG NO. CC1094M PRINTED SWAB BOXES/1000 PRICE: \$179.50
- CATALOG NO. KCP196P PLAIN SWAB BOXES/100 PRICE: \$17.95
- CATALOG NO. KCP196M PLAIN SWAB BOXES/1000 PRICE: \$153.95

FLUORESCENT PHOTO SCALES

SIRCHIE®'s photo scales are now available in fluorescent orange or fluorescent green. These 6" rulers feature metric and English (inch) measurements. Pre-packaged in quantities of ten. Printed on .010 matte-finish vinyl.

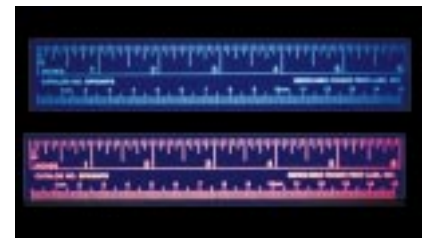
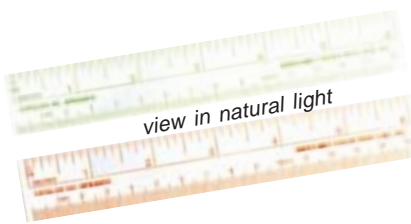

Fluorescent 245 to 520 nm

- CATALOG NO. EPS30FO ... ORANGE FLUORESCENT SCALES/10-PK. PRICE: \$4.95
- CATALOG NO. EPS30FG GREEN FLUORESCENT SCALES/10-PK. PRICE: \$4.95

FLASHLIGHTS FOR OBLIQUE LIGHTING

These **PRO-LIGHT**™ flashlights are ideal for use where oblique lighting of latent prints and dust prints are needed at the crime scene. The PL1000 is an inexpensive one-piece, clear-plastic auxiliary light that is small enough to store in a crime scene kit. The PL20P rechargeable flashlight will yield countless hours of service. It is great for searching large rooms for dust prints and at points of entry.



No. PL20P



No. PL1000

- CATALOG NO. PL1000 AUXILIARY FLASHLIGHT, 2-D CELLS (NOT INCLUDED) PRICE: \$10.95
- CATALOG NO. PL20P ... ABS THERMOPLASTIC RECHARGEABLE FLASHLIGHT PRICE: \$79.95

MIKROSIL™ CASTING MATERIAL

The Mikrosil™ casting material kit consists of two easy-to-use tubes, mixing pad and wooden spatula. The large tube contains the putty material and the smaller tube contains the catalyst. Mikrosil™ is available in brown, gray, black and white. Brown and gray are preferred by many tool mark examiners while white and black can be used to lift dusted latent fingerprints from rough or textured surfaces.



Mikrosil™ used to cast a door jam where a pry bar was used to gain entry.



Mikrosil™ used to lift latent prints from a textured vinyl surface.



- CATALOG NO. MCM100G MIKROSIL™ KIT, GRAY/7 OZ. (200g) PRICE: \$26.95
- CATALOG NO. MCM100B MIKROSIL™ KIT, BROWN/7 OZ. (200g) PRICE: \$26.95
- CATALOG NO. MCM100W MIKROSIL™ KIT, WHITE/7 OZ. (200g) PRICE: \$26.95
- CATALOG NO. MCM100BL MIKROSIL™ KIT, BLACK/7 OZ. (200g) PRICE: \$26.95
- CATALOG NO. MCM100CA CATALYST PRICE: \$5.95

SIRCH-VUE™ TAMPER INDICATOR TAPE

SIRCHIE®'s new SIRCH-VUE™ Tamper Indicator Tape is made of 1.25 mil thick polyester and is red with SIRCH-VUE™ imprinted in black ink. The tape is pre-wound on a three-inch core and is packaged in 180-ft. long rolls.

SIRCH-VUE™ tape can be easily applied to an evidence bag or box using standard hand-dispensing guns and is virtually impossible to remove without evidence of tampering. When applied to items, the tape creates a bond that will reveal the word "violated" upon tampering. Once the hidden message is revealed it is extremely difficult to reassemble without detection.



Apply Sirch-Vue™ to packages that require security.



Package that has been sealed with SirchVue™.



The word "violated" is revealed after tape has been tampered with.

- CATALOG # SVUE100 SIRCHVUE™ TAMPERPROOF TAPE, 2" X 180' PRICE: \$32.50
- CATALOG # SVUE1001 SIRCHVUE™TAPE DISPENSER PRICE: \$7.50

AMERICAN INSTITUTE OF APPLIED SCIENCE



Founded in 1916, The American Institute of Applied Science is recognized worldwide for its comprehensive training of professionals in the field of forensic identification and investigation. Headquartered in Youngsville, North Carolina, the American Institute of Applied Science offers a home-study program that is the best of its kind.

Law enforcement agencies throughout the world either accept or require this program for positions in identification and investigation departments. Graduates are eligible for the following six hours of college credit through Burlington County College in Pemberton, New Jersey:

- **CRJ113 Criminal Investigation. The fundamentals of criminal investigation, theory and history are surveyed.**
- **CRJ114 Criminalistics. The collection, identification, preservation and transportation of physical evidence is studied.**

Graduation from AIAS courses satisfies the educational requirements for certification as a crime scene technician by the **International Association for Identification (IAI)**.

The American Institute of Applied Science's forensic science course consists of studies in the following:

101 BASIC PROGRAM

- Fingerprint Classification and Identification, 26 lessons
- Modus Operandi, 3 lessons
- Criminal Investigation, 10 lessons
- Firearms Identification, 10 lessons
- Questioned Document Examination, 8 lessons
- Police Photography, 10 lessons

201 ADVANCED PROGRAM

- Fundamentals of Forensic Investigation, 5 lessons
- Trace Evidence and its Significance, 4 lessons
- Fundamentals of Arson and Explosives Investigation, 4 lessons
- Significance of Blood in Criminal Investigations, 3 lessons
- Forensic Investigations into Drugs and Alcohol, 5 lessons
- Document and Voice Examination, 1 lesson
- Firearms, Toolmarks and Footwear Impressions, 3 lessons
- Investigating Forensic Science on the Internet, 1 lesson

For more information about the school, contact:

The American Institute of Applied Science

Call: (800) 354-5134, (919) 554-2500

Fax: (919) 556-6784

or write: 100D Hunter Place, Youngsville, NC 27596

CRIME SCENE TECHNOLOGY ACCELERATED TRAINING COURSE



Emphasis is placed on providing students with hands-on experience.

Thoroughly trained investigators are the key to successful evidence collection. Recognizing the need for accelerated training in crime scene investigation, **SIRCHIE®** Finger Print Laboratories offers a specialized, intensive, 40-hour course—**Crime Scene Technology**. More than 5,000 investigators have graduated from this program. The course covers the scientific methods of collection, identification, evaluation and preservation of physical evidence. The program is centered on the actual use of equipment and materials necessary for a thorough and comprehensive evidence collection mission. Emphasis is placed on providing each student with hands-on experience, with lecture time held to a minimum.

Subjects covered :

- Securing the crime scene
- Fingerprint theory; fingerprint taking; powder development; chemical and fuming development; photographing and lifting
- Fire and footwear evidence
- Casting techniques
- Tool mark and impression evidence
- Physiological fluid identification
- DNA and rape evidence collection
- Serial number restoration
- Narcotics, drug and abused substances screening
- Mock crime scene examination

For more information about Crime Scene Technology Courses, contact:

SIRCHIE® Finger Print Laboratories, Inc.

Attn: Director of Training

Call: (800) 356-7311, (919) 554-2244

Fax: (800) 899-8181

or write: P.O. Box 639, Youngsville, NC 27596

Index

- A**
Accelerator Lamp, Silver Nitrate 74
Accelerator, Serial No. Restoration 262
Accident/Crime Scene
 Evidence Markers 172-175
 Sketch Kits 178-179
 Templates 180-181
Adapter, 1:1, 35mm 151
Adhesive Side Powder 81, 104
Advance Response Kit 118A
ALIS Automated Latent Identification System 328-330
All Purpose Police Field Kit 111
Alternate Light Source, Omniprint 334
Alternate Light Sources 120-129, 338-341
American Institute of Applied Science, Training 337
Amido Black 81
Anti Odor Masks 200-201B
Anti-Putrefaction Masks 200-201B
Applicators
 Brushes, Latent Print 59-63
 FACII® Powder/Brush Delivery System 63
 Magnetic Powder 68, 69
Apprehender Special Kit 250
Ardrox Print Enhancer (Spray and Liquid) 82
Argon Laser, Scenesweeper 332, 333
Arson Investigation 208-211
Atomic Absorption Analysis Kit 257
Automated Fingerprint Identification System 331
Automated Latent Identification System 328-330
Autopalm Printing Outfits 30-35
- B**
Backing Cards, Fingerprint 100-101
Bag
 Body 186
 Evidence 183-189
 Sealers 187
Barrier Tape 177
Basic Yellow Reagent 81-82
Biohazard
 Cleanup Kit 199
 Labels 199
 Protective Clothing 199-200
 Test Kits 211A-211D
Black Lights 234-242
Blank Fingerprint Guide Cards 49
Blood Alcohol Collection Kit 230
Blood Alcohol/Urine Specimen Collection Kit 230
Blood Test Reagents, Dischaps 265
BLUEMAXX™
 Accessories 129
 Forensic Light System 120-129
 Latent Specialist Kit 127
 Master Fuming & Evidence Locating Kit 127
 Patrol Kit 127
Body Bags 186
Bomb Response Vehicle 297
Boxes, Evidence 190
Brushes, Latent Print
 Camel Hair 62
 Carbon Filament 61
 FACII® 63
 Feather Duster 61
 Fiberglas 59
 Fiberglas Sweeper 60
 Fingerprint Powder 59-63
 Retractable Fiberglas® 60
Bullet Evidence Bags 186
Bulk Powder Containers 58
Burglary Fingerprint Kit, Military Spec 118
Burglary Squad Kit 112
Butane Fuel 77
- C**
Cabinets
 Fingerprint Filing 48-49
 Forensic Evidence Drying 274-275
 Fuming 83-89, 276-280
Cadaver Fingerprint Taking Kit 43
Camel Hair Brushes 62
Cameras
 Carrying Cases 149
 Evidence 144-147
 Fingerprint, Video FVC100 326-327
 Mug Shot 153-155
 Periscope 303
 Photo ID 153-155
Cans, Evidence Collection 191, 209
Carbon Filament Brush 61
Card Holders 16-19
Cards, Lifted Print Backing 100-101
Cards, Record
 Children 47
 Criminal 45
 Major Case 46
 Palm 47
 Personal 47
 Postmortem 46
Cases, EV-CAM Carrying 149
Casting
 Frames 215
 Kits 214-216, 219
 Material, Mikrosil 336
 Materials 213-221
 Putty, Durocast 220
Chambers
 Cyanoacrylate Fuming 84, 85
 DFO Development 87
 Heat 83
 Vacuum, Cyanoacrylate 88-89
Chart, Fingerprint Wall 49A
Chemical Enhancement Reagents 81
Chemicals, Latent Development 72-82
China Marker 198
Child Fingerprint Record Card 47
Chromatography of Marijuana, Thin-Layer 267
Civil Defense Set 211A
Clandestine Lab Investigation Kit 211C
Classification Discs 131-135
Cleaners
 Cyanoacrylate 79
 Hand 20-21
 Powder Foam-Away 104
 Slab & Roller 22
Climate Control for Surveillance Vehicles 306
Clue Spray™ Detection Powder 245
Coin Box/Galvanic Latent Print Powder 56, 58
Compact Manual Periscope 304
Comparators,
 Automated Fingerprint ID Systems 326-331
 Illuminated Fingerprint 136
 Forensic Optical 138-142
ComPHOTOfit® Facial Identification Software .. 285-287
Composites, Facial
 Foil System 288
 Computer Software 285-287
Computer Latent Identification Systems 328-331
Copper Metallic Latent Print Powder 55, 58
Containers, Evidence 191
Cotton Applicator Swabs, Sterile 335
Crayons, Fluorescent Invisible 247
Crime Scene
 Latent Print Kit 115
 Markers 172-175
 Security Signs 177
 Sketch Kits 178-179
 Training 337
 Templates 180-181
Crime/Traffic Scene CAD Software 289
Criminal Fingerprint Record Card 45
Crystal Ampoules
 Iodine 71
 Silver Nitrate 74
Crystal Violet Reagent 81
Crystals, Ninhydrin 73
Cyanoacrylate
 Cleaning Compound 79
 Dispersal Pads 79
 Fuming Chambers 84-89
 Fuming Enclosure 281
 Liquid 79
 Products 76-79
 Fuming Packets, FINDER™ 78
Cyanowand 77
- D**
Debris Sifting Shovel 208
Dental Stone Casting 218
Detection Kits, Visible Stain 253-254
Detection Materials, Thief
 Fluorescent Invisible 244-248
 Visible 251-252
Detective Pocket Latent Print Kit 102
Detectors
 Gas and Vapor 211A-211D
 Hydrocarbon 211
 Metal 283-283B
Developer
 Crystal Violet 81
 DFO 75, 81
 FINDER™ Latent Print Packets 78
 Iodettes 71
 Ninhydrin Crystals 73
 Physical 82
 Rhodamine 6G 81
 Silver Latent Print Spray 74
 Silver Nitrate 74
Development Chamber, DFO 87
Development, Latent Fingerprint 50-89
DFO (1,8 Diazafuoren-9-ONE)
 Development Chamber 87
 Powder 75
 Reagent Powder 81
 Spray 76
Digital Mug Shot Sign 158
Dischaps™
 Blood Test Reagents 265
 Fluorescent Invisible Marking Ink 248
 Seminal Fluid 263
 Serial Number Restoration Liquid 261
Discs, Classification 131-135
Disinfecting Spray 281
Dispensers, Tape 95
Dispersal Pads, Cyanoacrylate 79
Disposable
 Fuming Chamber 84
 Iodine Fuming, Fumette 70
 Jumpsuit/Shoe Covers 200
DNA Evidence Collection Kit 229
Document Analysis 268-271
Document Examination Plates 268
Drawing Library (CAD-based) 289
Drug Testing Materials 266-267B
Dual Wave Positive Detection Kit 250
Durocast Casting Putty 220
Dust & Dirt Hardener 215
Dye Liquid Enhancer 82
Dye Spray, After Fuming Fluorescent 82
- E**
Education
 American Institute of Applied Science 337
 Crime Scene Technology Training 337
 Video, How to Take Fingerprints 49B
Electronic Digital Mug Sign 158
Electrostatic Print Lifting Kit 222
Elimination Fingerprint Outfit 38
Enhancement Reagents 81-82
Enhancer, Iodine Print 71
Envelopes, Evidence 188
Erased Writing Detection Kit 269
EV-CAM III Evidence Camera 145
Evidence Collection Kits
 Arson 210
 DNA 229
 Identification 206
 Roll-Up 207
 Sexual Assault 226
 Technician Kit 118B
 Vacuum 202-205
Evidence Collection and Processing
 Arson Equipment 208-211
 Bag Sealers 187
 Bags 183-189
 Boxes 190
 Camera, Video, FVC100 326, 327
 Cameras 144-147

Cans	191, 209	Detection Materials	244-248	Postmortem Tool	40
Containers	191	Marking Pen	247	Rollers	14-15
Detection, Alternate Light Sources	121-124, 334	Skin Marking Kit	248	Fluorescent Invisible	247
Drying Cabinets	274-275	Snare Kit	249	Slabs	15, 19
Envelopes	188	Tagging Ink and Pen	248	Inkless Fingerprint Pads	49A
Impression Casting and Lifting	213-222	Tagging Kit	249	Instruction, Fingerprint	49B
Jars	191	Writing Ink	247	Investigator's Field Blood Test Kit	265
Labels	195-197	Foam-Away, Powder Cleaner	104	Investigator's Mapping Kit	173
Markers	198	Footprint		Invisible Detection Materials	244-248
Rules, Photo	169	Casting Kit	219	Invisible Latent Detection Instrument, RUVIS	308-318
Scales, Photo	168-171	Lifters	99, 218	Iodine	
Scraper/Scraper	198	Residue Lifters	218	Iodettes	71
Scrapers	198	Footwear & Tire Tread Print-Out System	221	Fuming	70-71
Tape		Forensic		Kit, Fuming	105
Dispenser	191B	Comparators	138-141	Print Enhancer	71
Marking	194	Evidence Collection Kits	224-230	J	
Photo Rule	169	Evidence Drying Cabinets	274-275	Jars, Evidence Collection	191
Repulpable	205	Fluorescence Light Kits	322-325	Jumpsuit/Shoe Covers, Disposable	200
Sealing	191A-195	Light System, BLUEMAXX™	120-129	K	
Ties	190	Light Systems	120-129, 338-341	Kits	
Tubes	191	Macro Video Systems	320-321	Adhesive-Side Powder	102
Vacuum Filter	204	Photography Kit	148	Advanced Response	118A
Vehicles	292-295	Photography, BLUEMAXX™ Kit	125	All-Purpose Police Field	111
Explosives Residue Test Kit	259	Ultraviolet Lights	234-242	Apprehender Special	250
F		Video Recording System	326-327	Arson Investigation	209-210
FAC II® Powder/Brush Delivery System	63-64	Workstations	276-280	Atomic Absorption Analysis	257-258
Face Shield (Ultraviolet)	242	Frames, Casting	215	Biohazard Cleanup	199
Facial Identification		Fraudulent Check Bags	186	Biohazard Test	211A-211D
Foil Kit	288	Fuel, Butane	77	Blood Alcohol Collection	230
Software	285-287	Fumette Disposable Iodine Fuming	70	Blood Alcohol/Urine Specimen Collection	230
Feather Duster Brush	61	Fuming		BLUEMAXX Latent Print Specialist	127
Fiberglas Latent Print Brushes	59-60, 63	Cabinets	276-280	BLUEMAXX Master Fuming & Evidence	128
Field & Lab		Chambers	83-89	BLUEMAXX Patrol	127
Disaster Kit	44	Kit, Iodine	105	Burglary Squad	112
Restoration Accelerator	262	Cyanoacrylate	76-79	Burglary, Fingerprint	118
Field Kits, Latent Print	102-118	Iodine	70-71	Crime Scene Latent	115
File Cabinets, Fingerprint	48, 49	Trays, Disposable	79	Detective Pocket Latent	102
Film		G		DNA Evidence Collection	229
Holders	150	Gas and Vapor Detection	211A-211D	Drug Testing	266-267B
Polaroid	150	Gloves		Dual Wave Positive Detection	250
Filter, Evidence Vacuum	202	Cotton, White	199	Electrostatic Print Lifting	222
FINDER™, Cyanoacrylate Packets	78	Latex	200, 254	Erased Writing Detection	269
Finder III Latent Print Kit	107	Nitrile	200	Evidence Collection	206-207
Fingerprint		Goggles (Ultraviolet)	242	Evidence Technician I	118B
Brush/Powder Combination, FACII®	63	Guide Cards, Blank	49	Explosives Residue	259
Backing Cards	100-101	Gunshot Residue Materials	257-260	Facial Identification	288
Camera, Video	326-327	H		Field & Lab Disaster	44
Cameras	144-147	Hand Cleaner Towelettes	20	Finder III Latent Print	107
Cards, Record	45-47	Hand Cleaners	20-21	Fluorescent Invisible Skin Marking	248
Chart, Wall	49A	Hand-Held Metal Detectors	283-283A	Fluorescent Invisible Snare	249
Comparators	138-142	Handwriting Analysis Instrument Kit	269	Fluorescent Invisible Tagging	249
Development Products	50-89	Hardcore Blue Dental Stone Casting	218	Forensic Evidence Photography	148
File Cabinets, Fingerprint	48-49	Hardcore Tire & Footprint Casting Kits	219	Forensic Fluorescence Light Kit	322-324
Guide Cards	49	Hardener, Dust & Dirt	215	Forensic Photography, BLUEMAXX	125
Ink, Tube	13	Heat Chambers	83, 85, 87	Handwriting Analysis	269
Instruction	49B	Heat Seal Evidence Bags	185-187	Hospital Sex Crimes	228
Kits, Latent	102-118	Heat Sealers	187	Hunter Latent Print	106
Lifting Products	90-101	Heavy Volcano Latent Print Powder	55	Indented Writing Restoration	268
Magnifiers	131-137	Hi-Fi Volcano Latent Print Powder	55-56	Investigator's Blood Test	265
Pads	6, 7, 49A	Hinge Lifter		Iodine Fuming	105
Powder		Fingerprint	90-91	Latent Blood Print Detection Kit	264
Fluorescent	57	Write-On Tab	98	Latent Print	102-118
Latent	55-58	Holders		Latent Print Finder	114
Magnetic	65-67	Card	16-19	Latent Print Search	107
Powder Brushes	59-63	Postmortem Record Strip	40-41	Latent Print Specialist	116
Record Cards	45-47	Hospital Sex Crimes Kit	228	Liquid Rubber Lifter	97
Tape		Humidifier Kit	86	Magnetic Latent	104
Dispensers	95	Hunter Latent Print Kit	106	Magnetic Powder	69
Lifting	94-95	Hydrocarbon Detector	211	Master Expert Latent Print Kit	108
Fingerprint Taking		I		Master Field & Lab Blood Test Kit	264
Kits, Porelon	36-39	Identification		Master Firearms Detection	260
Outfits	23-26	Camera Systems	156, 163-165	Master Latent Print Inv.	117
Pedestal Units	27-29	Cameras	153-155	Master Number Restoration	262
Postmortem	42-44	Height Screen	167	Master Pocket Latent Print	109
Fingerprint Video, Instructional	49A	Signs, Photographic	158-162	Master Questioned Document	271
Finger Straighteners, Post Mortem	41	System, Automated Latent, ALIS	328-330	Master Seminal Fluid Testing	263
Firearm Discharge Residue Collection	257-260	System, Search Automated, SAFIS	331	Military Spec.	118
Flashlights, Pro-Light	335	Impression Evidence Collection	213-222	Multi-Process Latent Print	109
Fluorescence Light Kits, Forensic	322-325	Indented Writing Restoration Kit	268	NARK® Field Testing of Drugs & Narcotics	266
Fluorescent		Infrared Viewer, Micron Series	270	NARK® II Narcotics Analysis	267A-267B
Dye Spray	82	Ink		Patrol Car Detection	249
Fingerprint Powder	57, 64, 67	Cleaners	20-22	Patrol Latent	102
Photo Scales	335	Disposable Strips	12	Personal Protection	199
Fluorescent Invisible		Fingerprint (Tube and Spray)	13	Polaroid Spectra	151
Crayons	247	Pads	6-7	Postmortem	42-44
Dischaps	248			Portable Police Laboratory	272

Professional Latent Print	106
Prosecutor's Suspect Evidence	228
Reflective UV Imaging, RUVIS	308-318
Restor-A-Gel Restoration	261
Sex Crimes Evidence Collection	224-229
Scanning Electron Microscopy	258
Scott Latent Print	103
Search II Latent Print Kit	110
Signal Fingerprint Inv.	113
Silicone Casting	214
Small Particle Reagent	105
Suspect, Sexual Assault	227
Technician Latent	103
Tire & Footprint Casting	216
Trace Metal Detection	259
Type II Burglary Fingerprint ID	118
Type III Postmortem Fingerprint ID Kit	118
Knife, Retractable Lifter	97
KRIMESITE SCOPE	308-318
L	
Labels	
Biohazard	199
Evidence	196-197
Lansberry's Ridge Builder	13
Laser, Argon, Scenesweeper	332-333
Latent Blood Print Detection Kit	264
Latent Identification Systems, Automated	328-331
Latent Print	
Backing Cards	100-101
Chemicals	72-82
Detection, RUVIS	308-318
Development Products	50-89
Powder Brushes	59-63
Powder, Magnetic	65
Powders	55-58
Latent Print Kits	
Crime Scene	115
Detective Pocket Latent	102
Finder	114
Finder III	107
Hunter	106
Master	117
Master Expert	108
Master Pocket	109
Multi-Process	109
Patrol	102
Scott	103
Search II	110
Search Kit	107
Specialist Kit	116
Specialist Kit, BLUEMAXX	127
Technician	103
Lateral Drawer Filing Cabinets	48-49
Latex Gloves	200, 254
Lens Adapter, 1:1, 35mm	151
Letter Bomb Detector	283B
Leuco-Malachite Dischaps	265
Lifted Print Backing Cards	100-101
Lifters	
Fingerprint Hinge	91, 98
Footprint	99, 218
Lift-O-Tabs™	92-93
Liquid Rubber Kit	97
Palm/Cluster	96, 97
Peel & Lift Tape	99
Rubber Fingerprint	96
Rubber Footprint	99
Lifting Products, Fingerprint	90-101
Lifting Tape Dispensers	95
Lifting Tapes	94-95
Lift-O-Tabs	92, 93
Light System, BLUEMAXX Forensic	120-129
Limited Wavelength Detection Powder	245
Lights, Ultraviolet	234-242
Liquid Rubber Lifter Kit	97
Liquid Silicone Rubber	213
Longwave UV Lights	235-238, 241-242
Luminol Invisible Blood Reagent	265
M	
Macrography Photography Scales	170
Magnet, Permanent Recovery	208
Magnetic	
Latent Print Kit	69, 104
Powder Applicators	68-69
Powders	65-67
Sweeper Kit	104
Wands	68-69
Magnifiers, Fingerprint	131-137
Major Case Record Cards	46
Mapping Kit, Investigator's	173
Marabou Feather Duster	61
Markers, Evidence	198
Masks, Anti-Odor, Anti-Putrefaction	200-201B
Master Kits	
Expert Latent Print	108
Field & Lab Blood Test	264
Firearms Detection	260
Latent Print Investigation	117
Number Restoration	262
Pocket Latent Print	109
Questioned Document	271
Seminal Fluid Test	263
Metal Detection Sweeper	208
Metal Detectors	283-283B
Metallic Latent Print Powder	55, 58
Mikrosil™ Casting Material	336
Military Spec. Kits	118
Mixing Bowls	216
Mobile Command Post	296
Mobile Police Station	291
Mug Shot Cameras	153-155
Mug Shot Signs	158-162
Multi-Process Latent Print Kit	109
N	
Narcotics Testing Materials	266-267B
NARK® Field Testing of Drugs & Narcotics Kit	266
NARK® II Narcotics Analysis Kit	267A-267B
NARK® Replacement Tests	267
Ninhydrin	
Crystals	73
Fixative	73
Special Formula	73
Spray	72-73
Nitrile Gloves	200
O	
Omega-Print Cyanoacrylate Products	79
Omega-Print Dispersal Pads	79
Omniprint Alternate Light Source	334
Optical Comparators	138-142
Optical Enhancement Products	131-142
Overview of Chemical Tools	52-53
P	
Pads	
Dispersal, Cyanoacrylate	79
Fingerprint	
Ceramic	49A
Porelon	6-7
Stainfree™	6-7
Palm Print	
Lifters	97
Record Cards	45
Palm Print Taking Equipment	30-35
Paste	
Invisible Detection	246
Visible Detection	252
Patrol Car Detection Kit	249
Patrol Latent Print Kit	102
Pedestal	
Fingerprint Taking Units	27-29
Palm Printing Outfits	34-35
Peel & Lift Tape Pads	99
Periscope	
Cameras	303
Compact Manual	304
Remote Control	303
System	302
Surveillance	302
Permanent Recovery Magnet	208
Personal Protection Kit	199
Photo Documentation Kits	174-175, 335
Photo Evidence	
Adapter, 1:1, 35mm	151
Alphabet	172
Direction Indicators	172
Identifier Booklets	173
Labels	169
Locator Cones	172
Markers	172-175
Rulers	149, 169
Rules	149, 335
Scale, Folding	170
Scales	168-171
Scales, Fluorescent	335
Photo Files	166-167
Photo Identification	
Cameras	153-155
Sign	157-162
Sign Replacement Numbers & Letters	162
Stands	156-157
Systems	163-165
Photography Kit, Forensic	148
Physical Developer	82
Physiological Fluid Testing Materials	263-265
Plaster Casting	215-218
Plastic Backing Sheets, Vinyl	100
Plastic, Serial No. Restoration	262
Polaroid	
Film	150
Sheet Film Holder	149
Spectra Law Enforcement Kit	151
Porelon Fingerprint Taking Kits	36-39
Porelon®	
Pads	6-7
Palm Printing Equipment	30-35
Pedestal Fingerprint Taking Units	27
Postmortem Inking Tool	40
PrintMatic Roller	8-12
Portable	
Fingerprint Taking Outfits	26
Fuming Chamber	84
Humidifier	86
Police Laboratory Kit	272
Surveillance System	304
Postmortem	
Fingerprint ID Kit, Type III	118
Fingerprint Kits	42-44
Holders	40-41
Inking Tools	40-41
Pre-Inked PrintMatic™ Roller	11
Record Strips	46
Powder	
Adhesive-Side	81
DFO	75
Dual Purpose	56, 58
FAC II®	64
Fluorescent	57, 67
Magnetic	65-67
Metallic	55, 58
Powder Applicators	59-63, 68-69
Primer Residue, Atomic Absorption Analysis Kit	257
PrintMatic™ Porelon Roller	8-12
Printover™ Tabs	47
Prisoner Transport Vehicle	298-299
Professional Latent Print Kit	106
Pro-Light™ Flashlights	335
Prosecutor's Suspect Evidence Kit	228
Protective Clothing Outfits	200
Putty, Casting	220
Q	
Questioned Document Evidence Bag	186
Questioned Document Materials	268-271
Quick Guide to Surfaces	54
R	
Reagents	
Basic Yellow	81
Crystal Violet	81
DFO	75, 81
Enhancement	81
Iodine Fuming	70-71
Ninhydrin	72-73
Silver Nitrate	74
Small Particle	80
Record Card Holders	16-19
Record Cards	
Children	47
Criminal	45
Major Case	46
Palm	45
Personal	47
Postmortem	46
Record Strips, Postmortem	46
Reflective UV Imaging, RUVIS	308-318
Rejuvenator Cleaner	99
Replacement Filters, Forensic Workstations	281
Replacement Powders, FAC II	64
Repulpable Evidence Tape	205
Respirator, Particulate	201A

Restor-A-Gel Number Restoration Kit	261	Slab & Roller Cleaners	22	Tire & Footprint Casting Kit	216, 219
Restoration Accelerator	262	Slabs, Inking	15	Tire Tread & Footwear Print-Out Collection	221
Retractable Brushes	60	Small Particle Reagent	80	Torchlite, UV Light	242
Retractable Lifter Knife	97	Small Particle Reagent Kit	105	Towelettes, Hand Cleaner	20
Rhodamine 6G Reagent	81	Snow Print Wax	216	Trace Metal Detection Kit	259
Ridge Builder, Lansberry's	13	Software, Crime & Accident Scene CAD	289	Training, Fingerprint Taking Video	49A
Ridge Counter	198	Software, Facial Identification	285-287	Training Programs	
Rogues Gallery, Visible Files	166-167	Special Purpose Vehicles	290-307	American Institute of Applied Science	337
Rollers, Ink	14-15	Specialist Kit, Latent Print	116	Crime Scene Technology	337
Rollers, Porelon PrintMatic	8-11	Specimen Collection Kit	230	Trays, Omega-Print™ Disposable Fuming	79
Rotary Slab & CardHolder	19	Spectacles, Ultraviolet	242	Tubes, Evidence Collection	191
Rubber Lifter Rejuvenator	99	Spectra, Law Enforcement, Polaroid Camera	151	Tubing, Evidence Bag	189
Rubber Lifters		Spoon, Postmortem	40-41	Type II Burglary Fingerprint ID Kit	118
Fingerprint/Palm Print	96	Sport Utility Video System	305	Type III Postmortem Fingerprint ID Kit	118
Footprint	218	Spray		Tyvek® Evidence Bag	188
RUVIS, Reflective UV Imaging	308-318	Ardrox	82	U	
S		Basic Yellow	82	Ultraviolet	
SAFIS™ SEARCH ® Automated Fingerprint		DFO	75	Face Shield	242
Identification System	331	Ninhydrin	72-73	Imaging System, RUVIS	308-318
Scales, Photo Evidence	168-171, 335	Silver Latent Print	74	Goggles	242
Scanning Electron Microscopy Primer Residue Kit ..	258	Silver Nitrate	74	Lights	234-242
Scenesweeper Argon Laser	332-333	Small Particle Reagent	80	Spectacles	242
Scott Latent Print Kit	103	Stainless Fingerprint Ink Pads	49A	Torchlite	242
Scribers	198	Stands, Photo ID	156-157	Urine/Blood Alcohol Collection Kit	230
Sealer, Evidence Bag	187	Sterile Cotton Applicator Swabs	335	V	
Sealing Tape, Evidence	191A-195	Superglue	76-79	Vacuum Chambers,	88-89
Seals, Evidence	195, 197	Superglue Fuming Enclosure	281	Vacuum Sweeper, Evidence	202-205
SEARCH ® Automated Fingerprint Identification		Surveillance		Vehicles	
System, SAFIS™	331	Periscope	302	Bomb Response	297
SEARCH ® II Latent Print Kit	110	System, Portable	304	Evidence Collection	292-295
SearchAlert™ Hand-Held Metal Detector	283	Systems & Equipment	300-307	Mobile Command Post	296
SearchBaton™ Hand-Held Metal Detector	283A	Vehicles	300-301	Mobile Police Station	291
Security Signs, Crime Scene	177	Suspect Evidence Kit, Prosecutor's	228	Prisoner Transport	298-299
Seminal Fluid Testing Dischaps	263	Sweeper		Special Purpose	290-307
Serial Number Restoration		Brush, Fiberglass	60	Sport Utility Video System	305
Accelerator, Field and Lab	262	Magnetic Latent Print Kit	104	Surveillance	300-301
Liquid, Dischaps™	261	Wand, Magnetic	69	Video	
Plastic	262	Syringe Transport Tubes	191	Fingerprint Camera FVC100	326-327
Sex Crimes Evidence Collection Kits	224-229	T		Monitor & Recording System	305
Sexual Assault		Tabs		Recording System, Forensic	326-327
Evidence Collection Kits	226	Printover™	47	Forensic Macro Systems, FX4 and FX7	319-321
Suspect Kits	227	Sirch-Lift™	93	Training, How to Take Fingerprints	49A
Sheet Film Holder	149	Tags, Evidence	196-197	VISA Voting Integrity Systems	255
Shoe Covers	200	Tamper Indicator Tape, Sirch-Vue™	336	Visible Filing System, Rogues Gallery	166-167
Short-wave UV Lights	238-241	Tape		Visible Stain Detection	
Shovel, Debris Sifting	208	Barrier	177	Kits	253-254
Signs		Evidence Marking	194	Materials	251-252
Crime Scene Security	177	Evidence Sealing	191A-192	Voting Integrity Systems, VISA	255
Photo ID	157-162	Fingerprint Lifting	94-95	W	
Signat Fingerprint Investigation Kit	113	Photo	169, 171	Wall Chart, Fingerprint	49A
Silicone Casting		Repulpable Evidence	205	Wand, Cyanoacrylate (CYANOWAND™)	76-77
Kits	214, 219	Tamper Indicator, Sirch-Vue™	336	Wands, Magnetic Applicator	68-69
Material	213	Tape Dispenser, Evidence	191B	White Cotton Gloves	199
Silver Nitrate		Tape Dispensers	95	Write-Block Evidence Bags	189
Accelerator Lamp	74	Tape Measure	181	Wonda-Wand Magnetic Applicator	69
Crystal Ampoules	74	Technician Latent Print Kit	103	Write-On Hinge Lifter	98
Spray	74	Templates, Crime/Accident Scene	180-181	Z	
Silver Latent Print Spray	74	Thief Detection Materials	244-254	ZIP-MIX Plaster Casting	215
Sirch-Lift Tabs	93	Thin Layer Chromatography of Marijuana	267	Zip-Top Evidence Bags	187
Sirch-Vue Tamper Indicator Tape	336	Three-Day Transparent Detection Fluid	252		
Sketch Kits, Crime/Accident Scene	178-179	Ties, Evidence	190		
Slab/Cardholder Combinations	19	Tiger UV Ultraviolet Light	234		

SIRCHIE®

Finger Print Laboratories, Inc.

100 Hunter Place • Youngsville, North Carolina 27596 USA

PHONE:

TOLL FREE : (800) 356-7311

INTERNATIONAL: (919) 554-2244

FAX:

TOLL FREE : (800) 899-8181

INTERNATIONAL: (919) 554-2266

INTERNET:

E-MAIL: sirchie@mindspring.com

WEB: <http://www.sirchie.com>

ORDER FORM by FAX, MAIL or EMAIL

To Fill out electronically: Click on gray box and type in information—then hit [TAB] key for next box.

SOLD TO	Name/Dept.:	_____		
	Address:	_____		
	City	State	Zip	
	Phone	_____		



SHIP TO	Name/Dept.:	_____		
	Address:	_____		
	City	State	Zip	
	Phone	_____		

SHIPPING AND HANDLING within Continental U.S.	
Subtotal	Shipping Charge
\$25.00 - \$50.00	\$8.00
\$50.00 - \$150.00	\$11.00
\$150.00 - \$300.00	\$15.00
\$300.00 - \$500.00	\$17.00
\$500 and over	CALL

QUANTITY	CATALOG #	DESCRIPTION	UNIT PRICE	TOTAL PRICE

MINIMUM ORDER: \$25.00 PLEASE CHECK SUBTOTAL

Check One:

Card #: _____

Exp. Date: _____

Cardholder's Name: _____

Signature: _____

SIRCHIE®
 FINGER PRINT LABORATORIES, INC.
 100 Hunter Place, Youngsville, NC 27596
 Phone: (800) 356-7311 or (919) 554-2244
 Fax: (800) 899-8181 or (919) 554-2266

SUB-TOTAL	
SALES TAX (NC and NJ add 6%)	
SHIPPING	
GRAND TOTAL	



Visit our website at
<http://www.sirchie.com>.

ORDER BY PHONE:
 TOLL FREE: 800-356-7311
 INT'L 919-554-2244

**FAX LINES OPEN
 24-HOURS
 (800) 899-8181**

**BUSINESS HOURS:
 8:00 AM - 5:30 PM
 MONDAY - FRIDAY**

• Open account billing extended to government agencies